

Surface Mount

Monolithic Amplifier

LEE2-6+

50Ω DC to 7 GHz



2mm x 2mm

The Big Deal

- Low Noise figure, 2.3 dB at 2 GHz
- Low Current, 16 mA
- Broadband matched

Product Overview

LEE2-6+ (RoHS compliant) is wideband current driven amplifier fabricated using HBT technology. In addition, the LEE2-6+, has good input and output return loss over a broad frequency range without the need for external matching components. Lead finish is Tin Silver over Nickel. It has repeatable performance from lot to lot and is enclosed in a 2mm x 2mm x 0.89mm 6-lead MCLP package for very good electrical performance.

Key Features

Feature	Advantages
Broadband, DC* to 7 GHz (* Low frequency cut off determined by external coupling capacitors)	A single amplifier covering DC* to C band. <ul style="list-style-type: none">• Reduced component inventory• Ideal for wideband applications such as instrumentation and military
Low Noise Figure: 2.3 dB at 2 GHz	Low noise figure and low current (16mA) is ideal for use as an LNA in receivers
High Gain, 18.9 dB at 2 GHz	Minimizes the effect of NF of succeeding stages.
MCLP Package	Low inductance, repeatable transitions, excellent thermal pad.

Surface Mount Monolithic Amplifier

LEE2-6+

50Ω DC to 7 GHz

Product Features

- Wideband, DC-7 GHz
- Internally Matched to 50 Ohms
- Noise figure, 2.3 dB at 2 GHz
- Low current, 16 mA



Generic photo used for illustration purposes only

CASE STYLE: MC1630-1

Typical Applications

- Cellular
- PCN instrumentation
- VHF/UHF receivers/transmitters

+RoHS Compliant

The +Suffix identifies RoHS Compliance. See our web site for RoHS Compliance methodologies and qualifications

General Description

LEE2-6+ (RoHS compliant) is wideband current driven amplifier fabricated using HBT technology. In addition, the LEE2-6+, has good input and output return loss over a broad frequency range without the need for external matching components. Lead finish is Tin Silver over Nickel. It has repeatable performance from lot to lot and is enclosed in a 2mm x 2mm x 0.89mm 6-lead MCLP package for very good electrical performance.

simplified schematic and pin description

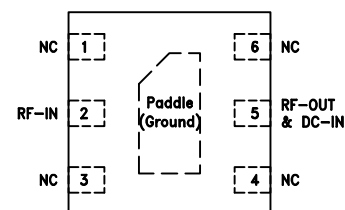
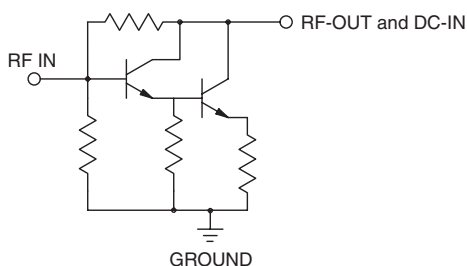

Function	Pin Number	Description
RF IN	2	RF input pin. This pin requires the use of an external DC blocking capacitor chosen for the frequency of operation.
RF-OUT and DC-IN	5	RF output and bias pin. DC voltage is present on this pin; therefore a DC blocking capacitor is necessary for proper operation. An RF choke is needed to feed DC bias without loss of RF signal due to the bias connection, as shown in "Recommended Application Circuit".
GND	Paddle	Connections to ground.
NC	1,3,4,6	No connection. Use via holes as shown in "Suggested Layout for PCB Design" to reduce ground path inductance for best performance.

Electrical Specifications¹ at 25°C and 16mA, unless noted

Parameter	Condition (GHz)	Min.	Typ.	Max.	Units
Frequency Range		DC ²		7.0	GHz
Gain	0.01	—	21.5	—	dB
	1.0	—	20.6	—	
	2.0	17.1	18.9	21.1	
	4.0	—	15.3	—	
	6.0	—	12.2	—	
	7.0	—	10.8	—	
Isolation	2.0		22.5		dB
Input return loss	0.01		29.9		dB
	1.0		21.3		
	2.0		16.0		
	4.0		11.7		
	6.0		9.3		
	7.0		8.4		
Output return loss	0.01		36.6		dB
	1.0		17.0		
	2.0		13.4		
	4.0		11.6		
	6.0		11.0		
	7.0		10.4		
Output IP3	0.01		18.9		dBm
	1.0		16.5		
	2.0		17.6		
	4.0		17.8		
	6.0		15.3		
	7.0		14.5		
Output power @ 1dB compression	0.01		4.3		dBm
	1.0		2.9		
	2.0		2.8		
	4.0		3.1		
	6.0		2.2		
	7.0		1.2		
Noise figure	0.01		2.4		dB
	1.0		2.2		
	2.0		2.3		
	4.0		2.5		
	6.0		2.9		
	7.0		3.1		
Device Operating Current (I _{bias})			16		mA
Device Voltage (V _b)			3.6		V
Device Voltage Variation vs Temperature at 16mA			-3		mV/°C
Device Voltage Variation vs Current at 25°C			10.6		mV/mA
Thermal Resistance, Junction-to-case ³			95		°C/W

1. Measured on Mini-Circuits Characterization test board TB-621+. See characterization test circuit. (Fig. 1)

2. Low frequency cut-off determined by external coupling capacitor.

Absolute Maximum Ratings⁴

Parameter	Ratings
Operating temperature	-40°C to 85°C
Storage temperature	-65°C to 150°C
Operating current	50 mA
Power dissipation	200 mW
Input power (5 minutes max.)	29 dBm
Input power (continuous operation)	See Fig. 3

3. Case is defined as ground lead.

4. Permanent damage may occur if any of these limits are exceeded.

These ratings are not intended for continuous normal operation.

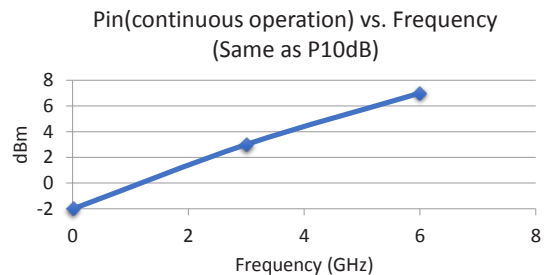

Fig 3. Power Input vs. Frequency

Characterization Test Circuit

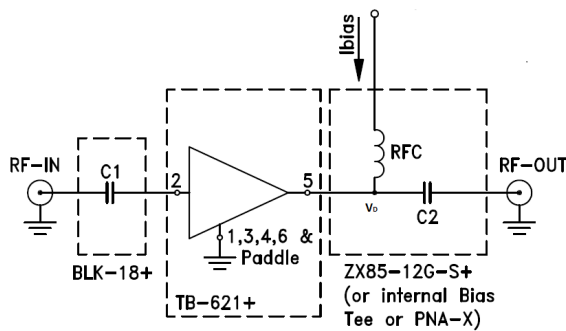
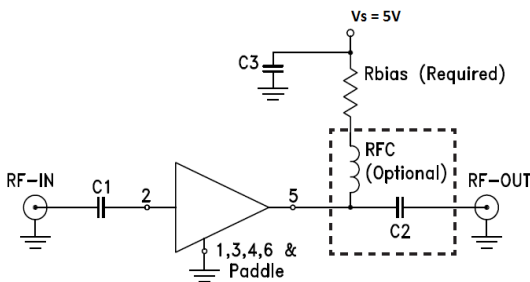

Fig 1. Block Diagram of Test Circuit used for characterization. (DUT soldered on Mini-Circuits Test Board TB-621+. Gain, Return Loss, Output Power at 1 dB Compression (P1 dB), Output IP3 (OIP3) and Noise Figure measured using key signal N5242A, PNA-X microwave network analyzer. Conditions:

1. I_{bias}=16mA
2. Gain and Return loss: -25dBm
3. Output IP3: Two tones, spaced 1 MHz apart, -8 dBm/tone at output.

Recommended Application Circuit



Component	Value	Size	Part Number	Manufacturer
C1, C2	2400 pF	0805	—	Various
RF C	—	0.15"X0.15"	TCCH-80+	Mini-Circuits
Rbias	93.1Ω	0402	—	Various
C3	0.1μF	0805	—	Various

Fig 2. Evaluation Board TB-899+ includes case, connectors and components soldered to PCB.

Product Marking

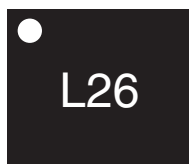

Marking may contain other features or characters for internal lot control

Additional Detailed Technical Information	
<i>additional information is available on our dash board. To access this information click here</i>	
Performance Data	Data Table
	Swept Graphs
	S-Parameter (S2P Files) Data Set (.zip file)
Case Style	MC1630-1, <i>Plastic package, lead finish: tin-silver over nickel</i>
Tape & Reel	F66 <i>7" Reels with 20, 50, 100, 200, 500, 1K, or 2K devices</i>
Suggested Layout for PCB Design	PL-349
Evaluation Board	TB-899+
Environmental Ratings	ENV08T1

ESD Rating

Human Body Model (HBM): Class 1C (1000 to <2000V) in accordance with ANSI/ESD STM 5.1 - 2001

Machine Model (MM): Class M2 (100V) in accordance with ANSI/ESD STM5.2-1999

MSL Rating

Moisture Sensitivity: MSL1 in accordance with IPC/JEDEC J-STD-020D

MSL Test Flow Chart

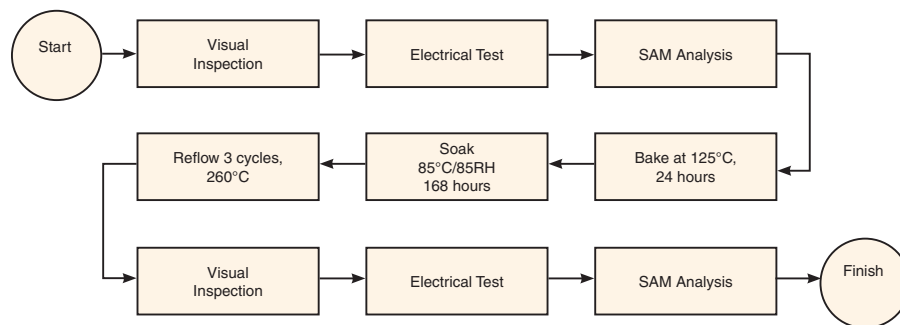

Typical Performance Data

NOTE: Use PDF Bookmarks to view DATA at required conditions

Definitions:

Input Return Loss = -S11 (dB)

Gain(Power Gain) = S21 (dB)

Reverse Isolation = -S12 (dB)

Output Return Loss = -S22 (dB)

TEST CONDITIONS: Vd = 3.59V, Id = 16.00mA @ Temperature = +25°C

FREQ	Gain	Isolation	Input Return Loss	Output Return Loss	Stability		IP-3 Output	1dB Comp. Output	Noise Figure
					K	Measure			
(MHz)	(dB)	(dB)	(dB)	(dB)	K	Measure	(dBm)	(dBm)	(dB)
10	21.45	23.37	33.53	38.14	1.02	0.36	19.19	4.51	2.40
20	21.44	23.35	34.26	40.32	1.02	0.36	22.40	4.02	2.07
30	21.44	23.38	35.16	47.24	1.03	0.37	21.59	4.30	2.15
50	21.39	23.41	33.28	42.67	1.03	0.37	19.02	2.87	2.08
100	21.39	23.34	33.30	33.58	1.03	0.36	18.07	3.71	2.04
200	21.35	23.36	31.23	28.61	1.03	0.37	17.81	3.39	2.03
300	21.31	23.35	29.69	26.26	1.03	0.38	18.38	3.29	2.07
400	21.26	23.36	28.30	24.34	1.03	0.39	18.99	3.52	2.06
500	21.17	23.33	26.52	22.29	1.02	0.40	17.70	3.21	2.10
600	21.08	23.34	25.54	20.82	1.02	0.42	18.01	3.44	2.18
700	20.98	23.28	24.37	19.69	1.02	0.43	17.83	3.34	2.10
800	20.86	23.27	23.29	18.86	1.02	0.44	17.72	3.06	2.13
900	20.74	23.19	22.38	18.14	1.02	0.45	18.45	3.56	2.18
1000	20.61	23.15	21.45	17.31	1.02	0.47	16.56	2.89	2.19
1200	20.31	23.06	20.05	16.14	1.02	0.50	17.62	3.10	2.27
1400	19.98	22.92	18.82	15.29	1.02	0.52	17.96	3.30	2.27
1600	19.64	22.77	17.68	14.60	1.01	0.55	17.65	2.92	2.39
1800	19.28	22.70	16.82	14.13	1.02	0.59	17.40	2.70	2.36
2000	18.91	22.55	16.06	13.75	1.02	0.61	17.34	2.56	2.39
2200	18.54	22.36	15.35	13.41	1.02	0.64	18.02	3.08	2.35
2400	18.16	22.15	14.79	13.20	1.02	0.66	18.56	3.28	2.36
2600	17.79	21.98	14.30	13.00	1.02	0.68	17.77	2.36	2.44
2800	17.42	21.81	13.90	12.90	1.03	0.70	18.01	2.69	2.46
3000	17.07	21.64	13.52	12.74	1.03	0.72	17.88	2.65	2.43
3200	16.70	21.44	13.16	12.65	1.03	0.74	18.64	3.32	2.45
3400	16.35	21.27	12.91	12.48	1.04	0.75	18.41	3.13	2.41
3600	16.00	21.07	12.68	12.46	1.05	0.77	18.49	3.24	2.44
3800	15.67	20.94	12.50	12.37	1.05	0.78	18.18	3.02	2.47
4000	15.33	20.79	12.25	12.27	1.06	0.80	18.12	3.70	2.50
4200	15.00	20.62	12.05	12.18	1.07	0.81	17.85	3.75	2.43
4400	14.69	20.45	11.84	12.08	1.07	0.82	17.71	3.69	2.50
4600	14.36	20.35	11.66	12.00	1.09	0.83	17.49	3.62	2.51
4800	14.05	20.22	11.43	11.88	1.10	0.84	17.17	3.59	2.55
5000	13.76	20.08	11.26	11.76	1.10	0.85	17.08	2.63	2.63
5200	13.43	19.99	10.95	11.69	1.12	0.86	16.57	3.07	2.70
5400	13.12	19.86	10.61	11.55	1.13	0.87	16.16	3.37	2.72
5600	12.80	19.77	10.35	11.46	1.14	0.88	16.05	3.06	2.66
5800	12.51	19.69	10.09	11.33	1.15	0.89	15.92	2.61	2.70
6000	12.22	19.59	9.73	11.20	1.16	0.91	15.85	2.30	2.75
6200	11.91	19.53	9.37	11.11	1.17	0.92	15.34	2.34	2.82
6400	11.60	19.51	9.07	11.01	1.18	0.94	15.13	2.29	2.88
6600	11.31	19.43	8.76	10.93	1.19	0.95	15.22	2.05	2.93
6800	11.02	19.40	8.45	10.82	1.20	0.96	14.93	1.77	3.00
7000	10.73	19.35	8.12	10.75	1.21	0.98	14.66	1.60	3.12
7200	10.43	19.33	7.82	10.66	1.23	1.00	14.40	1.50	3.14
7400	10.14	19.32	7.52	10.52	1.24	1.01	14.10	1.42	3.25
7600	9.86	19.28	7.27	10.45	1.25	1.03	14.05	1.15	3.27
7800	9.56	19.27	7.01	10.30	1.26	1.04	13.80	1.03	3.37
8000	9.27	19.26	6.76	10.12	1.27	1.05	13.45	1.03	3.42

Typical Performance Data

Definitions:

Input Return Loss = -S11 (dB)

Gain(Power Gain) = S21 (dB)

Reverse Isolation = -S12 (dB)

Output Return Loss = -S22 (dB)

TEST CONDITIONS: Vd = 3.55V, Id = 12.00mA @ Temperature = +25°C

FREQ	Gain	Isolation	Input Return Loss	Output Return Loss	Stability		IP-3 Output	1dB Comp. Output	Noise Figure
					K	Measure			
(MHz)	(dB)	(dB)	(dB)	(dB)	K	Measure	(dBm)	(dBm)	(dB)
10	19.07	21.61	13.39	12.57	1.03	0.35	23.28	-0.15	2.54
20	19.08	21.69	13.62	13.15	1.03	0.38	19.61	-0.63	2.25
30	19.07	21.69	13.58	13.21	1.03	0.38	20.14	-0.43	2.31
50	19.02	21.75	13.49	13.56	1.04	0.40	21.40	-1.44	2.26
100	19.01	21.67	13.47	13.05	1.03	0.38	18.59	-0.84	2.16
200	18.99	21.67	13.44	13.04	1.03	0.39	18.17	-1.09	2.21
300	18.96	21.66	13.40	13.07	1.03	0.40	18.56	-1.17	2.30
400	18.95	21.66	13.38	13.11	1.03	0.41	19.19	-1.01	2.28
500	18.88	21.61	13.20	12.84	1.02	0.41	18.29	-1.19	2.30
600	18.82	21.62	13.11	12.92	1.02	0.43	17.20	-1.07	2.34
700	18.74	21.53	12.93	12.52	1.02	0.43	16.26	-1.16	2.31
800	18.66	21.52	12.78	12.55	1.01	0.45	16.25	-1.39	2.27
900	18.58	21.42	12.62	12.22	1.01	0.45	16.53	-1.01	2.35
1000	18.49	21.37	12.40	11.99	1.00	0.46	14.88	-1.49	2.31
1200	18.27	21.25	12.03	11.67	0.99	0.49	15.48	-1.44	2.44
1400	18.03	21.07	11.64	11.26	0.97	0.51	15.41	-1.29	2.45
1600	17.76	20.87	11.20	10.88	0.96	0.53	15.42	-1.64	2.51
1800	17.50	20.85	10.91	11.01	0.95	0.58	15.15	-1.89	2.50
2000	17.23	20.69	10.59	10.84	0.94	0.60	15.37	-1.97	2.55
2200	16.93	20.46	10.27	10.48	0.93	0.62	15.97	-1.54	2.49
2400	16.61	20.20	10.06	10.29	0.92	0.63	16.32	-1.45	2.49
2600	16.35	20.05	9.88	10.25	0.92	0.66	16.14	-2.21	2.56
2800	16.05	19.91	9.72	10.29	0.91	0.68	16.34	-1.90	2.60
3000	15.79	19.77	9.57	10.27	0.91	0.71	17.26	-1.80	2.55
3200	15.46	19.50	9.39	10.07	0.90	0.72	17.76	-1.24	2.54
3400	15.18	19.35	9.33	9.94	0.90	0.73	17.88	-1.33	2.51
3600	14.89	19.16	9.26	10.01	0.90	0.75	18.64	-1.10	2.52
3800	14.62	19.13	9.25	10.18	0.90	0.77	18.70	-1.21	2.56
4000	14.32	19.04	9.11	10.28	0.91	0.80	18.71	-0.26	2.57
4200	14.04	18.88	9.04	10.25	0.91	0.82	18.51	-0.01	2.51
4400	13.77	18.71	8.97	10.17	0.91	0.83	18.26	0.07	2.56
4600	13.47	18.76	8.94	10.52	0.93	0.86	17.83	0.21	2.59
4800	13.20	18.72	8.87	10.64	0.94	0.88	17.39	0.32	2.62
5000	12.96	18.67	8.91	10.62	0.95	0.89	18.45	-0.69	2.66
5200	12.65	18.64	8.69	10.79	0.97	0.91	16.81	0.12	2.72
5400	12.35	18.57	8.45	10.78	0.97	0.93	16.18	0.83	2.77
5600	12.04	18.58	8.37	10.87	0.99	0.95	15.87	0.52	2.77
5800	11.77	18.61	8.27	10.92	1.01	0.96	15.75	0.08	2.76
6000	11.51	18.64	8.06	10.88	1.02	0.98	16.07	-0.26	2.80
6200	11.20	18.69	7.80	10.90	1.04	1.00	15.54	-0.01	2.83
6400	10.89	18.79	7.58	10.83	1.06	1.02	14.90	0.21	2.90
6600	10.58	18.81	7.41	10.80	1.08	1.04	14.97	-0.03	2.99
6800	10.32	18.92	7.19	10.80	1.11	1.05	14.60	-0.33	3.02
7000	10.03	18.97	6.96	10.72	1.12	1.07	14.59	-0.40	3.18
7200	9.72	19.08	6.72	10.68	1.15	1.09	14.31	-0.34	3.19
7400	9.43	19.19	6.49	10.54	1.17	1.10	14.02	-0.29	3.28
7600	9.15	19.27	6.30	10.45	1.19	1.12	13.91	-0.58	3.35
7800	8.85	19.39	6.10	10.29	1.22	1.13	13.78	-0.55	3.35
8000	8.54	19.52	5.89	10.06	1.24	1.14	13.40	-0.31	3.48

Typical Performance Data

Definitions:

Input Return Loss = -S11 (dB)

Gain(Power Gain) = S21 (dB)

Reverse Isolation = -S12 (dB)

Output Return Loss = -S22 (dB)

TEST CONDITIONS: Vd = 3.63V, Id = 20.00mA @ Temperature = +25°C

FREQ	Gain	Isolation	Input Return Loss	Output Return Loss	Stability		IP-3 Output	1dB Comp. Output	Noise Figure
					K	Measure			
(MHz)	(dB)	(dB)	(dB)	(dB)	K	Measure	(dBm)	(dBm)	(dB)
10	22.64	24.66	20.16	17.71	1.02	0.34	21.26	7.73	2.40
20	22.63	24.59	20.00	18.19	1.02	0.34	22.44	7.23	2.02
30	22.63	24.61	19.95	17.90	1.02	0.34	22.38	7.54	2.06
50	22.59	24.62	20.17	17.83	1.02	0.35	19.92	5.89	2.00
100	22.58	24.58	20.23	18.10	1.02	0.34	19.78	6.86	1.97
200	22.54	24.59	20.37	17.75	1.02	0.35	19.54	6.51	1.96
300	22.48	24.59	20.49	17.47	1.02	0.36	20.04	6.40	1.97
400	22.41	24.59	20.56	17.07	1.03	0.37	20.92	6.66	2.04
500	22.32	24.56	20.86	16.74	1.03	0.38	19.71	6.27	2.05
600	22.21	24.56	21.10	16.23	1.03	0.40	20.25	6.55	2.12
700	22.08	24.51	21.42	15.97	1.03	0.41	20.22	6.46	2.07
800	21.94	24.49	21.69	15.58	1.03	0.43	20.17	6.17	2.06
900	21.80	24.42	21.97	15.38	1.03	0.44	20.85	6.68	2.11
1000	21.64	24.37	22.24	15.03	1.03	0.45	18.93	5.94	2.11
1200	21.29	24.27	22.57	14.44	1.04	0.48	20.20	6.21	2.21
1400	20.92	24.13	22.52	14.01	1.04	0.51	20.56	6.44	2.22
1600	20.52	23.96	21.97	13.65	1.04	0.54	20.25	6.05	2.33
1800	20.12	23.83	21.20	13.32	1.05	0.57	20.00	5.81	2.36
2000	19.70	23.65	20.35	13.11	1.06	0.60	19.76	5.62	2.32
2200	19.29	23.44	19.38	12.95	1.06	0.62	20.29	6.13	2.34
2400	18.87	23.21	18.53	12.84	1.07	0.64	20.68	6.32	2.31
2600	18.47	23.01	17.71	12.71	1.07	0.66	20.00	5.35	2.38
2800	18.06	22.80	17.05	12.65	1.08	0.68	20.09	5.67	2.42
3000	17.67	22.58	16.45	12.54	1.09	0.70	19.67	5.51	2.40
3200	17.28	22.36	15.89	12.47	1.09	0.72	19.98	6.02	2.41
3400	16.90	22.15	15.44	12.36	1.10	0.73	19.65	5.75	2.40
3600	16.53	21.93	15.04	12.30	1.11	0.74	19.52	5.75	2.40
3800	16.17	21.74	14.71	12.19	1.11	0.75	19.16	5.44	2.42
4000	15.81	21.53	14.34	12.05	1.12	0.76	18.72	5.81	2.50
4200	15.47	21.33	14.01	11.93	1.13	0.77	18.45	5.67	2.43
4400	15.13	21.13	13.68	11.81	1.13	0.78	18.22	5.45	2.49
4600	14.80	20.96	13.37	11.67	1.14	0.79	17.97	5.26	2.48
4800	14.47	20.78	13.01	11.49	1.15	0.80	17.60	5.08	2.54
5000	14.16	20.60	12.67	11.35	1.15	0.80	17.52	4.37	2.59
5200	13.82	20.46	12.28	11.21	1.17	0.81	16.95	4.47	2.66
5400	13.51	20.29	11.86	11.04	1.17	0.82	16.48	4.51	2.71
5600	13.19	20.16	11.48	10.91	1.18	0.83	16.41	4.22	2.68
5800	12.89	20.03	11.10	10.76	1.19	0.84	16.30	3.83	2.71
6000	12.59	19.88	10.66	10.60	1.19	0.85	16.10	3.53	2.76
6200	12.28	19.77	10.24	10.49	1.20	0.86	15.62	3.42	2.80
6400	11.97	19.69	9.87	10.41	1.21	0.88	15.44	3.30	2.88
6600	11.68	19.57	9.50	10.31	1.21	0.89	15.54	3.10	2.97
6800	11.39	19.49	9.12	10.19	1.22	0.90	15.27	2.78	2.99
7000	11.09	19.39	8.74	10.12	1.22	0.91	14.96	2.59	3.09
7200	10.80	19.32	8.41	10.02	1.23	0.93	14.66	2.37	3.16
7400	10.51	19.26	8.07	9.91	1.24	0.94	14.34	2.26	3.23
7600	10.23	19.19	7.78	9.84	1.24	0.96	14.29	1.98	3.27
7800	9.93	19.12	7.49	9.71	1.24	0.97	14.03	1.83	3.38
8000	9.65	19.06	7.23	9.58	1.25	0.98	13.65	1.80	3.45

Typical Performance Data

Definitions:

Input Return Loss = -S11 (dB)

Gain(Power Gain) = S21 (dB)

Reverse Isolation = -S12 (dB)

Output Return Loss = -S22 (dB)

TEST CONDITIONS: Vd = 3.79V, Id = 16.00mA @ Temperature = -45°C

FREQ	Gain	Isolation	Input Return Loss	Output Return Loss	Stability		IP-3 Output	1dB Comp. Output	Noise Figure
					K	Measure			
(MHz)	(dB)	(dB)	(dB)	(dB)	K	Measure	(dBm)	(dBm)	(dB)
10	22.15	24.00	28.02	24.80	1.02	0.34	18.26	4.36	1.84
20	22.12	23.91	26.44	26.02	1.02	0.34	19.95	4.00	1.61
30	22.12	23.97	29.11	25.17	1.02	0.34	19.71	4.15	1.64
50	22.06	23.99	28.64	24.92	1.02	0.35	17.39	2.76	1.62
100	22.06	23.90	30.50	26.58	1.02	0.35	17.30	3.61	1.56
200	22.02	23.91	30.91	25.11	1.02	0.35	16.88	3.24	1.60
300	21.97	23.90	28.09	23.35	1.02	0.36	17.35	3.18	1.59
400	21.92	23.91	26.51	21.77	1.02	0.37	18.02	3.45	1.62
500	21.84	23.87	25.65	20.52	1.02	0.38	16.88	3.14	1.66
600	21.75	23.88	24.87	19.28	1.02	0.39	17.29	3.42	1.66
700	21.64	23.81	24.46	18.65	1.02	0.40	17.17	3.33	1.60
800	21.53	23.81	24.07	17.88	1.02	0.42	17.06	3.02	1.65
900	21.41	23.71	23.26	17.63	1.02	0.42	17.79	3.50	1.70
1000	21.28	23.67	22.54	17.02	1.02	0.44	16.01	2.79	1.67
1200	21.00	23.57	21.72	16.06	1.02	0.46	16.95	3.01	1.76
1400	20.69	23.41	20.43	15.41	1.02	0.49	17.38	3.28	1.73
1600	20.34	23.26	19.25	14.82	1.02	0.52	17.09	2.90	1.87
1800	19.99	23.19	18.37	14.32	1.02	0.55	16.74	2.66	1.84
2000	19.64	23.03	17.75	13.95	1.02	0.57	16.57	2.38	1.86
2200	19.28	22.83	17.14	13.55	1.02	0.59	17.29	2.91	1.84
2400	18.90	22.62	16.70	13.26	1.02	0.61	18.06	3.32	1.82
2600	18.54	22.44	16.20	12.97	1.03	0.63	17.14	2.37	1.91
2800	18.17	22.27	15.61	12.92	1.03	0.66	17.39	2.65	1.92
3000	17.84	22.10	15.12	12.86	1.04	0.67	17.05	2.52	1.89
3200	17.48	21.87	14.87	12.70	1.04	0.69	18.26	3.25	1.87
3400	17.15	21.69	14.65	12.51	1.04	0.70	18.09	3.10	1.82
3600	16.81	21.47	14.32	12.46	1.05	0.71	18.29	3.27	1.86
3800	16.48	21.34	13.99	12.30	1.05	0.73	18.01	3.05	1.87
4000	16.15	21.18	13.64	12.12	1.06	0.74	18.25	3.77	1.93
4200	15.84	21.00	13.44	11.97	1.07	0.75	18.23	4.00	1.90
4400	15.55	20.80	13.12	11.99	1.07	0.76	18.16	3.96	1.93
4600	15.23	20.66	13.02	11.83	1.08	0.76	18.31	4.10	1.90
4800	14.93	20.52	12.60	11.62	1.08	0.77	17.89	3.96	1.96
5000	14.64	20.36	12.33	11.41	1.09	0.78	17.75	3.10	2.04
5200	14.29	20.30	11.64	11.11	1.10	0.79	17.38	3.65	2.09
5400	13.98	20.15	11.31	10.95	1.10	0.81	17.07	3.94	2.12
5600	13.69	20.01	11.19	10.84	1.11	0.81	16.99	3.81	2.07
5800	13.37	19.95	10.57	10.64	1.12	0.83	16.87	3.42	2.13
6000	13.09	19.83	10.27	10.48	1.13	0.84	16.73	2.93	2.15
6200	12.78	19.77	9.77	10.38	1.13	0.86	16.24	2.94	2.21
6400	12.51	19.69	9.70	10.34	1.14	0.87	16.05	3.07	2.24
6600	12.23	19.58	9.37	10.34	1.15	0.88	16.14	2.97	2.32
6800	11.98	19.50	9.18	10.19	1.16	0.89	15.88	2.61	2.31
7000	11.71	19.41	8.79	10.29	1.16	0.91	15.65	2.41	2.46
7200	11.47	19.32	8.59	10.30	1.17	0.92	15.32	2.34	2.47
7400	11.22	19.25	8.25	10.27	1.17	0.93	15.08	2.30	2.54
7600	10.97	19.16	7.96	10.19	1.17	0.95	15.01	2.08	2.60
7800	10.71	19.10	7.67	10.06	1.18	0.96	14.76	2.02	2.53
8000	10.43	19.07	7.27	9.91	1.18	0.97	14.30	2.02	2.65

Typical Performance Data

Definitions:

Input Return Loss = -S11 (dB)

Gain(Power Gain) = S21 (dB)

Reverse Isolation = -S12 (dB)

Output Return Loss = -S22 (dB)

TEST CONDITIONS: Vd = 3.74V, Id = 12.00mA @ Temperature = -45°C

FREQ	Gain	Isolation	Input Return Loss	Output Return Loss	Stability		IP-3 Output	1dB Comp. Output	Noise Figure
					K	Measure			
(MHz)	(dB)	(dB)	(dB)	(dB)			(dBm)	(dBm)	(dB)
10	19.82	21.97	15.63	14.27	1.02	0.32	17.25	-0.46	1.92
20	19.84	22.05	16.07	15.03	1.03	0.35	23.75	-0.86	1.78
30	19.82	22.06	15.74	15.18	1.03	0.36	23.22	-0.72	1.87
50	19.74	22.15	15.62	15.67	1.03	0.39	20.10	-1.72	1.79
100	19.73	22.04	15.29	14.63	1.03	0.36	15.98	-1.12	1.73
200	19.70	22.05	15.02	14.49	1.03	0.37	15.50	-1.43	1.76
300	19.69	22.01	15.37	14.85	1.02	0.38	16.29	-1.47	1.82
400	19.69	22.00	15.56	15.11	1.02	0.38	16.88	-1.27	1.80
500	19.62	21.94	15.39	14.75	1.02	0.39	15.71	-1.44	1.78
600	19.57	21.96	15.36	14.96	1.02	0.41	15.51	-1.28	1.86
700	19.48	21.85	15.07	14.27	1.01	0.40	14.81	-1.37	1.78
800	19.41	21.86	14.86	14.22	1.01	0.42	14.78	-1.63	1.78
900	19.33	21.74	14.59	13.76	1.00	0.42	15.29	-1.25	1.84
1000	19.24	21.70	14.17	13.42	1.00	0.43	13.54	-1.76	1.88
1200	19.03	21.57	13.66	12.86	0.99	0.45	14.05	-1.73	1.93
1400	18.81	21.36	13.25	12.48	0.97	0.47	14.18	-1.54	1.94
1600	18.54	21.15	12.66	11.99	0.96	0.49	13.95	-1.87	1.97
1800	18.29	21.17	12.27	12.20	0.96	0.54	13.58	-2.14	1.99
2000	18.02	21.03	11.88	11.92	0.95	0.57	13.58	-2.34	1.98
2200	17.75	20.77	11.58	11.40	0.93	0.58	14.13	-1.96	1.96
2400	17.43	20.49	11.42	11.08	0.93	0.58	14.59	-1.64	1.93
2600	17.17	20.34	11.26	10.88	0.92	0.60	14.01	-2.45	2.02
2800	16.85	20.22	10.95	10.87	0.92	0.63	14.16	-2.25	2.02
3000	16.61	20.13	10.69	10.80	0.92	0.66	14.45	-2.23	1.97
3200	16.29	19.82	10.55	10.45	0.91	0.66	15.43	-1.60	1.98
3400	16.03	19.66	10.51	10.20	0.90	0.67	15.37	-1.71	1.95
3600	15.76	19.42	10.44	10.25	0.90	0.68	16.01	-1.46	1.93
3800	15.49	19.43	10.37	10.41	0.91	0.72	15.94	-1.61	1.97
4000	15.20	19.39	10.13	10.50	0.91	0.75	16.84	-0.73	1.99
4200	14.92	19.24	10.06	10.35	0.91	0.76	17.39	-0.36	1.92
4400	14.68	19.03	9.91	10.22	0.90	0.77	17.79	-0.29	1.99
4600	14.39	19.04	9.95	10.59	0.92	0.79	18.56	0.07	1.99
4800	14.15	19.02	9.81	10.73	0.93	0.82	18.23	0.07	1.99
5000	13.91	18.96	9.89	10.77	0.95	0.82	18.77	-0.77	2.08
5200	13.57	18.99	9.41	10.87	0.96	0.86	18.07	0.00	2.12
5400	13.28	18.90	9.10	10.70	0.95	0.88	17.51	0.68	2.16
5600	12.98	18.87	9.13	10.69	0.97	0.89	17.39	0.71	2.16
5800	12.67	18.92	8.83	10.78	0.99	0.92	17.40	0.31	2.12
6000	12.43	18.95	8.65	10.66	1.00	0.93	17.67	-0.23	2.19
6200	12.12	19.03	8.25	10.64	1.01	0.96	17.11	-0.01	2.23
6400	11.82	19.09	8.18	10.47	1.03	0.97	16.28	0.46	2.26
6600	11.53	19.10	7.95	10.51	1.05	0.99	16.30	0.51	2.32
6800	11.30	19.15	7.85	10.42	1.07	1.00	15.93	0.05	2.39
7000	11.04	19.19	7.54	10.48	1.08	1.02	15.97	-0.04	2.46
7200	10.79	19.22	7.37	10.50	1.10	1.03	15.52	0.08	2.54
7400	10.55	19.28	7.10	10.50	1.12	1.05	15.18	0.24	2.55
7600	10.30	19.30	6.89	10.46	1.13	1.06	15.09	-0.05	2.60
7800	10.04	19.37	6.66	10.41	1.15	1.08	14.91	-0.02	2.60
8000	9.75	19.47	6.31	10.29	1.16	1.10	14.32	0.35	2.69

Typical Performance Data

Definitions:

Input Return Loss = -S11 (dB)

Gain(Power Gain) = S21 (dB)

Reverse Isolation = -S12 (dB)

Output Return Loss = -S22 (dB)

TEST CONDITIONS: Vd = 3.82V, Id = 20.00mA @ Temperature = -45°C

FREQ	Gain	Isolation	Input Return Loss	Output Return Loss	Stability		IP-3 Output	1dB Comp. Output	Noise Figure
					K	Measure			
(MHz)	(dB)	(dB)	(dB)	(dB)	K	Measure	(dBm)	(dBm)	(dB)
10	23.21	25.36	16.39	14.39	1.02	0.32	20.44	7.71	1.82
20	23.19	25.20	16.17	14.90	1.02	0.32	21.48	7.27	1.53
30	23.20	25.25	16.43	14.70	1.02	0.32	21.18	7.52	1.60
50	23.15	25.24	16.47	14.77	1.02	0.33	18.66	5.87	1.57
100	23.15	25.17	16.94	15.25	1.02	0.33	19.13	6.85	1.49
200	23.11	25.18	17.26	15.17	1.02	0.33	18.63	6.42	1.55
300	23.04	25.18	16.84	14.70	1.02	0.34	19.17	6.38	1.51
400	22.96	25.19	16.68	14.30	1.02	0.35	20.08	6.68	1.57
500	22.86	25.15	16.75	14.08	1.02	0.36	18.94	6.29	1.59
600	22.75	25.15	16.79	13.74	1.03	0.37	19.68	6.63	1.62
700	22.63	25.09	17.09	13.68	1.03	0.38	19.71	6.54	1.56
800	22.50	25.07	17.40	13.50	1.03	0.40	19.87	6.23	1.58
900	22.36	24.98	17.67	13.53	1.03	0.41	20.73	6.76	1.62
1000	22.21	24.93	18.06	13.41	1.03	0.42	18.90	5.94	1.62
1200	21.89	24.80	18.84	13.22	1.04	0.45	19.99	6.22	1.72
1400	21.52	24.64	19.06	12.95	1.04	0.48	20.48	6.52	1.69
1600	21.14	24.46	19.34	12.76	1.04	0.50	20.19	6.12	1.82
1800	20.75	24.31	19.53	12.55	1.05	0.53	19.91	5.88	1.85
2000	20.35	24.11	19.76	12.46	1.06	0.56	19.60	5.57	1.83
2200	19.95	23.89	19.56	12.31	1.06	0.58	20.18	6.09	1.79
2400	19.54	23.66	19.32	12.16	1.07	0.59	20.89	6.51	1.78
2600	19.14	23.43	18.88	12.05	1.07	0.61	20.12	5.51	1.83
2800	18.75	23.21	18.36	12.11	1.08	0.63	20.26	5.78	1.86
3000	18.38	22.98	17.89	12.19	1.08	0.65	19.72	5.58	1.89
3200	18.01	22.73	17.61	12.11	1.09	0.66	20.39	6.25	1.87
3400	17.65	22.50	17.26	12.04	1.09	0.67	20.21	6.04	1.82
3600	17.29	22.25	16.68	11.92	1.10	0.68	20.17	6.10	1.81
3800	16.93	22.06	16.17	11.78	1.10	0.69	19.84	5.81	1.84
4000	16.58	21.84	15.68	11.62	1.11	0.70	19.60	6.31	1.92
4200	16.25	21.62	15.40	11.51	1.11	0.71	19.26	6.30	1.85
4400	15.94	21.39	14.97	11.52	1.11	0.72	19.10	6.11	1.90
4600	15.62	21.19	14.74	11.31	1.12	0.72	19.00	6.10	1.93
4800	15.30	21.00	14.10	11.05	1.13	0.73	18.60	5.84	1.97
5000	14.99	20.81	13.63	10.80	1.13	0.73	18.59	5.16	2.03
5200	14.63	20.69	12.78	10.42	1.14	0.74	18.00	5.34	2.08
5400	14.32	20.51	12.41	10.29	1.14	0.75	17.52	5.31	2.14
5600	14.03	20.33	12.21	10.19	1.14	0.75	17.44	5.13	2.09
5800	13.70	20.22	11.43	9.92	1.15	0.77	17.34	4.79	2.13
6000	13.41	20.06	11.07	9.79	1.15	0.77	17.17	4.36	2.17
6200	13.10	19.94	10.51	9.68	1.15	0.79	16.65	4.23	2.20
6400	12.84	19.81	10.45	9.68	1.16	0.80	16.41	4.18	2.24
6600	12.56	19.66	10.06	9.66	1.16	0.81	16.47	4.04	2.33
6800	12.30	19.53	9.83	9.54	1.16	0.82	16.27	3.70	2.37
7000	12.04	19.40	9.41	9.62	1.17	0.84	16.01	3.51	2.45
7200	11.80	19.26	9.19	9.64	1.17	0.85	15.64	3.33	2.49
7400	11.55	19.15	8.83	9.60	1.17	0.86	15.38	3.25	2.58
7600	11.30	19.03	8.49	9.50	1.17	0.87	15.33	2.93	2.58
7800	11.04	18.93	8.16	9.38	1.17	0.88	15.07	2.83	2.71
8000	10.76	18.85	7.74	9.25	1.17	0.90	14.53	2.75	2.70

Typical Performance Data

Definitions:

Input Return Loss = -S11 (dB)

Gain(Power Gain) = S21 (dB)

Reverse Isolation = -S12 (dB)

Output Return Loss = -S22 (dB)

TEST CONDITIONS: Vd = 3.42V, Id = 16.00mA @ Temperature = +85°C

FREQ	Gain	Isolation	Input Return Loss	Output Return Loss	Stability		IP-3 Output	1dB Comp. Output	Noise Figure
					K	Measure			
(MHz)	(dB)	(dB)	(dB)	(dB)	K	Measure	(dBm)	(dBm)	(dB)
10	20.88	22.98	23.72	25.33	1.03	0.37	20.71	4.55	2.97
20	20.88	22.94	24.74	25.37	1.03	0.38	23.98	4.14	2.61
30	20.87	22.95	23.86	26.02	1.03	0.38	23.17	4.31	2.64
50	20.84	22.98	24.45	26.73	1.03	0.39	20.61	3.01	2.55
100	20.83	22.92	25.06	25.81	1.03	0.38	18.79	3.82	2.41
200	20.80	22.93	25.22	25.35	1.03	0.39	18.54	3.55	2.45
300	20.75	22.94	24.36	23.89	1.03	0.40	19.37	3.46	2.49
400	20.69	22.95	23.36	22.33	1.03	0.41	20.08	3.62	2.47
500	20.60	22.92	22.24	20.54	1.03	0.42	18.47	3.34	2.56
600	20.50	22.94	21.52	19.50	1.03	0.44	18.69	3.50	2.56
700	20.39	22.89	20.57	18.47	1.03	0.45	18.39	3.38	2.54
800	20.26	22.88	19.74	17.80	1.03	0.47	18.29	3.07	2.56
900	20.13	22.81	19.04	17.06	1.02	0.48	19.01	3.54	2.59
1000	19.99	22.77	18.33	16.35	1.02	0.49	16.92	2.92	2.58
1200	19.69	22.68	17.18	15.34	1.02	0.52	18.06	3.08	2.69
1400	19.35	22.55	16.20	14.56	1.02	0.55	18.30	3.23	2.70
1600	18.99	22.39	15.34	13.96	1.01	0.58	18.03	2.87	2.84
1800	18.63	22.30	14.68	13.63	1.02	0.62	17.92	2.67	2.86
2000	18.25	22.14	14.15	13.34	1.02	0.64	17.98	2.67	2.87
2200	17.87	21.95	13.61	13.06	1.02	0.67	18.49	3.18	2.87
2400	17.47	21.74	13.16	12.91	1.02	0.69	18.83	3.21	2.85
2600	17.10	21.56	12.77	12.79	1.02	0.72	18.27	2.37	2.93
2800	16.72	21.40	12.41	12.77	1.03	0.74	18.43	2.72	2.97
3000	16.35	21.23	12.12	12.70	1.03	0.76	18.37	2.72	2.93
3200	15.96	21.03	11.80	12.67	1.03	0.78	18.55	3.27	2.98
3400	15.60	20.87	11.59	12.58	1.04	0.80	18.28	3.11	2.91
3600	15.24	20.69	11.40	12.68	1.05	0.81	18.10	3.10	3.00
3800	14.89	20.57	11.24	12.71	1.06	0.83	17.81	2.90	2.98
4000	14.53	20.41	11.05	12.68	1.07	0.85	17.39	3.43	3.05
4200	14.19	20.27	10.93	12.63	1.09	0.86	17.03	3.38	3.01
4400	13.85	20.12	10.78	12.51	1.09	0.87	16.80	3.25	3.12
4600	13.51	20.03	10.67	12.40	1.11	0.88	16.49	3.07	3.08
4800	13.18	19.93	10.54	12.28	1.13	0.89	16.20	2.99	3.12
5000	12.87	19.80	10.42	12.15	1.14	0.90	16.15	2.18	3.21
5200	12.53	19.73	10.25	12.06	1.16	0.91	15.62	2.49	3.26
5400	12.20	19.62	9.95	11.86	1.17	0.92	15.10	2.71	3.31
5600	11.88	19.55	9.70	11.83	1.18	0.94	15.08	2.25	3.31
5800	11.57	19.49	9.44	11.70	1.20	0.95	14.98	1.83	3.30
6000	11.25	19.43	9.13	11.62	1.21	0.96	14.90	1.63	3.39
6200	10.93	19.38	8.77	11.50	1.23	0.98	14.36	1.63	3.37
6400	10.61	19.38	8.44	11.35	1.24	0.99	14.18	1.52	3.50
6600	10.28	19.36	8.12	11.22	1.26	1.01	14.29	1.18	3.63
6800	9.96	19.37	7.79	11.02	1.28	1.02	13.93	0.95	3.66
7000	9.64	19.36	7.49	10.85	1.29	1.04	13.67	0.79	3.82
7200	9.30	19.39	7.19	10.65	1.31	1.05	13.47	0.67	3.92
7400	8.98	19.42	6.91	10.42	1.32	1.07	13.15	0.52	4.02
7600	8.66	19.44	6.69	10.30	1.34	1.08	13.07	0.28	4.07
7800	8.35	19.45	6.46	10.08	1.35	1.09	12.83	0.05	4.11
8000	8.04	19.48	6.27	9.92	1.37	1.10	12.68	0.06	4.23

Typical Performance Data

Definitions:

Input Return Loss = -S11 (dB)

Gain(Power Gain) = S21 (dB)

Reverse Isolation = -S12 (dB)

Output Return Loss = -S22 (dB)

TEST CONDITIONS: Vd = 3.37V, Id = 12.00mA @ Temperature = +85°C

FREQ	Gain	Isolation	Input Return Loss	Output Return Loss	Stability		IP-3 Output	1dB Comp. Output	Noise Figure
					K	Measure			
(MHz)	(dB)	(dB)	(dB)	(dB)	K	Measure	(dBm)	(dBm)	(dB)
10	18.48	21.35	12.14	11.49	1.03	0.37	24.87	0.07	3.16
20	18.50	21.43	12.33	11.95	1.04	0.40	17.55	-0.37	2.79
30	18.48	21.42	12.21	11.99	1.04	0.40	17.95	-0.22	2.82
50	18.46	21.46	12.34	12.29	1.04	0.41	17.81	-1.18	2.72
100	18.45	21.38	12.47	12.06	1.04	0.40	20.17	-0.58	2.59
200	18.44	21.37	12.62	12.24	1.03	0.41	20.00	-0.79	2.63
300	18.41	21.37	12.51	12.20	1.03	0.42	18.97	-0.86	2.73
400	18.37	21.39	12.32	12.11	1.03	0.43	19.29	-0.73	2.69
500	18.29	21.35	12.09	11.78	1.03	0.43	19.64	-0.93	2.68
600	18.22	21.37	11.95	11.77	1.03	0.45	17.76	-0.84	2.73
700	18.13	21.30	11.71	11.43	1.02	0.46	16.85	-0.96	2.66
800	18.04	21.29	11.49	11.37	1.02	0.47	16.79	-1.21	2.72
900	17.95	21.21	11.29	11.09	1.01	0.48	16.83	-0.83	2.76
1000	17.84	21.16	11.07	10.87	1.00	0.49	15.64	-1.32	2.76
1200	17.61	21.05	10.68	10.58	0.99	0.52	16.08	-1.29	2.86
1400	17.35	20.87	10.32	10.24	0.98	0.54	15.97	-1.19	2.91
1600	17.08	20.67	9.97	9.97	0.96	0.56	16.26	-1.50	2.98
1800	16.82	20.61	9.74	10.10	0.95	0.60	16.09	-1.73	3.02
2000	16.55	20.42	9.53	10.03	0.94	0.63	16.51	-1.70	2.99
2200	16.24	20.18	9.29	9.83	0.93	0.65	17.25	-1.24	2.97
2400	15.93	19.93	9.12	9.73	0.92	0.66	17.47	-1.26	2.94
2600	15.66	19.76	8.97	9.78	0.91	0.69	17.80	-1.94	3.03
2800	15.35	19.61	8.84	9.91	0.91	0.72	17.94	-1.60	3.04
3000	15.07	19.45	8.72	9.96	0.91	0.74	19.12	-1.46	3.00
3200	14.72	19.19	8.58	9.88	0.90	0.76	18.53	-0.89	3.07
3400	14.43	19.05	8.52	9.88	0.90	0.78	18.28	-0.96	3.00
3600	14.12	18.88	8.46	10.06	0.91	0.80	18.34	-0.76	3.07
3800	13.84	18.83	8.44	10.31	0.92	0.83	18.01	-0.85	3.08
4000	13.52	18.72	8.35	10.47	0.92	0.85	17.20	-0.04	3.15
4200	13.22	18.58	8.32	10.54	0.93	0.87	16.78	0.18	3.07
4400	12.92	18.44	8.29	10.54	0.93	0.88	16.48	0.25	3.15
4600	12.61	18.49	8.31	10.82	0.96	0.91	15.95	0.22	3.12
4800	12.32	18.46	8.28	10.94	0.97	0.93	15.68	0.35	3.19
5000	12.06	18.39	8.33	10.89	0.98	0.93	16.02	-0.63	3.24
5200	11.73	18.39	8.22	11.05	1.00	0.95	15.21	0.07	3.34
5400	11.40	18.34	8.02	10.98	1.01	0.97	14.72	0.62	3.35
5600	11.09	18.37	7.93	11.10	1.04	0.99	14.54	0.16	3.29
5800	10.81	18.41	7.83	11.15	1.06	1.01	14.39	-0.34	3.36
6000	10.52	18.45	7.62	11.13	1.08	1.02	14.70	-0.45	3.43
6200	10.20	18.50	7.36	11.16	1.10	1.05	14.23	-0.26	3.46
6400	9.87	18.61	7.14	11.05	1.12	1.06	13.78	-0.25	3.53
6600	9.55	18.67	6.95	10.99	1.15	1.08	13.85	-0.64	3.67
6800	9.24	18.81	6.71	10.88	1.18	1.10	13.57	-0.80	3.74
7000	8.92	18.91	6.49	10.70	1.20	1.11	13.50	-0.81	3.85
7200	8.58	19.06	6.25	10.53	1.23	1.13	13.34	-0.94	3.95
7400	8.25	19.22	6.03	10.26	1.26	1.14	13.07	-0.93	4.05
7600	7.93	19.34	5.87	10.05	1.29	1.15	12.99	-1.27	4.12
7800	7.61	19.48	5.68	9.78	1.31	1.16	12.84	-1.32	4.24
8000	7.28	19.66	5.51	9.52	1.35	1.17	12.67	-1.23	4.32

Typical Performance Data

Definitions:

Input Return Loss = -S11 (dB)

Gain(Power Gain) = S21 (dB)

Reverse Isolation = -S12 (dB)

Output Return Loss = -S22 (dB)

TEST CONDITIONS: Vd = 3.46V, Id = 20.00mA @ Temperature = +85°C

FREQ	Gain	Isolation	Input Return Loss	Output Return Loss	Stability		IP-3 Output	1dB Comp. Output	Noise Figure
					K	Measure			
(MHz)	(dB)	(dB)	(dB)	(dB)	K	Measure	(dBm)	(dBm)	(dB)
10	22.12	24.14	25.79	21.96	1.02	0.36	21.83	7.75	2.90
20	22.12	24.08	24.95	22.43	1.02	0.36	24.63	7.25	2.51
30	22.12	24.12	25.48	21.96	1.03	0.36	23.78	7.51	2.54
50	22.09	24.12	24.94	21.62	1.03	0.37	21.15	5.96	2.46
100	22.08	24.08	24.32	21.45	1.03	0.36	20.48	6.90	2.36
200	22.03	24.10	23.65	20.32	1.03	0.37	20.20	6.59	2.37
300	21.97	24.11	24.11	19.93	1.03	0.38	20.90	6.47	2.39
400	21.90	24.11	24.86	19.43	1.03	0.39	21.57	6.72	2.42
500	21.80	24.09	25.75	18.85	1.03	0.41	20.10	6.30	2.44
600	21.68	24.09	26.23	18.11	1.03	0.42	20.56	6.53	2.49
700	21.55	24.04	26.69	17.70	1.03	0.43	20.46	6.41	2.46
800	21.40	24.03	26.76	17.18	1.03	0.45	20.31	6.12	2.48
900	21.25	23.96	26.60	16.79	1.03	0.47	21.09	6.58	2.54
1000	21.09	23.92	25.94	16.28	1.03	0.48	18.98	5.88	2.47
1200	20.73	23.82	24.35	15.46	1.04	0.52	20.26	6.11	2.64
1400	20.34	23.68	22.54	14.84	1.04	0.55	20.46	6.27	2.65
1600	19.94	23.53	20.87	14.34	1.05	0.58	20.21	5.91	2.81
1800	19.51	23.39	19.52	13.92	1.05	0.61	20.04	5.66	2.81
2000	19.09	23.21	18.48	13.61	1.06	0.64	19.91	5.61	2.81
2200	18.66	23.01	17.46	13.39	1.06	0.66	20.23	6.10	2.80
2400	18.23	22.79	16.60	13.23	1.07	0.68	20.40	6.07	2.80
2600	17.81	22.59	15.86	13.10	1.07	0.70	19.87	5.19	2.89
2800	17.39	22.39	15.24	13.04	1.08	0.73	19.80	5.47	2.87
3000	16.98	22.18	14.72	12.94	1.09	0.74	19.43	5.35	2.89
3200	16.57	21.97	14.21	12.89	1.10	0.76	19.35	5.69	2.92
3400	16.18	21.77	13.84	12.79	1.11	0.78	18.99	5.39	2.87
3600	15.79	21.57	13.49	12.80	1.12	0.79	18.70	5.29	2.94
3800	15.41	21.39	13.20	12.76	1.13	0.81	18.34	4.98	2.93
4000	15.04	21.20	12.89	12.65	1.14	0.82	17.84	5.18	3.00
4200	14.68	21.02	12.67	12.52	1.15	0.83	17.48	4.95	2.98
4400	14.32	20.84	12.40	12.34	1.16	0.84	17.23	4.72	3.05
4600	13.96	20.69	12.20	12.15	1.17	0.85	16.92	4.49	3.04
4800	13.62	20.54	11.97	11.98	1.18	0.85	16.56	4.25	3.13
5000	13.30	20.38	11.73	11.81	1.19	0.86	16.51	3.65	3.17
5200	12.95	20.27	11.49	11.65	1.21	0.87	15.94	3.66	3.26
5400	12.62	20.11	11.12	11.43	1.22	0.88	15.40	3.64	3.25
5600	12.29	20.00	10.76	11.36	1.23	0.89	15.41	3.30	3.25
5800	11.97	19.88	10.41	11.20	1.24	0.90	15.32	2.93	3.31
6000	11.65	19.78	10.00	11.10	1.25	0.91	15.09	2.68	3.38
6200	11.33	19.68	9.57	10.94	1.26	0.92	14.59	2.62	3.41
6400	11.00	19.62	9.17	10.79	1.27	0.94	14.45	2.45	3.49
6600	10.68	19.55	8.78	10.64	1.28	0.95	14.62	2.10	3.61
6800	10.36	19.51	8.40	10.45	1.29	0.97	14.20	1.90	3.70
7000	10.03	19.46	8.06	10.30	1.30	0.98	13.87	1.56	3.83
7200	9.70	19.43	7.71	10.12	1.31	1.00	13.65	1.47	3.89
7400	9.38	19.41	7.40	9.93	1.32	1.01	13.30	1.28	4.03
7600	9.06	19.38	7.14	9.84	1.34	1.02	13.23	1.02	4.08
7800	8.75	19.33	6.88	9.68	1.34	1.04	12.98	0.85	4.16
8000	8.45	19.31	6.68	9.58	1.35	1.05	12.81	0.78	4.27

Typical Performance Curves

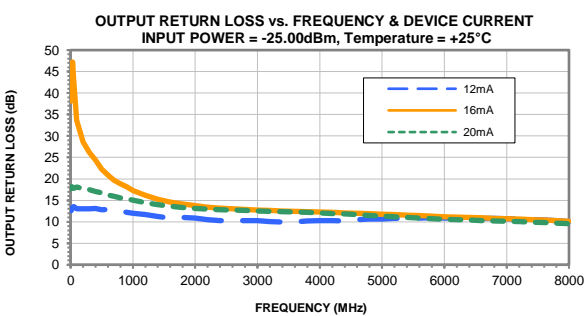
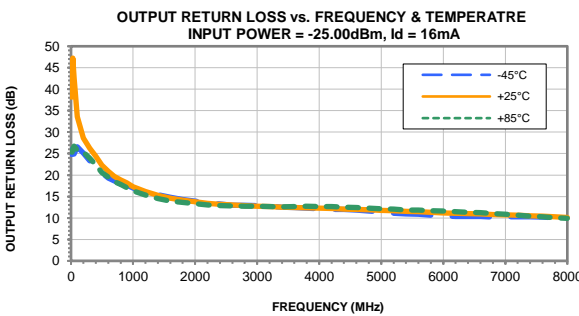
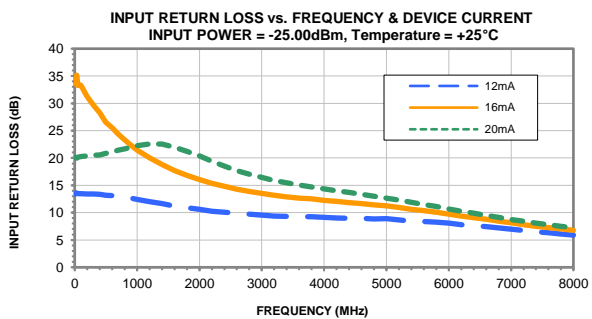
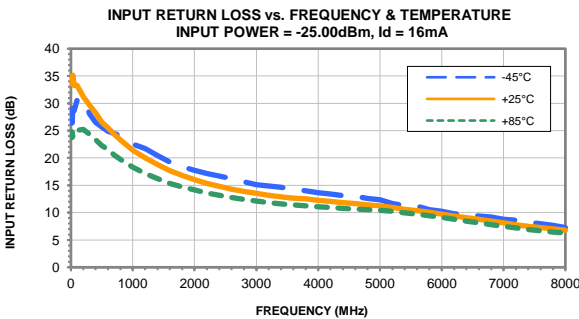
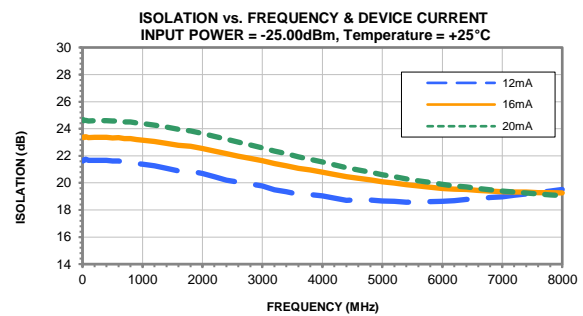
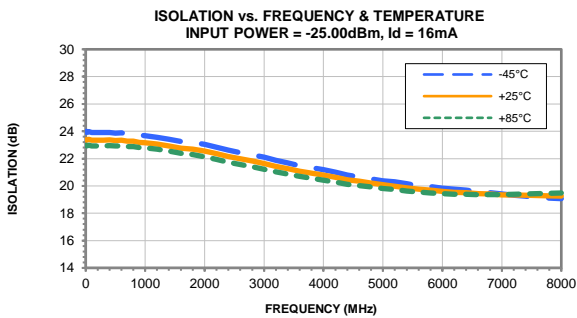
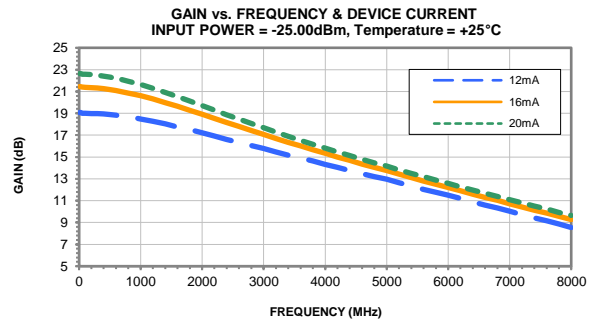
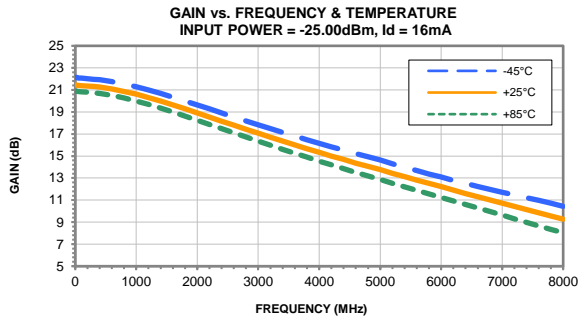

Typical Performance Curves

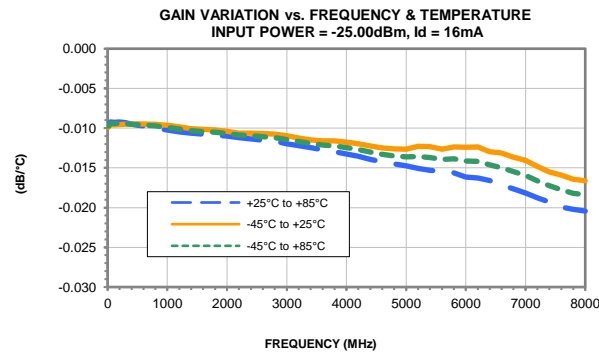
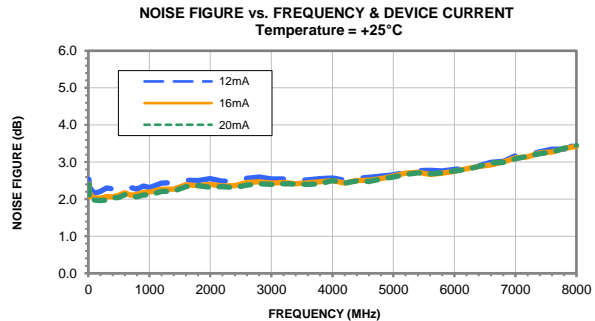
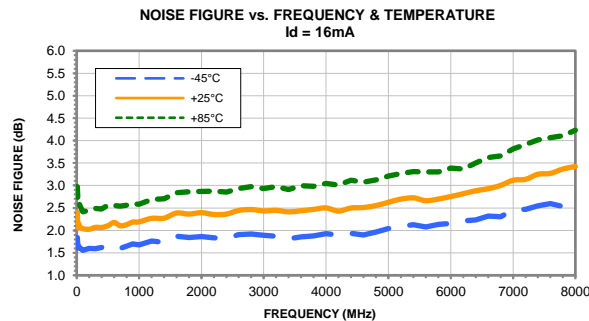
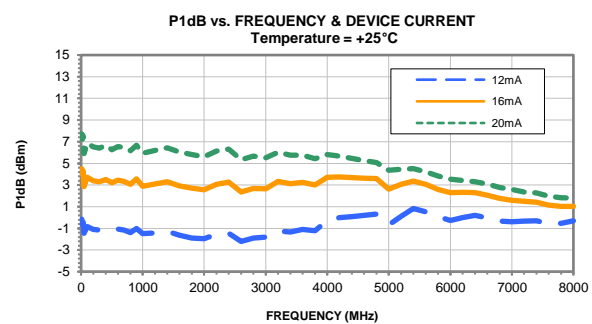
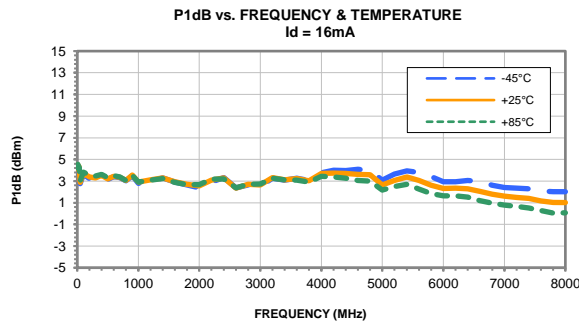
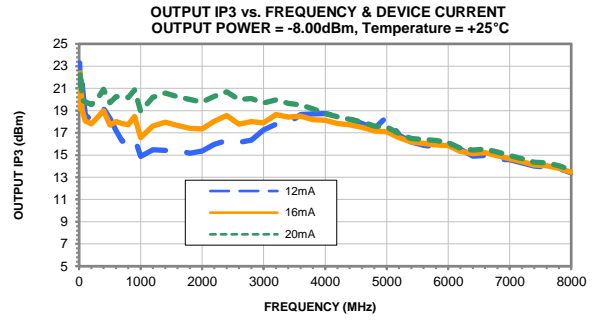
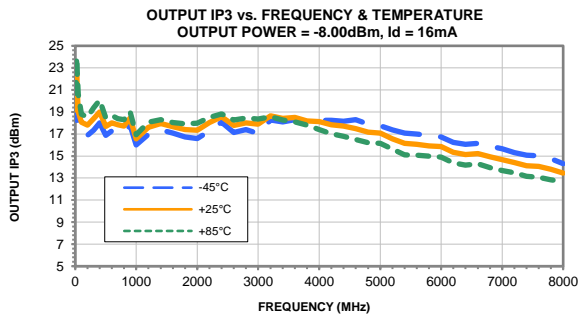

Outline Dimensions

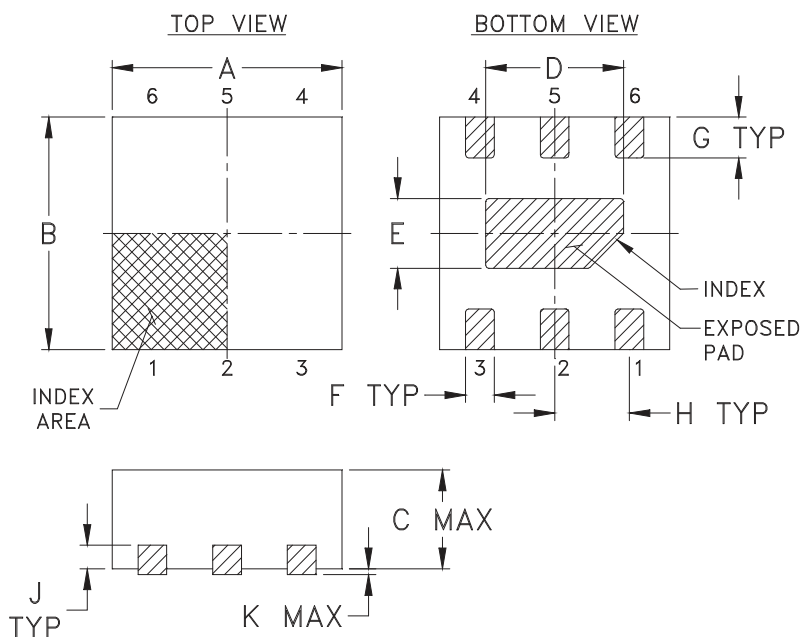

PCB Land Pattern

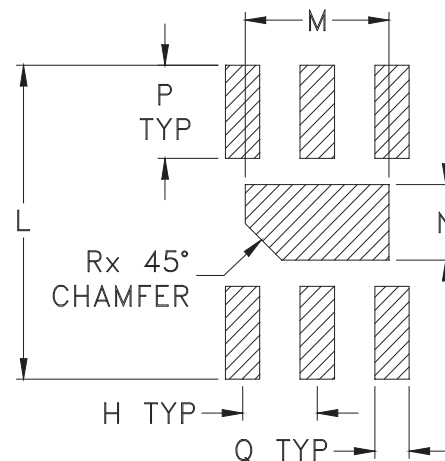

Suggested Layout,
Tolerance to be within $\pm .002$

CASE #.	A	B	C	D	E	F	G	H	J	K	L	M	N	P
MC1630-1	.079 (2.00)	.079 (2.00)	.039 (1.00)	.047 (1.20)	.024 (.60)	.010 (.25)	.014 (.35)	.026 (.65)	.008 (.20)	.002 (.05)	.106 (2.70)	.049 (1.25)	.026 (.65)	.031 (.80)

CASE #.	Q	R	WT, GRAM
MC1630-1	.012 (.30)	.012 (.30)	.006

Dimensions are in inches (mm). Tolerances: 2 Pl. $\pm .01$; 3 Pl. $\pm .005$

Notes:

- Case material: Plastic.
- Termination finish:
For RoHS Case Styles: Tin-Silver over Nickel plated or Matte-Tin plated (See Data sheet).
All models, (+) suffix.
- Lead #1 identifier shall be located in the cross-hatched area shown.
Identifier may be either a molded or marked feature.



P.O. Box 350166, Brooklyn, New York 11235-0003 (718) 934-4500 Fax (718) 332-4661 For detailed performance specs & shopping online see Mini-Circuits web site



The Design Engineers Search Engine Provides ACTUAL Data Instantly From MINI-CIRCUITS At: www.minicircuits.com

RF/IF MICROWAVE COMPONENTS

Tape & Reel Packaging TR-F66



Tape Width, mm	Device Cavity Pitch, mm	Reel Size, inches	Devices per Reel see note	
8	4	7	Small quantity standard	20
				50
				100
				200
				500
		7	Standard	1000, 2000, 3000

Note: Please consult individual model data sheet to determine device per reel availability.

Mini-Circuits carrier tape materials provide protection from ESD (Electro-Static Discharge) during handling and transportation. Tapes are static dissipative and comply with industry standards EIA-481/EIA-541.

Go to: www.minicircuits.com/pages/pdfs/tape.pdf

Mini-Circuits®

INTERNET <http://www.minicircuits.com>

P.O. Box 350166, Brooklyn, New York 11235-0003 (718) 934-4500 Fax (718) 332-4661

Distribution Centers NORTH AMERICA 800-654-7949 • 417-335-5935 • Fax 417-335-5945 • EUROPE 44-1252-832600 • Fax 44-1252-837010

Mini-Circuits ISO 9001 & ISO 14001 Certified

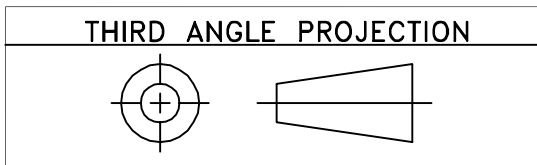

REVISIONS					
REV	ECN No.	DESCRIPTION	DATE	DR	AUTH
OR	M132574	NEW RELEASE	07/07/11	AV	DJ

SUGGESTED MOUNTING CONFIGURATION FOR MC1630 CASE STYLE, "06AF03" PIN CODE

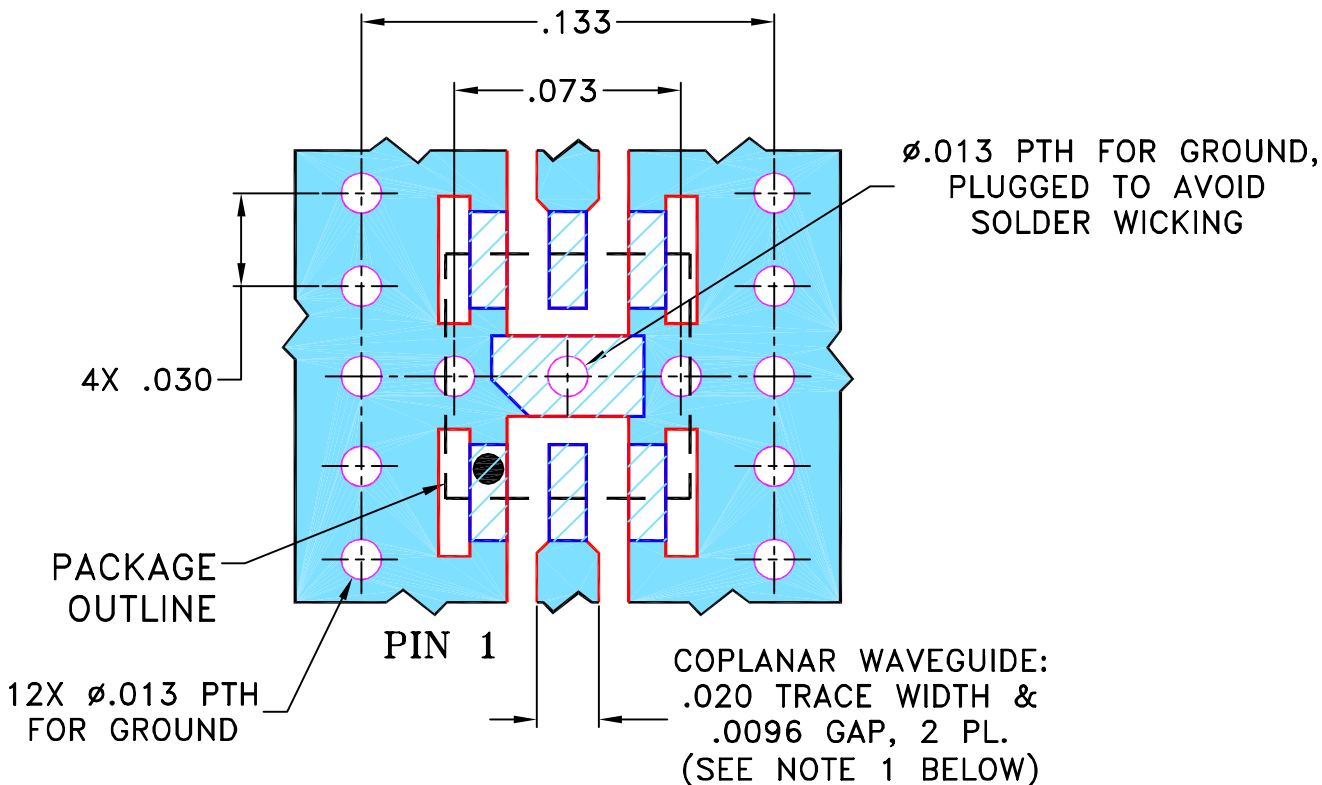

- NOTES: 1. COPLANAR WAVEGUIDE IS SHOWN FOR ROGERS R04350B WITH DIELECTRIC THICKNESS .010" ± .001"; COPPER: 1/2 OZ. EACH SIDE. FOR OTHER MATERIALS TRACE WIDTH MAY NEED TO BE MODIFIED.
 2. BOTTOM SIDE OF THE PCB IS CONTINUOUS GROUND PLANE.

- DENOTES PCB COPPER LAYOUT WITH SMOBC (SOLDER MASK OVER BARE COPPER)
 DENOTES COPPER LAND PATTERN FREE OF SOLDER MASK

UNLESS OTHERWISE SPECIFIED	INITIALS	DATE
DIMENSIONS ARE IN INCHES	DRAWN AV	06/29/11
TOLERANCES ON:	CHECKED IL	07/07/11
2 PL DECIMALS ±	APPROVED DJ	07/07/11
3 PL DECIMALS ± .005		
ANGLES ±		
FRACTIONS ±		

Mini-Circuits® 13 Neptune Avenue
Brooklyn NY 11235

PL, 06AF03, MC1630, TB-621+

Mini-Circuits®
 THIS DOCUMENT AND ITS CONTENTS ARE THE PROPERTY OF MINI-CIRCUITS. EXCEPT FOR USE EXPRESSLY GRANTED, IN WRITING, TO ITS VENDORS, VENDEE AND THE UNITED STATES GOVERNMENT, MINI-CIRCUITS RESERVES ALL PROPRIETARY DESIGN, USE, MANUFACTURING AND REPRODUCTION RIGHTS THERETO. THESE CONTENTS SHALL NOT BE USED, DUPLICATED OR DISCLOSED TO ANY OUTSIDE PARTY, IN WHOLE OR IN PART, WITHOUT WRITTEN PERMISSION OF MINI-CIRCUITS.

ASHEETA1.DWG REV:A DATE:01/12/95

SIZE	CODE IDENT	DRAWING NO:	REV:
A	15542	98-PL-349	OR
FILE:	98PL349	SCALE: 16:1	SHEET: 1 OF 1

Evaluation Board and Circuit

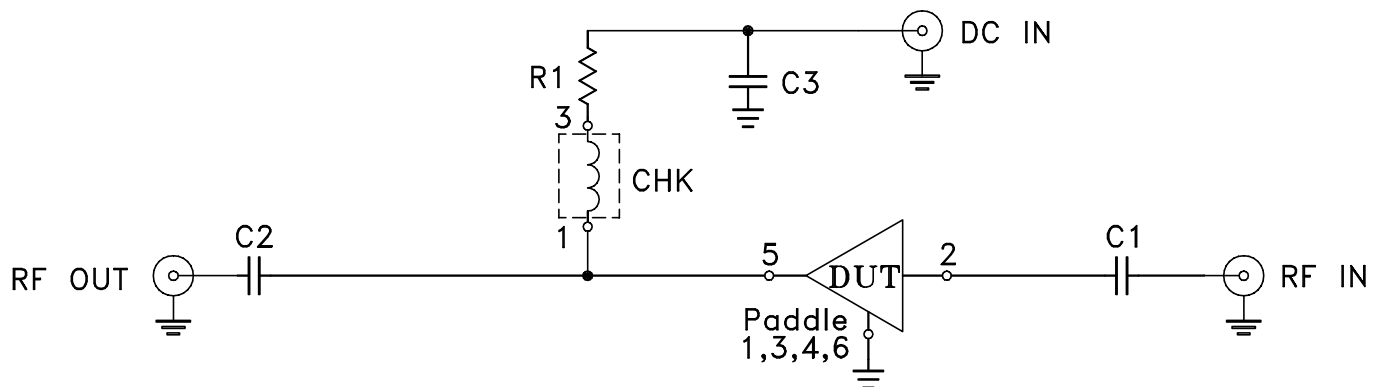
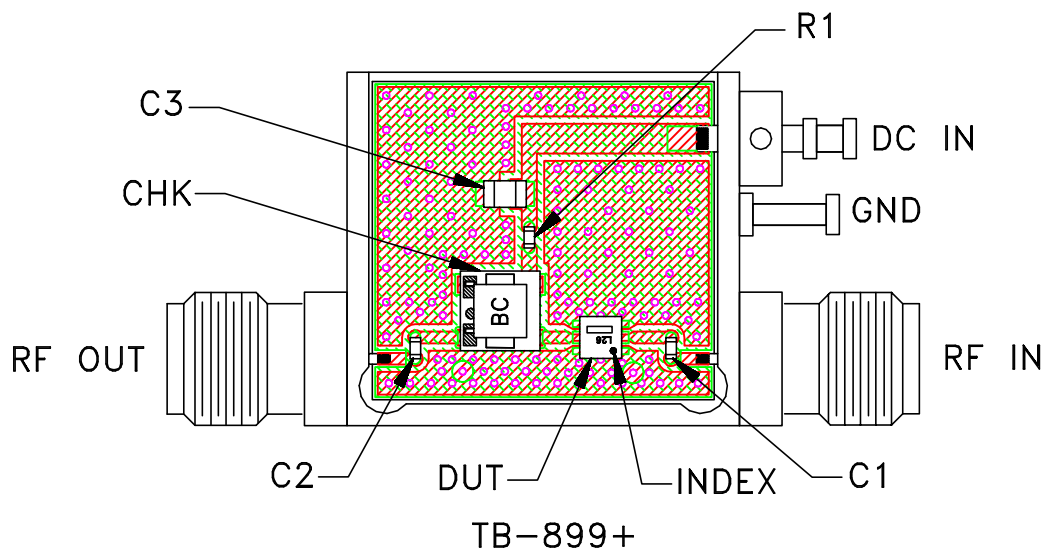

COMPONENT	VALUE	SIZE
DUT	LEE2-6+	.079"X.079"
C1,C2	0.001 uF	0402
C3	0.1 uF	0805
R1	93.1 Ohm	0402
CHK	Mini-Circuits TCCH-80+	.150"X.150"

Schematic Diagram

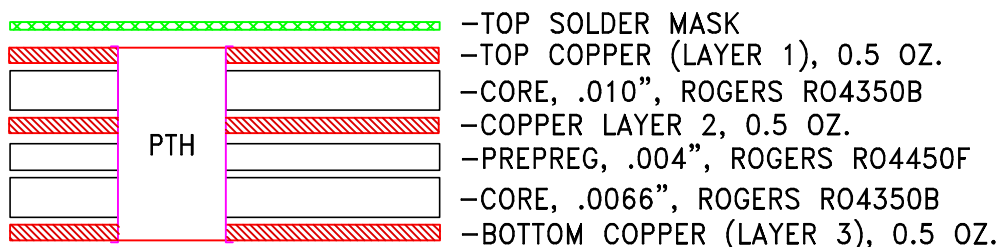

Structural Diagram

NOTES:

1. SMA Female connectors.
2. PCB material: Rogers R04350 or equivalent, dielectric constant=3.5.
Total finished thickness=.026±10% inch.

Mini-Circuits®

All Mini-Circuits products are manufactured under exacting quality assurance and control standards, and are capable of meeting published specifications after being subjected to any or all of the following physical and environmental test.

Specification	Test/Inspection Condition	Reference/Spec
Operating Temperature	-40° to 85°C Ambient Environment	Individual Model Data Sheet
Storage Temperature	-55° to 100° C or -65° to 150° Ambient Environment	Individual Model Data Sheet
Thermal Shock	-55° to 100°C, 100 cycles	MIL-STD-202, Method 107, Condition A-3, except +100°C
Mechanical Shock	1.5Kg, 0.5 ms, 5 shock pulses, Y1 direction only	MIL-STD-883, Method 2002, Condition B, except Y1 direction only
Vibration (Variable Frequency)	50g peak	MIL-STD-883, Method 2007, Condition B
Autoclave	15 psig, 100% RH, 121°C, 96 hours	JESD22-A102, Condition C
HAST	130°C, 85% RH, 96 hours	JESD22-A110
Solderability	10X Magnification	J-STD-002, Para 4.2.5, Test S, 95% Coverage
Solder Reflow Heat	Sn-Pb Eutetic Process: 240°C peak Pb-Free Process: 260°C peak	J-STD-020, Table 4-1, 4-2 and 5-2; Figure 5-1
Moisture Sensitivity: Level 1	Bake at 125°C for 24 hours Soak at 85°C/85% RH for 168 hours, Reflow 3 cycles at 260°C peak	J-STD-020
Marking Resistance to Solvents	Isopropyl alcohol + mineral spirits at 25°C; terpene defluxer at 25°C; distilled water + proylene glycol monomethyl ether +	MIL-STD-202, Method 215



All Mini-Circuits products are manufactured under exacting quality assurance and control standards, and are capable of meeting published specifications after being subjected to any or all of the following physical and environmental test.

Specification	Test/Inspection Condition	Reference/Spec
---------------	---------------------------	----------------

monoethanolamine at 63°C to 70°C