

Fast Switching SPDT RF Switch

M3SWA-2-50DRB+

Absorptive RF Switch with internal driver

The Big Deal

- High Isolation, 56 dB typ.
- High Input IP3, +46.5 dBm typ.
- Low insertion loss, 0.6 dB typ.
- Fast Rise/Fall time, 3.3 ns / 4.6 ns typ.
- Tiny Size, 3.25 x 3.25 x 0.9 mm



CASE STYLE: DL805

Product Overview

Mini-Circuits' M3SWA-2-50DRB+ is a MMIC SPDT absorptive switch with an internal driver designed for wideband operation from DC to 4.5 GHz supporting many applications requiring fast switching across a wide frequency range. This model provides excellent isolation, fast switching speed and high linearity in a tiny 3.25 x 3.25mm 8-Lead MCLP package.

Key Features

Feature	Advantages
Wideband, DC to 4.5 GHz	One model can be used in many applications, saving component count. Also ideal for wideband applications such as military and instrumentation.
Absorptive switch	In the OFF condition, RF output ports which are not switched ON are terminated into 50Ω. This enables proper impedance termination of the circuitry following the RF output ports, preventing any unintended action such as oscillation.
High Isolation: <ul style="list-style-type: none">• 62 dB at 1000 MHz• 35 dB at 4500 MHz	High isolation significantly reduces leakage of power into OFF ports.
High linearity: Input power at P1dB, 25.4 dBm typ. Input IP3, +46.5 dBm typ.	High linearity minimizes unwanted intermodulation products which are difficult or impossible to filter in multi-carrier environments such as CATV, or in the presence of strong interfering signal from adjacent circuitry or received by antenna.
Form-fit compatible with M3SWA-250DR+	Fits into existing PCB footprint designed for M3SWA-2-50DR+ with minor electrical differences.
Tiny size, 3.25 x 3.25 mm MCLP package	Tiny footprint saves space in dense layouts while providing low inductance, repeatable transitions, and excellent thermal contact to the PCB.



Fast Switching SPDT RF Switch

50Ω DC - 4500 MHz

Absorptive RF Switch with internal driver

Product Features

- High Isolation, 56 dB typ.
- Low insertion loss, 0.6 dB typ.
- Fast Rise/Fall time, 3.3 ns / 4.6 ns typ.
- High Input IP3, +46.5 dBm typ.
- Replaces M3SWA-2-50DR+

Typical Applications

- Defense
- Communication Infrastructure
- Test and Measurements

General Description

M3SWA-2-50DRB+ is a high isolation fast switching absorptive GaAs PHEMT SPDT switch with an internal driver. It operates at +5V & -5V power supplies and has a single TTL compatible control port. It has been designed for wideband operation and packaged in a tiny 3.25mm x 3.25mm, 8-lead package.

M3SWA-2-50DRB+



Generic photo used for illustration purposes only

CASE STYLE: DL805

+RoHS Compliant

The +Suffix identifies RoHS Compliance. See our web site for RoHS Compliance methodologies and qualifications

Simplified Schematic and Pad Description

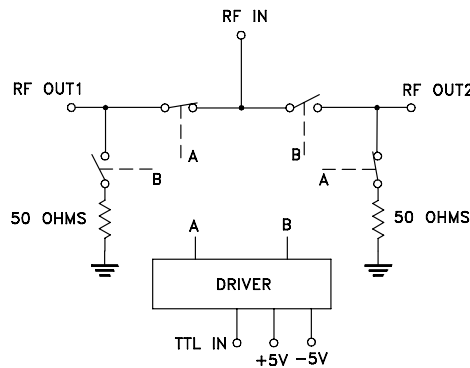

TOP VIEW

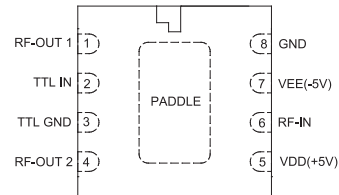

Function	Pad Number	Description
RF-IN	6	RF Common/ SUM port
RF-OUT1	1	RF Output port #1
RF-OUT2	4	RF Output port #2
TTL IN	2	TTL Compatible Control Voltage Input
TTL GND	3	TTL Ground
V _{DD} (+5V)	5	Positive Supply Voltage V _{DD}
V _{EE} (-5V)	7	Negative Supply Voltage V _{EE}
GND	8, paddle	Ground



RF Electrical Specifications¹, T_{AMB}=25°C, 50Ω, V_{DD}= +5V, V_{EE}= -5V

Parameter	Condition (MHz)	Min.	Typ.	Max.	Units
Frequency range ³		DC		4500	MHz
Insertion loss	10 - 100	—	0.5	1.0	dB
	100 - 1000	—	0.6	1.2	
	1000 - 2000	—	0.6	1.4	
	2000 - 4000	—	0.7	2.0	
	4000 - 4500	—	1.4	2.5	
Isolation between Output Port 1 & 2	10 - 100		78		dB
	100 - 1000		59		
	1000 - 2000		49		
	2000 - 4000		39		
	4000 - 4500		32		
Isolation between Common Port & Output Ports	10 - 100	65	97	—	dB
	100 - 1000	53	75	—	
	1000 - 2000	45	56	—	
	2000 - 4000	30	43	—	
	4000 - 4500	30	36	—	
Input Return loss	10 - 100		29		dB
	100 - 1000		30		
	1000 - 2000		27		
	2000 - 4000		23		
	4000 - 4500		22		
Output Return loss (Both ON STATE & OFF STATE)	10 - 100		29		dB
	100 - 1000		28		
	1000 - 2000		22		
	2000 - 4000		19		
	4000 - 4500		14		
Input Power at P1dB ²	10 - 100		19.2		dBm
	100 - 1000		24.5		
	1000 - 2000		25.4		
	2000 - 4000		25.0		
	4000 - 4500		23.8		
Input IP3 (Pout=0 dBm/Tone)	10 - 100		39.7		dBm
	100 - 1000		44.7		
	1000 - 2000		46.5		
	2000 - 4000		44.0		
	4000 - 4500		40.1		
Thermal Resistance - Junction-to-ground lead at 85°C stage temperature			34.2		°C/W

DC Electrical Specifications

Parameter	Min.	Typ.	Max.	Units
Positive Supply Voltage, V _{DD}	4.75	5	5.25	V
Negative Supply voltage, V _{EE}	-5.25	-5	-4.75	V
Positive Supply Current, I _{DD}	—	5	9	mA
Negative Supply Current, I _{EE}	-9	-3	—	mA
Control Voltage Low	—	0	0.8	V
Control Voltage High	2.1	2.3	5	V
Control Current Low	—	0	0.2	mA
Control Current High	—	0.4	5	mA

Notes:

1. Tested on Mini-Circuits' test board TB-M3SWA250DRB+ (See Fig.1)
2. Input Power at P1dB compression drops to 13 dB at 10 MHz.
3. All RF-ports must be DC blocked or held at 0V DC.

Switching Specifications

Parameter	Condition	Min.	Typ.	Max.	Units
ON Time, 50% control to 90% RF	RF Pin= 0 dBm RF Freq.= 500 MHz Control Freq.= 500 KHz Control High= 2.3V Control Low= 0V		14.4		ns
OFF Time, 50% control to 10% RF			11.3		ns
Video Leakage			42.5		mV
Rise Time, 10% RF to 90% RF			3.3		ns
Fall Time, 90% RF to 10% RF			4.6		ns



Absolute Maximum Ratings⁴

Parameter	Ratings
Operating temperature	-55°C to +100°C
Storage temperature	-55°C to +100°C
RF Input power	+24 dBm
Junction Temperature	134°C
Total Power Dissipation	0.4W
DC Voltage, Pin 5	+6V
DC Voltage, Pin 7	-6V

4. Permanent damage may occur if any of these limits are exceeded. Electrical Maximum ratings are not intended for continuous normal operation.

Truth Table

State of Control Voltage	RF-IN to RF-OUT1	RF-IN to RF-OUT 2
LOW	ON	OFF
HIGH	OFF	ON

Characterization & Application Circuit

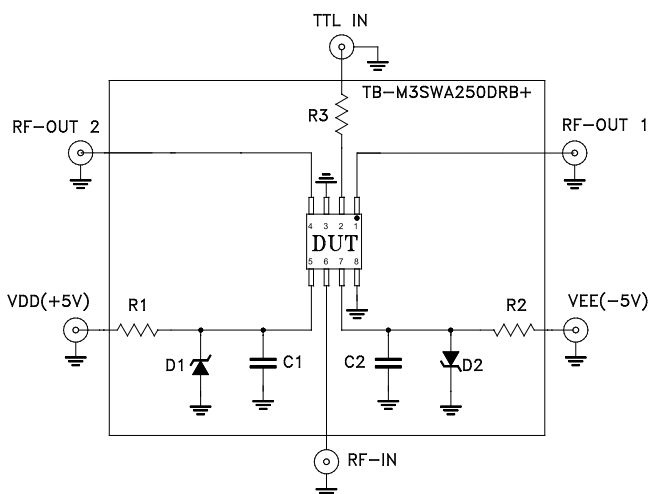

Component	Size	Value	P/N	Manufacturer
DUT	3.25x3.25	N/A	M3SWA-2-50DRB+	MCL
D1, D2	SOD-123	Vz = 5.6V	MMSZ4690T1G	ON Semiconductor
R1, R2	0603	11.5Ω	RK73H1JTTD11R5F	KOA
R3	0603	100Ω	RK73H1JTTD1000F	KOA
C1, C2	0603	10pF	06031A100GAT2A	AVX

Note: D1&D2 are optional.

Figure 1. Characterization & Application Circuit

Note: (DUT soldered on Mini-Circuits Characterization & Application Test Board TB-M3SWA250DRB+).

Insertion Loss, Amplitude Unbalance, Isolation, Return Loss, Input Power at 1dB Compression (P1dB) & Input IP3 tested using E5071C microwave network analyzer.

Condition:

1. Insertion Loss, Amplitude Unbalance, Isolation & Return Loss: Pin = 0dBm
2. Input IP3(IIP3): Two tones, spaced 1 MHz apart, 0dBm/tone output.

Product Marking

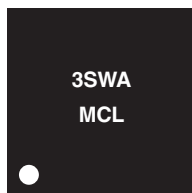

Marking may contain other features or characters for internal lot control

Additional Detailed Technical Information

additional information is available on our dash board.

Performance Data	Data Table
	Swept Graphs
Case Style	DL805 <i>Plastic package, exposed paddle, lead finish=Matte-Tin</i>
Tape & Reel Standard quantities available on reel	F58 <i>7" reels with 1000 devices 13" reels with 2000, 4000 devices</i>
Suggested Layout for PCB Design	PL-120
Evaluation Board	TB-M3SWA250DRB+
Environmental Ratings	ENV16

ESD Rating

Human Body Model (HBM): Class 0 (Pass 100V) in accordance with ESD STM5.1-2001

MSL Rating

Moisture Sensitivity: MSL1 in accordance with IPC/JEDEC J-STD-020D

MSL Test Flow Chart

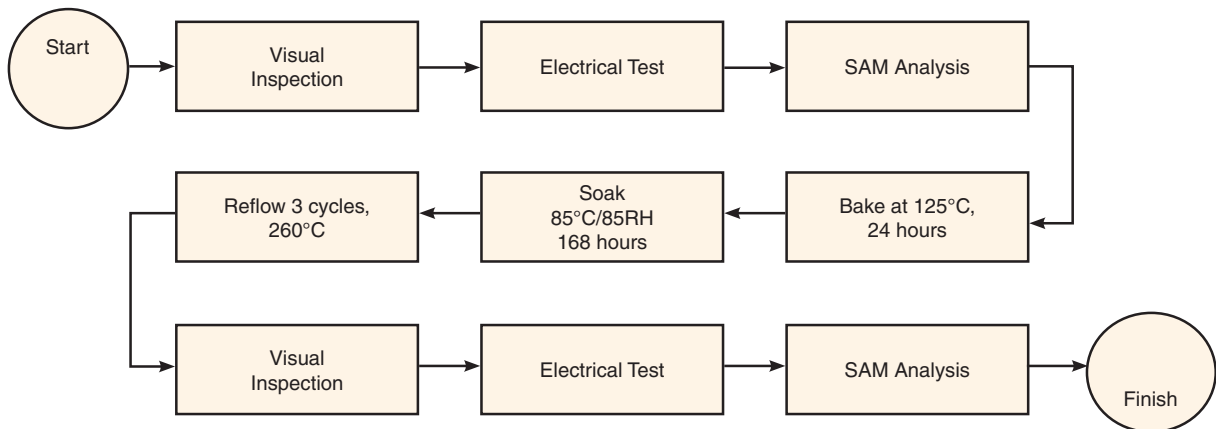

Additional Notes

- A. Performance and quality attributes and conditions not expressly stated in this specification document are intended to be excluded and do not form a part of this specification document.
- B. Electrical specifications and performance data contained in this specification document are based on Mini-Circuit's applicable established test performance criteria and measurement instructions.
- C. The parts covered by this specification document are subject to Mini-Circuits standard limited warranty and terms and conditions (collectively, "Standard Terms"); Purchasers of this part are entitled to the rights and benefits contained therein. For a full statement of the Standard Terms and the exclusive rights and remedies thereunder, please visit Mini-Circuits' website at www.minicircuits.com/MCLStore/terms.jsp

Typical Performance Data

FREQ (MHz)	INSERTION LOSS @ VDD=+5V, VEE =-5V OVER TEMPERATURE						FREQ (MHz)	ISOLATION @ VDD=+5V, VEE =-5V OVER TEMPERATURE											
	RF COM-RF1 (dB) STATE 2*			RF COM-RF2 (dB) STATE 1*				RF COM-RF1 (dB) STATE 1*			RF COM-RF2 (dB) STATE 2*			RF1-RF2 (dB) STATE 2*			RF1-RF2 (dB) STATE 1*		
	-55°C	+25°C	+100°C	-55°C	+25°C	+100°C		-55°C	+25°C	+100°C	-55°C	+25°C	+100°C	-55°C	+25°C	+100°C	-55°C	+25°C	+100°C
	10	0.56	0.40	0.41	0.57	0.40		0.41	10	75.71	73.96	74.25	69.98	74.07	72.97	68.02	74.12	78.54	68.70
50	0.65	0.48	0.47	0.66	0.49	0.48	50	76.31	78.78	77.76	83.80	76.09	73.96	69.13	71.43	80.91	70.26	76.64	70.17
100	0.66	0.49	0.48	0.67	0.49	0.49	100	78.97	99.21	93.28	81.82	86.50	95.03	68.32	72.48	72.31	71.25	71.97	71.59
200	0.67	0.51	0.51	0.69	0.52	0.51	200	80.72	84.70	82.41	78.69	84.18	83.86	63.20	65.96	66.80	65.74	66.49	66.75
400	0.67	0.52	0.53	0.69	0.53	0.53	400	82.88	81.71	76.90	76.18	81.67	74.51	59.16	60.25	60.87	60.20	61.12	61.33
600	0.66	0.53	0.55	0.68	0.53	0.55	600	81.12	74.49	70.31	83.57	71.78	70.34	56.42	57.37	58.12	56.74	57.92	58.24
800	0.66	0.53	0.57	0.67	0.53	0.56	800	75.64	69.23	66.80	71.97	66.18	64.99	53.97	55.57	55.72	54.24	55.16	55.30
1000	0.65	0.53	0.57	0.66	0.53	0.57	1000	67.14	64.86	63.49	65.73	63.62	62.42	52.43	53.39	53.23	52.51	53.13	53.12
1100	0.65	0.53	0.58	0.66	0.54	0.58	1100	64.33	62.91	61.75	63.20	61.65	60.56	51.57	52.38	52.16	51.47	52.34	52.17
1200	0.65	0.54	0.59	0.66	0.54	0.58	1200	61.96	61.01	59.79	61.68	60.77	59.13	50.93	51.57	51.35	50.59	51.39	51.23
1300	0.65	0.54	0.60	0.66	0.54	0.59	1300	60.53	59.94	58.74	59.67	58.69	57.75	49.93	50.86	50.55	49.70	50.53	50.40
1400	0.65	0.55	0.60	0.66	0.54	0.59	1400	58.81	58.39	57.30	58.09	57.27	56.95	49.31	50.01	49.67	48.93	49.69	49.45
1500	0.65	0.55	0.60	0.65	0.55	0.60	1500	57.41	56.97	56.35	56.75	56.01	55.87	48.38	49.09	48.91	48.07	49.03	48.74
1600	0.65	0.55	0.61	0.66	0.55	0.61	1600	55.62	55.60	55.04	55.31	54.98	54.44	47.54	48.45	48.08	47.26	48.14	47.87
1700	0.65	0.55	0.62	0.66	0.55	0.61	1700	54.35	54.60	53.80	54.14	53.80	53.28	46.99	47.76	47.46	46.59	47.50	47.30
1800	0.65	0.56	0.62	0.66	0.56	0.62	1800	54.25	53.71	53.29	53.65	52.82	52.35	46.43	46.96	46.76	45.95	46.81	46.45
1900	0.65	0.56	0.63	0.66	0.56	0.62	1900	52.30	52.57	51.72	51.40	51.72	50.95	45.39	46.40	45.84	44.92	46.05	45.60
2000	0.65	0.57	0.63	0.66	0.57	0.63	2000	51.15	51.47	50.62	50.49	50.49	50.19	44.60	45.74	45.27	44.19	45.37	45.01
2100	0.65	0.57	0.64	0.67	0.57	0.64	2100	50.13	50.41	49.91	49.56	49.75	49.37	43.83	44.83	44.49	43.24	44.58	44.17
2200	0.65	0.57	0.65	0.67	0.58	0.65	2200	49.11	49.60	49.07	48.74	48.90	48.63	43.58	44.24	44.23	43.02	43.97	43.88
2300	0.65	0.58	0.66	0.66	0.58	0.65	2300	48.00	48.73	48.20	47.72	47.98	47.74	42.45	43.71	43.18	41.98	43.36	42.87
2400	0.66	0.59	0.68	0.67	0.58	0.66	2400	47.10	47.79	47.21	46.67	46.98	46.55	42.22	43.32	43.25	41.61	42.89	42.80
2500	0.65	0.59	0.68	0.67	0.59	0.67	2500	46.36	46.80	46.73	45.88	46.22	45.69	41.41	42.45	42.15	40.78	42.04	41.53
2600	0.65	0.59	0.68	0.67	0.59	0.68	2600	45.65	46.34	45.88	45.16	45.53	45.12	40.53	41.90	41.40	39.99	41.49	41.09
2800	0.66	0.60	0.71	0.67	0.60	0.70	2800	44.13	44.86	44.42	43.64	44.25	43.79	39.26	40.56	40.22	38.76	40.17	39.88
3000	0.66	0.62	0.73	0.68	0.62	0.73	3000	42.97	43.80	43.28	42.85	43.20	42.97	37.95	39.29	38.79	37.42	38.88	38.51
3200	0.69	0.65	0.77	0.69	0.65	0.77	3200	41.52	42.57	42.09	41.38	41.90	41.45	36.94	38.28	37.91	36.37	37.84	37.49
3400	0.70	0.67	0.81	0.71	0.68	0.81	3400	41.00	41.62	40.99	40.44	40.93	40.50	35.77	37.08	36.77	35.11	36.56	36.25
3600	0.75	0.73	0.87	0.77	0.75	0.89	3600	40.55	41.18	40.55	39.62	39.93	39.40	34.60	35.97	35.54	33.69	35.12	34.72
3800	0.81	0.80	0.96	0.84	0.83	0.98	3800	39.46	40.02	39.63	38.27	38.66	38.25	33.71	34.96	34.54	32.54	34.03	33.63
4000	0.94	0.96	1.13	0.98	1.01	1.16	4000	39.15	39.50	39.20	37.32	37.77	37.29	32.72	33.83	33.38	31.52	32.90	32.36
4200	1.18	1.19	1.35	1.23	1.29	1.45	4200	37.87	38.25	37.81	36.54	36.98	36.38	31.67	32.68	32.31	30.42	31.76	31.46
4400	1.43	1.45	1.63	1.50	1.59	1.77	4400	37.00	37.51	36.73	35.39	35.88	35.51	30.55	31.63	31.19	29.22	30.80	30.59
4500	1.77	1.72	1.89	1.90	1.90	2.06	4500	37.29	37.18	37.06	35.03	35.57	35.41	30.07	30.93	30.58	28.86	30.43	30.09
5000	1.56	1.55	1.76	1.75	1.67	1.86	5000	32.57	33.21	32.72	32.41	33.18	32.90	27.89	28.53	28.10	27.92	29.02	28.53
5200	1.40	1.43	1.68	1.49	1.46	1.71	5200	31.90	32.24	32.08	31.79	32.27	32.05	27.15	27.76	27.40	27.26	28.23	27.85

STATE	CONTROL INPUT	RF Com to RF1	RF Com to RF2
1	High	OFF	ON
2	Low	ON	OFF



Typical Performance Data

FREQ (MHz)	RETURN LOSS @ Vdd=+5V OVER TEMPERATURE																	
	RF COM (dB)			RF COM (dB)			RF1 (dB)			RF1 (dB)			RF2 (dB)			RF2 (dB)		
	STATE 2*			STATE 1*			STATE 2*			STATE 1*			STATE 2*			STATE 1*		
	-55°C	+25°C	+100°C	-55°C	+25°C	+100°C	-55°C	+25°C	+100°C	-55°C	+25°C	+100°C	-55°C	+25°C	+100°C	-55°C	+25°C	+100°C
10	25.84	28.99	28.65	25.52	29.15	28.85	26.07	29.36	29.14	28.66	38.25	36.61	28.82	37.96	36.18	25.76	29.44	29.28
50	27.58	30.89	30.39	27.07	31.19	30.66	26.91	30.49	29.94	28.97	37.30	35.50	28.80	37.33	35.30	26.60	30.54	30.02
100	27.60	30.64	29.69	26.94	30.34	29.40	26.69	30.19	29.97	28.94	36.77	34.59	28.89	36.96	34.36	26.33	30.14	30.02
200	27.19	30.02	28.86	26.56	29.68	28.46	26.22	29.49	29.74	28.75	37.00	33.82	28.74	36.86	33.48	25.90	29.55	29.96
400	26.95	30.18	29.76	26.09	29.74	29.45	25.55	28.32	28.70	29.29	37.11	34.65	30.07	36.01	34.19	25.88	28.78	28.96
600	27.24	30.77	31.43	26.79	30.45	30.60	25.08	27.31	27.15	30.40	36.62	36.52	31.16	34.75	34.50	25.50	28.16	28.04
800	28.61	31.72	31.32	28.11	32.06	31.62	24.53	26.47	25.81	30.14	36.45	37.06	31.30	33.57	33.28	25.24	27.79	27.34
1000	29.52	31.28	32.44	29.68	33.66	35.47	23.46	25.01	24.46	29.48	37.47	36.00	30.86	33.20	32.69	24.67	26.43	25.37
1100	29.39	30.04	30.47	30.76	33.05	33.14	23.12	24.30	23.16	29.26	38.57	38.72	30.01	33.10	34.18	24.38	25.79	24.10
1200	29.12	28.60	28.00	31.91	31.93	31.04	22.56	23.60	22.19	28.61	40.11	46.05	28.77	32.98	35.34	23.69	25.13	23.58
1300	28.25	27.22	26.81	32.18	30.78	31.04	21.80	22.94	21.99	27.87	42.23	47.57	27.80	32.72	33.78	22.87	24.41	23.69
1400	27.03	26.17	26.91	31.37	29.34	31.14	21.23	22.45	22.32	27.71	44.55	41.03	27.29	32.74	32.33	22.21	23.64	23.44
1500	26.13	25.40	27.06	30.65	28.05	29.66	20.92	22.06	22.36	27.96	46.43	40.07	26.79	32.94	32.14	21.71	22.90	22.57
1600	25.79	24.79	26.15	29.95	26.91	27.72	20.76	21.72	21.73	28.11	47.40	43.24	26.03	33.14	33.40	21.08	22.18	21.67
1700	25.56	24.22	24.82	28.69	25.92	26.64	20.41	21.31	20.98	27.74	50.80	69.71	25.36	33.49	35.70	20.38	21.53	21.31
1800	24.95	23.68	24.10	27.41	25.05	26.42	19.92	20.89	20.69	27.25	54.88	42.99	24.95	34.07	36.65	19.78	20.92	21.25
1900	23.96	23.21	24.15	26.29	24.32	26.24	19.42	20.52	20.88	26.98	47.63	37.83	24.87	35.36	36.20	19.29	20.41	21.11
2000	23.20	22.84	24.57	25.53	23.89	25.79	19.07	20.26	21.16	27.22	41.79	36.15	24.94	37.17	35.43	18.96	20.13	20.79
2100	22.88	22.66	24.67	24.97	23.65	25.16	18.94	20.14	21.13	27.99	37.94	36.37	25.26	39.21	35.77	18.73	19.99	20.32
2200	22.90	22.67	24.37	24.62	23.51	24.74	19.01	20.21	20.87	29.48	35.31	36.47	25.72	40.90	37.33	18.60	19.82	19.91
2300	23.20	23.00	24.37	24.26	23.30	24.60	19.16	20.40	20.67	31.25	33.35	35.14	26.01	43.40	40.80	18.41	19.66	19.72
2400	23.35	23.27	24.68	23.98	23.19	24.85	19.44	20.70	20.95	33.15	32.20	32.69	26.30	49.78	42.85	18.19	19.54	19.95
2500	23.73	23.73	25.64	23.77	23.22	25.16	19.51	21.00	21.54	34.27	31.26	30.58	26.88	52.08	37.77	18.07	19.58	20.29
2600	24.04	24.14	26.45	24.05	23.36	25.20	19.43	21.15	22.12	35.11	30.65	29.28	28.20	43.73	35.22	18.20	19.68	20.31
2800	25.31	25.07	26.70	24.98	23.53	24.16	20.01	21.61	22.21	42.59	29.09	28.75	31.42	36.91	38.53	18.83	19.83	19.44
3000	26.57	25.45	26.29	24.96	23.71	24.35	20.90	21.97	21.79	33.48	27.45	27.71	31.86	32.40	31.34	18.82	20.07	20.23
3200	26.11	25.58	26.03	25.04	23.27	23.05	20.25	21.96	21.98	31.11	26.27	25.33	32.04	30.07	28.83	19.13	19.86	19.29
3400	25.58	24.31	23.77	23.84	22.51	22.21	20.39	21.05	19.90	28.76	25.66	25.72	28.71	28.11	29.44	18.86	19.41	18.57
3600	23.59	22.83	22.74	22.48	21.59	21.77	19.21	19.67	18.87	25.81	25.64	26.20	26.50	26.30	24.92	17.90	18.45	18.25
3800	21.91	21.51	21.66	20.91	20.29	20.13	17.85	18.54	18.08	26.44	25.48	24.45	25.14	25.47	24.90	17.01	17.28	16.30
4000	21.35	21.06	21.19	19.77	19.62	19.89	17.09	17.01	16.23	25.48	25.66	26.04	23.59	24.53	24.35	15.60	15.69	15.53
4200	21.99	23.06	23.47	20.29	21.03	20.56	15.42	15.98	16.07	24.47	25.33	25.02	23.52	24.28	22.56	14.30	14.26	13.93
4400	21.95	23.51	24.46	20.28	21.05	21.14	14.36	14.73	14.66	25.95	24.69	23.29	22.92	23.65	23.53	13.35	12.95	12.71
4500	28.53	30.51	29.14	25.02	25.05	24.24	13.78	13.98	13.77	25.20	24.69	23.90	21.99	23.26	23.16	12.20	12.08	12.20
5000	17.26	16.68	16.23	14.89	14.73	14.70	13.81	13.57	13.24	22.32	21.51	20.35	20.00	21.42	21.07	10.97	11.30	11.43
5200	13.86	13.65	13.88	12.27	12.21	12.38	13.37	13.28	13.28	19.88	20.56	20.49	20.05	20.81	19.13	11.16	11.28	10.93

*Note:

STATE	CONTROL INPUT	RF Com to RF1	RF Com to RF2
1	High	OFF	ON
2	Low	ON	OFF



Typical Performance Curves

Insertion Loss @ VDD=+5V, VEE =-5V over Temperature
RF COM-RF1 (State 2*) & RF COM-RF2 (State 1*)

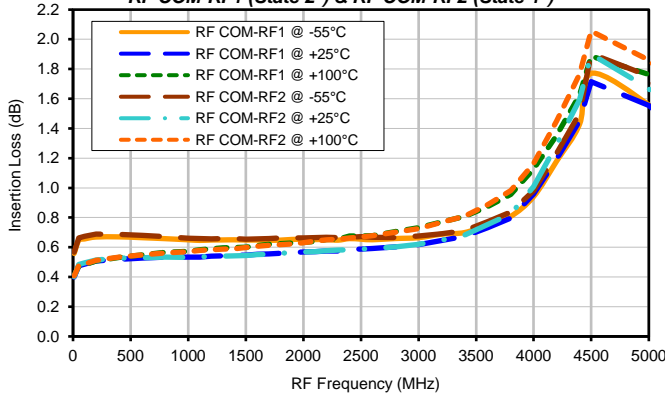

Isolation @ VDD=+5V, VEE =-5V over Temperature
RF COM-RF1 (State 1*) & RF COM-RF2 (State 2*)

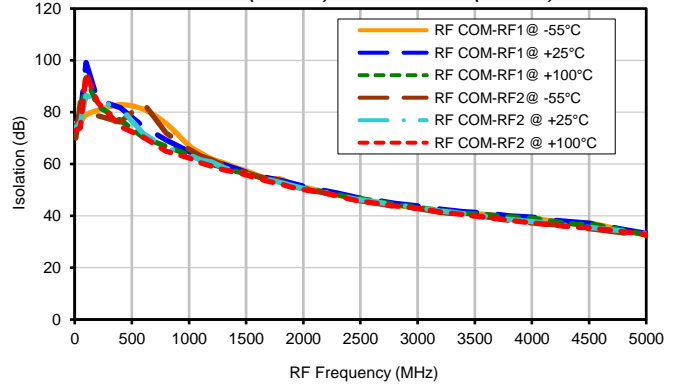

Isolation @ VDD=+5V, VEE =-5V over Temperature
RF1-RF2 (State 1*)

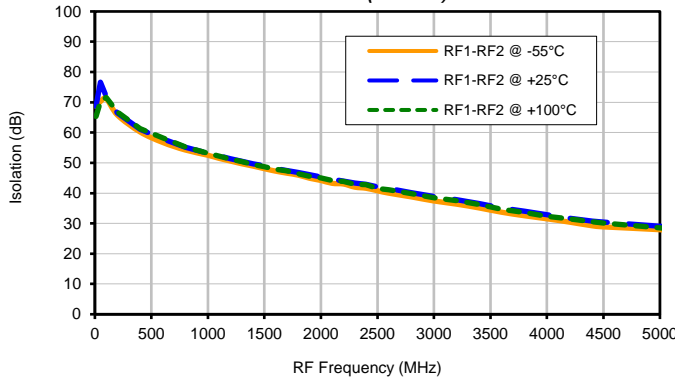

Isolation @ VDD=+5V, VEE =-5V over Temperature
RF1-RF2 (State 2*)

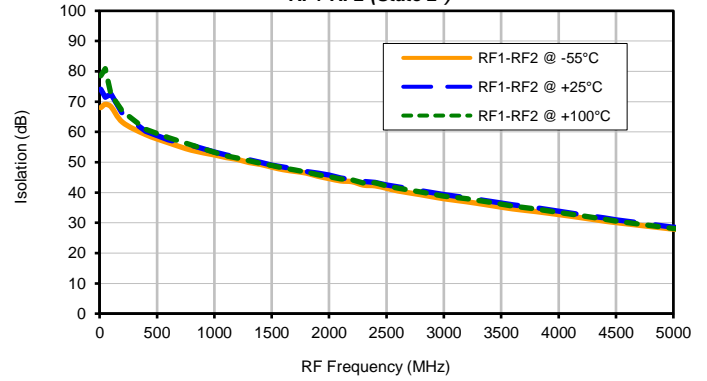

RL @ VDD=+5V, VEE =-5V over Temperature
RF COM (State 1*)

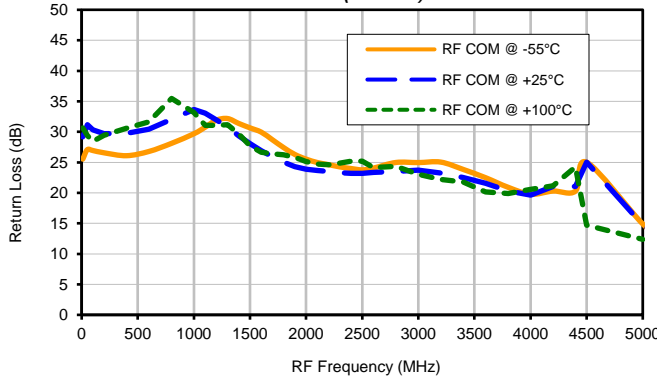

RL @ VDD=+5V, VEE =-5V over Temperature
RF COM (State 2*)

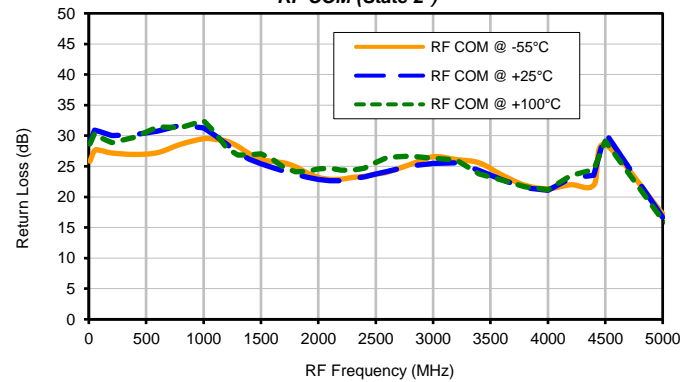

*Note:

STATE	CONTROL INPUT	RF Com to RF1	RF Com to RF2
1	High	OFF	ON
2	Low	ON	OFF

Typical Performance Curves

RL @ VDD=+5V, VEE =-5V over Temperature
RF1 (State 2*)

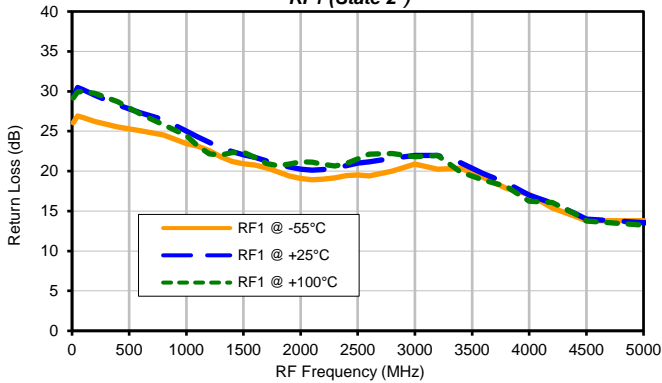

RL @ VDD=+5V, VEE =-5V over Temperature
RF1 (State 1*)

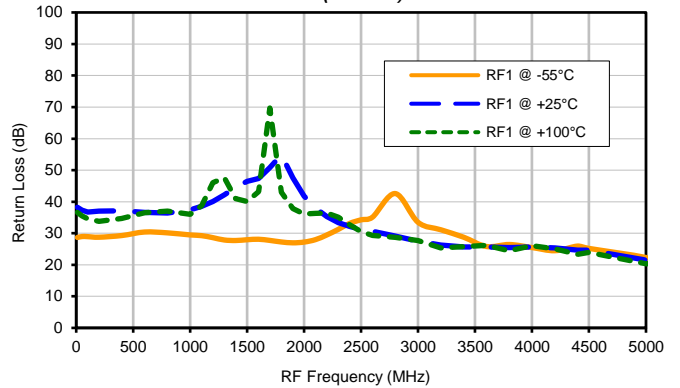

RL @ VDD=+5V, VEE =-5V over Temperature
RF2 (State 1*)

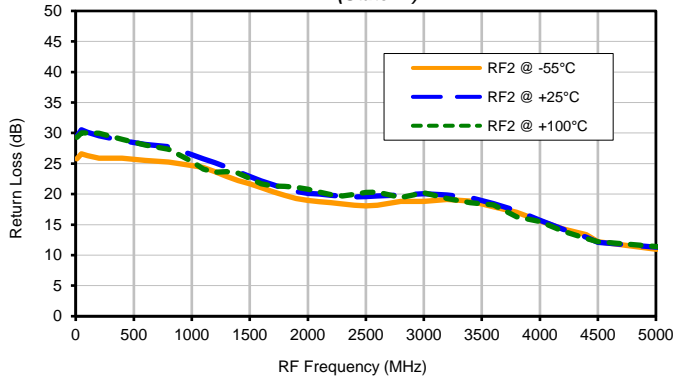

RL @ VDD=+5V, VEE =-5V over Temperature
RF2 (State 2*)

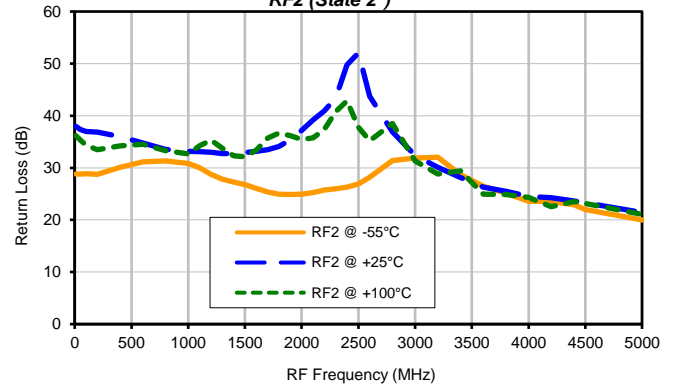

*Note:

STATE	CONTROL INPUT	RF Com to RF1	RF Com to RF2
1	High	OFF	ON
2	Low	ON	OFF

Outline Dimensions

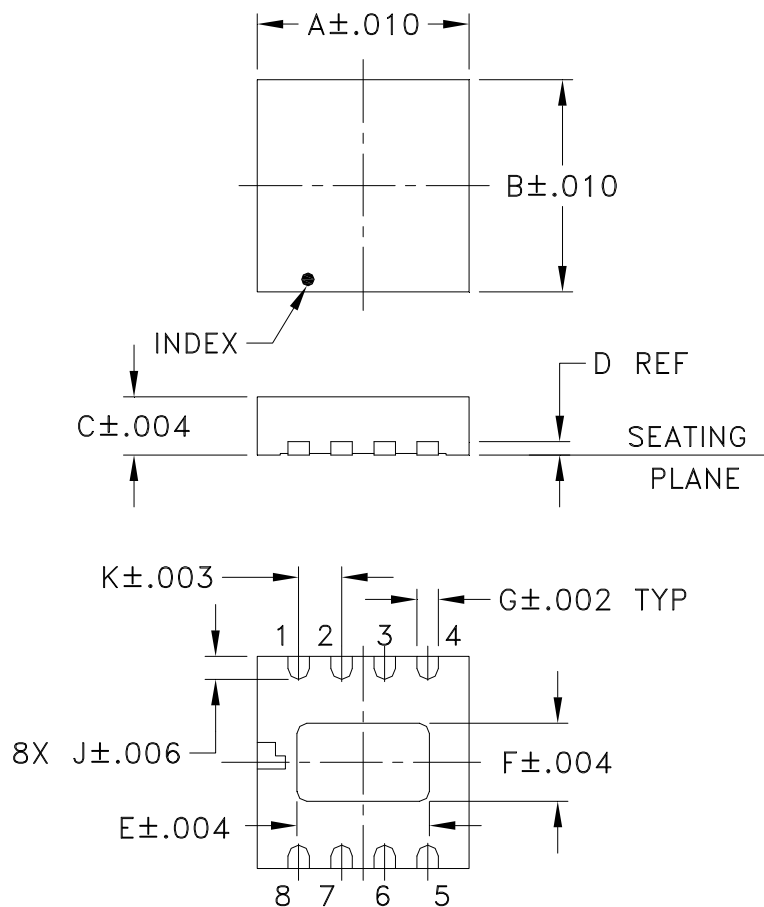

PCB Land Pattern

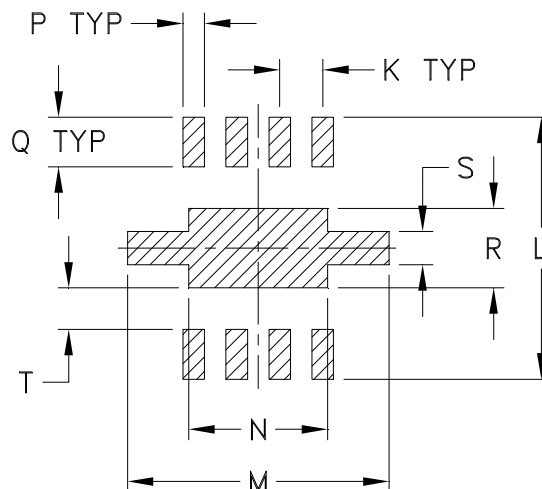

Suggested Layout,
Tolerance to be within $\pm.002$

CASE #	A	B	C	D	E	F	G	H	J	K	L	M	N
DL805	.128 (3.25)	.128 (3.25)	.035 (0.90)	.008 (0.20)	.080 (2.03)	.047 (1.19)	.013 (0.33)	-- --	.014 (0.36)	.026 (0.66)	.158 (4.01)	.158 (4.01)	.084 (2.13)

CASE #	P	Q	R	S	T	WT. GRAM
DL805	.013 (0.33)	.030 (0.76)	.048 (1.22)	.020 (0.51)	.025 (0.64)	.02

Dimensions are in inches (mm). Tolerances: 2 Pl. $\pm.01$; 3Pl. $\pm.004$

Notes:

1. Case material: Plastic.
2. Termination finish:

For RoHS Case Styles: Tin-Silver alloy plate over Nickel barrier or Matte-Tin. All models, (+) suffix.
See model data sheet.

For RoHS-5 Case Styles: Tin-Lead plate. All models, no (+) suffix.



P.O. Box 350166, Brooklyn, New York 11235-0003 (718) 934-4500 Fax (718) 332-4661 For detailed performance specs & shopping online see Mini-Circuits web site



The Design Engineers Search Engine Provides ACTUAL Data Instantly From MINI-CIRCUITS At: www.minicircuits.com

RF/IF MICROWAVE COMPONENTS

Tape & Reel Packaging TR-F58

DEVICE ORIENTATION IN T&R

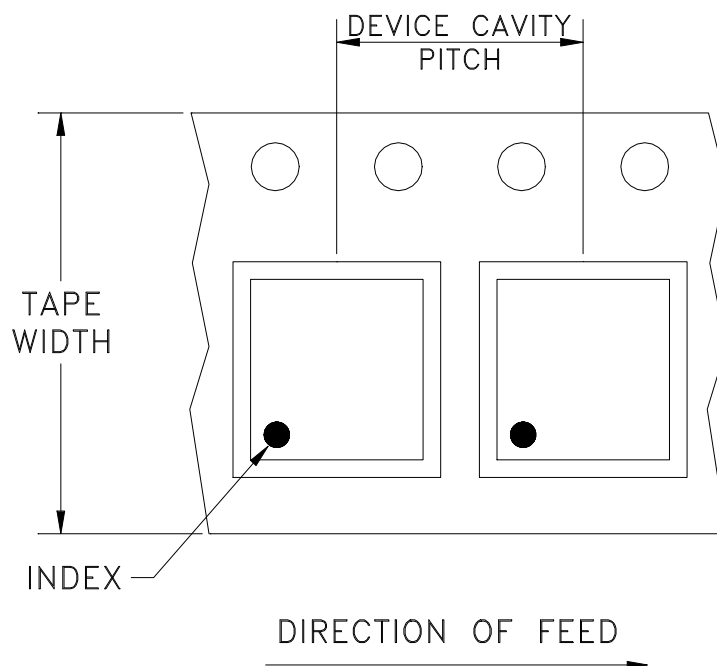

Tape Width, mm	Device Cavity Pitch, mm	Reel Size, inches	Devices per Reel
12	8	7	1000
		13	2000, 4000

Mini-Circuits carrier tape materials provide protection from ESD (Electro-Static Discharge) during handling and transportation. Tapes are static dissipative and comply with industry standards EIA-481/EIA-541.

Go to: www.minicircuits.com/pages/pdfs/tape.pdf



INTERNET <http://www.minicircuits.com>

P.O. Box 350166, Brooklyn, New York 11235-0003 (718) 934-4500 Fax (718) 332-4661

Distribution Centers NORTH AMERICA 800-654-7949 • 417-335-5935 • Fax 417-335-5945 • EUROPE 44-1252-832600 • Fax 44-1252-837010

Mini-Circuits ISO 9001 & ISO 14001 Certified

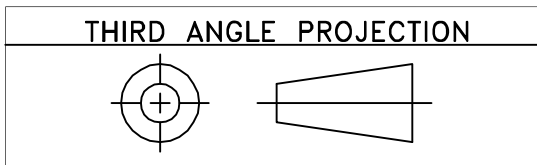

REVISIONS					
REV	ECN No.	DESCRIPTION	DATE	DR	AUTH
OR	M82940	NEW RELEASE	11/15/02	MMG	MM
A	M91639	REMOVED NOTE 2	04/14/04	AV	DJ
B	M102713	CHNG DESCRIPTION, ADDED "...WITH SMOBC"	01/16/06	GF	IL
C	M175851	UPDATED DESCRIPTION INFORMATION	08/09/19	CA	IL

**SUGGESTED MOUNTING CONFIGURATION
FOR DL805 CASE STYLE, "08SW06" PIN CONNECTION.**

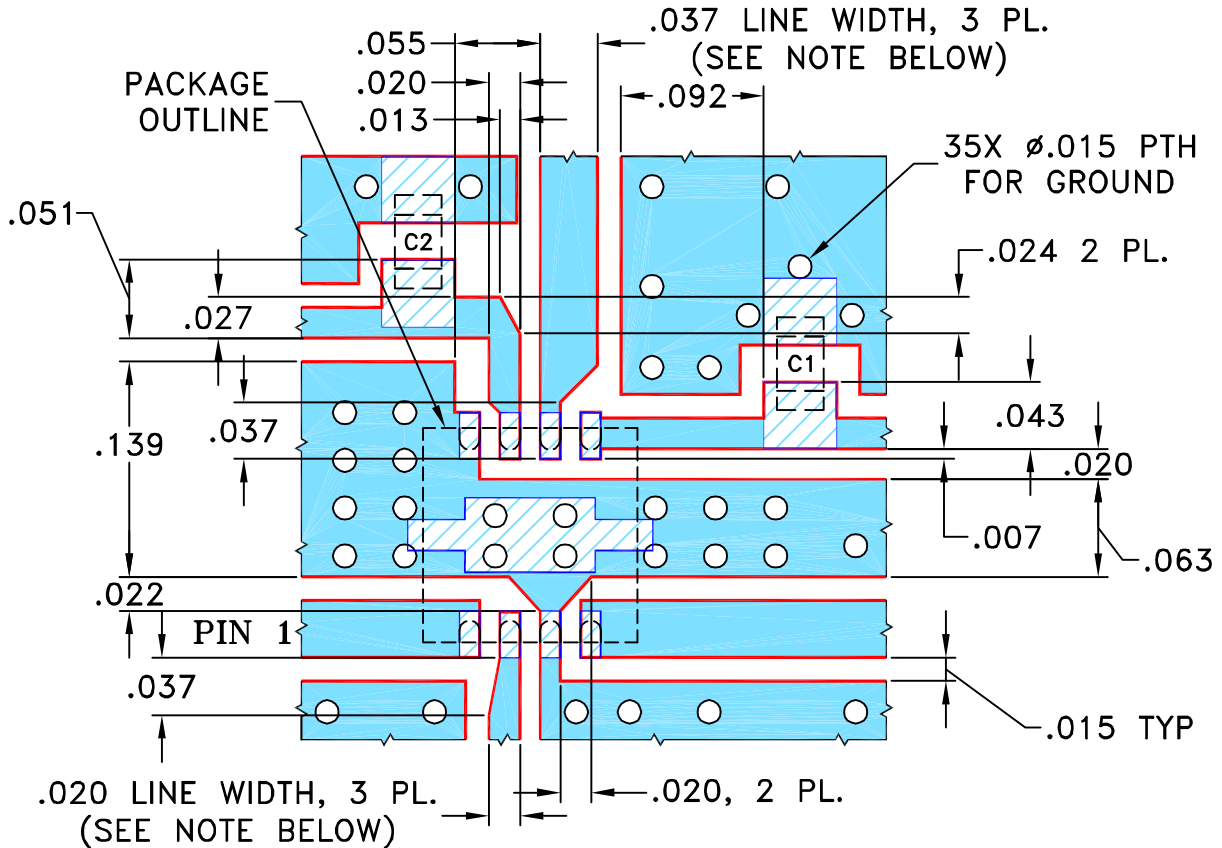

CAPACITORS C1 & C2: 0603 SIZE.

- NOTES: 1. TRACE WIDTH IS SHOWN FOR ROGERS R04350B WITH DIELECTRIC THICKNESS 0.020" ± 0.0015"; COPPER: 1/2 OZ. EACH SIDE. FOR OTHER MATERIALS TRACE WIDTH MAY NEED TO BE MODIFIED.
2. CHIP COMPONENTS FOOT PRINTS SHOWN FOR REFERENCE, FOR COMPONENT VALUES REFER TO TB-M3SW-250DRA+/TB-M3SWA250DRB+.
3. BOTTOM SIDE OF THE PCB IS CONTINUOUS GROUND PLANE.

- DENOTES PCB COPPER LAYOUT WITH SMOBC (SOLDER MASK OVER BARE COPPER)
- DENOTES COPPER LAND PATTERN FREE OF SOLDER MASK

UNLESS OTHERWISE SPECIFIED	INITIALS	DATE
DIMENSIONS ARE IN INCHES	DRAWN MMG	11/13/02
TOLERANCES ON:	CHECKED AV	11/15/02
2 PL DECIMALS ±	APPROVED MM	11/15/02
3 PL DECIMALS ± .005		
ANGLES ± 1°		
FRACTIONS ±		

Mini-Circuits® 13 Neptune Avenue
Brooklyn NY 11235

PL, DL805, TB-M3SW-250DRA+/TB-M3SWA250DRB+

SIZE A	CODE IDENT 15542	DRAWING NO: 98-PL-120	REV: C
FILE: 98PL120	SCALE: 8:1	SHEET: 1 OF 1	

Mini-Circuits®
 THIS DOCUMENT AND ITS CONTENTS ARE THE PROPERTY OF MINI-CIRCUITS. EXCEPT FOR USE EXPRESSLY GRANTED, IN WRITING, TO ITS VENDORS, VENDEE AND THE UNITED STATES GOVERNMENT, MINI-CIRCUITS RESERVES ALL PROPRIETARY DESIGN, USE, MANUFACTURING AND REPRODUCTION RIGHTS THERETO. THESE CONTENTS SHALL NOT BE USED, DUPLICATED OR DISCLOSED TO ANY OUTSIDE PARTY, IN WHOLE OR IN PART, WITHOUT WRITTEN PERMISSION OF MINI-CIRCUITS.

Evaluation Board and Circuit

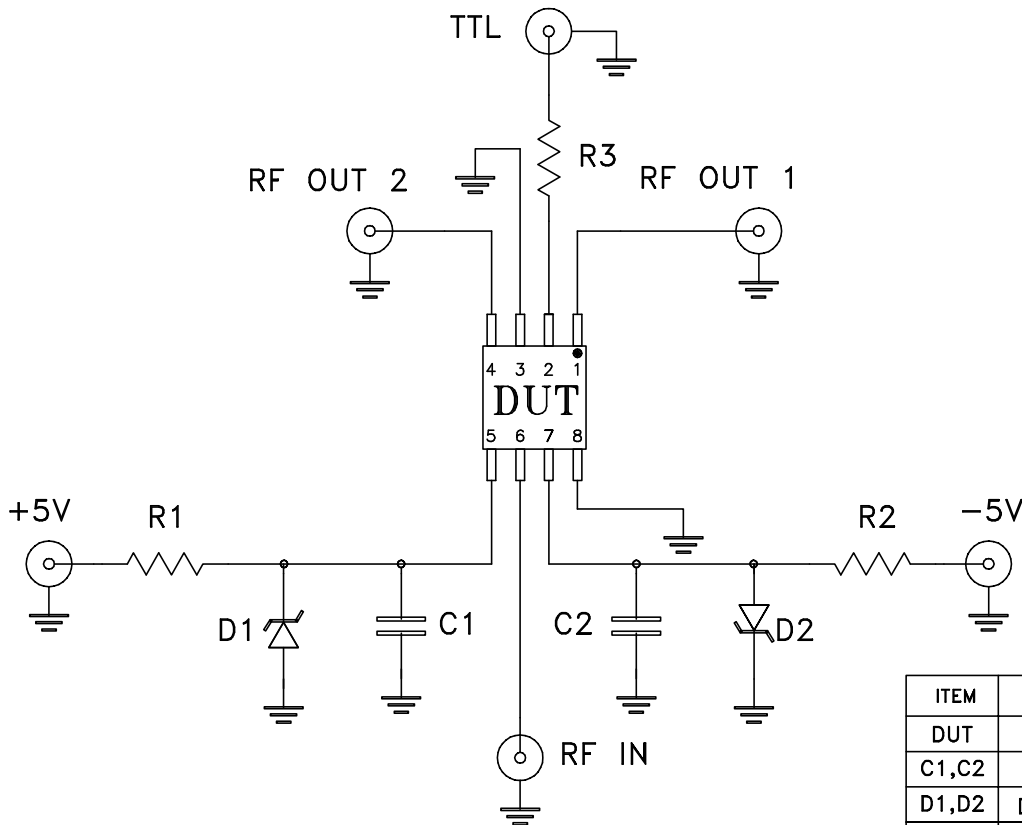
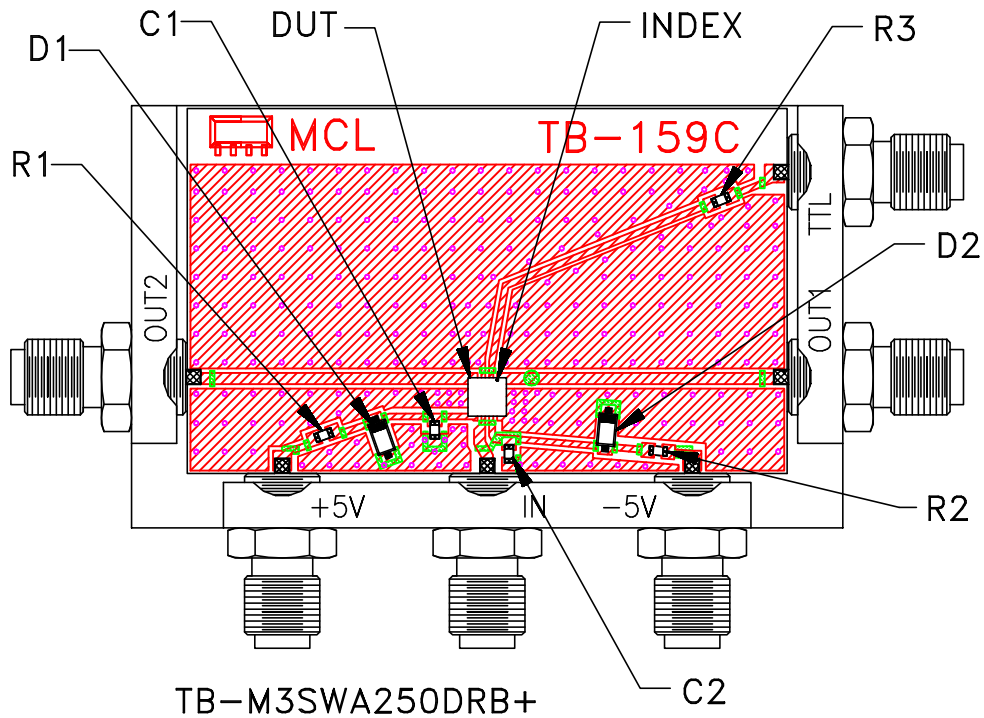

Schematic Diagram

ITEM	DESCRIPTION	SIZE
DUT	MCL SWITCH	3.25X3.25 MM
C1,C2	Capacitor 10 pF	0603
D1,D2	Diod Zener 5.6V	SOT-123
R1,R2	Resistor 11.5 Ohm	0603
R3	Resistor 100 Ohm	

Notes:

1. SMA Female connectors.
2. PCB Material: Rogers R04350 or equivalent, Dielectric Constant=3.5, Thickness=.020 inch.
3. TB name "TB-159C" marked on PCB may be ignored. The correct TB name is TB-M3SWA250DRB+.

 **Mini-Circuits®**

All Mini-Circuits products are manufactured under exacting quality assurance and control standards, and are capable of meeting published specifications after being subjected to any or all of the following physical and environmental test.

Specification	Test/Inspection Condition	Reference/Spec
Operating Temperature	-55° to 100°C Ambient Environment	Individual Model Data Sheet
Storage Temperature	-55° to 100° C Ambient Environment	Individual Model Data Sheet
Temperature Cycling	-55° to 100°C, 100 cycles	MIL-STD-883, Method 1010, Condition B, except 100°C
Solder Reflow Profile	Sn-Pb Eutetic Process: 240°C peak PB-Free Process: 250°C peak	J-STD-020, table 4-1,4-2 and 5-2; figure 5-1
Vibration (Variable Frequency)	50g peak	MIL-STD-883, Method 2007, Condition B
Mechanical Shock	1.5Kg, 0.5 ms, 5 shock pulses, Y1 direction only	MIL-STD-883, Method 2002, Condition B, except Y1 direction only
Moisture Sensitivity: Level 1	Bake at 125°C for 24 hours. Soak at 85°C/85%RH for 168 hours Reflow 3 cycles at 260°C peak	J-STD-020
Marking Resistance to Solvents	Isopropyl alcohol + mineral spirits at 25°C; terpene defluxer at 25°C; distilled water + proylene glycol monomethyl ether + monoethanolamine at 63°C to 70°C	MIL-STD-202, Method 215