

### Product Overview

The SXA389Z is a high efficiency GaAs Heterojunction Bipolar Transistor (HBT) MMIC amplifier housed in low-cost surface-mountable plastic package. These HBT MMICs are fabricated by using molecular beam epitaxial growth technology which produces reliable and consistent performance from wafer to wafer and lot to lot. These amplifiers are specially designed for use as driver devices for infrastructure equipment in the 400 MHz to 2500 MHz of cellular, ISM, WLL, PCS and W-CDMA applications.

The SXA389Z's internal active bias circuitry allows the amplifier to operate directly from a 5V supply and provides stable current over temperature.



SOT-89 Package

### Key Features

- On Chip Active Bias Control
- Single Supply, 5V Operation
- High Output IP3, +42 to +44dBm Typ.
- High Output P1dB, +25dB, Typ.
- High Gain, +19dB at 850 MHz
- High Efficiency, only 600 mW Consumption
- Patented High Reliability GaAs HBT Technology
- Surface Mountable Power Plastic Package

### Functional Block Diagram

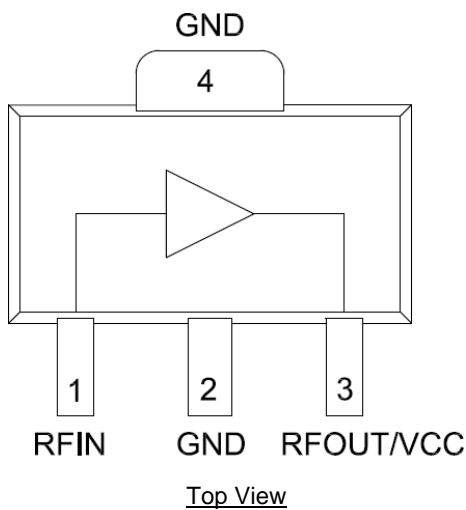

### Applications

- W-CDMA, PCS, Cellular Systems
- High Linearity IF Amplifiers
- Multi-Carrier Applications

### Ordering Information

Part No.	Description
SXA389ZTR7	1,000 pieces on a 7" reel
SXA389Z EVB-3	2140 MHz Evaluation Board

## Absolute Maximum Ratings

Parameter	Rating
Maximum Storage Temperature	+150 °C
Device Voltage (V <sub>CC</sub> )	+6.0 V
Device Current (I <sub>CC</sub> )	240 mA
RF Input Power	100 mW
Maximum Power Dissipation	1500 mW
Junction Temperature (T <sub>J</sub> )	+165 °C

Exceeding any one or a combination of the Absolute Maximum Rating conditions may cause permanent damage to the device. Extended application of Absolute Maximum Rating conditions to the device may reduce device reliability.

## Electrical Specifications

Parameter	Conditions <sup>(1)</sup>	Min	Typ	Max	Units
Gain, Small Signal	850 MHz		19.0		dB
	1960 MHz		14.0		dB
	2140 MHz	12.5	13.5	15.0	dB
	2450 MHz		13.0		dB
Input VSWR	850 MHz		1.3:1		-
	1960 MHz		1.4:1		-
	2140 MHz		1.3:1		-
	2450 MHz		1.1:1		-
Output P1dB	850 MHz		25.0		dBm
	1960 MHz		25.0		dBm
	2140 MHz	24.0	25.0		dBm
	2450 MHz		25.0		dBm
Output IP3 <sup>(2)</sup>	850 MHz		43.0		dBm
	1960 MHz		44.0		dBm
	2140 MHz	39.0	42.0		dBm
	2450 MHz		42.0		dBm
Noise Figure	850 MHz		4.7		dB
	1960 MHz		5.5		dB
	2140 MHz		6.0		dB
	2450 MHz		6.0		dB
Device Operating Current, I <sub>CC</sub>	Pin 3	90	115	122	mA
Operating Power Dissipation			575	610	mW
Thermal Resistance, θ <sub>Jc</sub>	Junction to backside		100		°C/W

Notes:

1. Test conditions unless otherwise noted: V<sub>CC</sub> = +5.0 V, Temp = +25 °C, 50 Ω test system
2. P<sub>OUT</sub> = 11 dBm/tone, Δf = 1 MHz

## Recommended Operating Conditions

Parameter	Min	Typ	Max	Units
Device Voltage (V <sub>CC</sub> )		+5		V
T <sub>CASE</sub>	-40		+85	°C

Electrical specifications are measured at specified test conditions. Specifications are not guaranteed over all recommended operating conditions.

## 2140MHz Evaluation Board – SXA389ZEV3

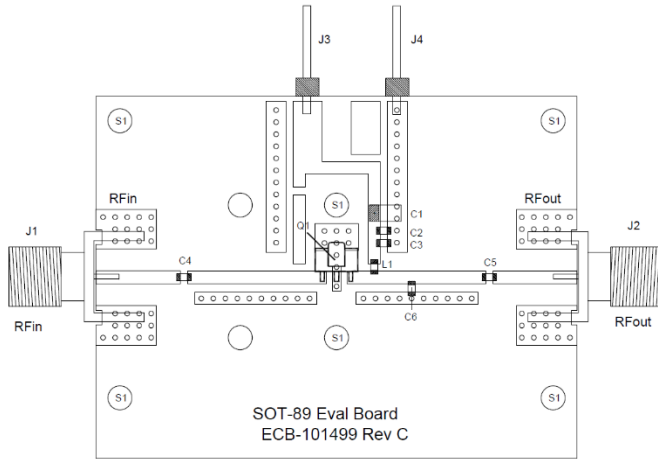

Transmission Line Electrical Lengths  
EL1=31.4° @ 2140 MHz

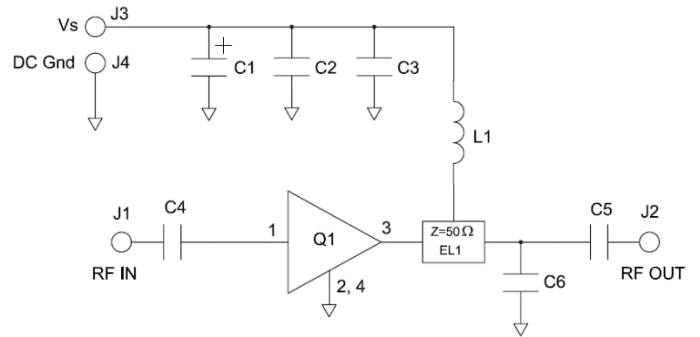

## Bill of Material – SXA389ZEV3

Reference Des.	Value	Description	Manuf.	Part Number
PCB	-	Printed Circuit Board	Qorvo	268409
Q1	-	AMP, GaAs HBT, SOT-89	Qorvo	SXA389Z
C1	0.1 $\mu$ F	CAP, 0.1 $\mu$ F, 20%, 35V, TANT-A	AVX	TAJA104M035R
C2	1000 pF	CAP, 1000 pF, 10%, 50V, X7R, 0603	Murata	GRM188R71H102KA01D
C3, C4, C5	22 pF	CAP, 22 pF, 5%, 50V, NPO, 0603	Murata	GRM1885C1H220JA01D
C6	0.5 pF	CAP, 0.5 pF, $\pm$ 0.1 pF, 50V, C0G, 0603	Murata	GRM1885C1HR50BA01D
L1	18 nH	IND, 18 nH, 5%, 600mA, M/L, 0603	Murata	LQG18HN18NJ00D
J1, J2	-	CONN, SMA, END LAUNCH, 0.031"	Cinch	142-0701-881

## Transmission Line Electrical Length – SXA389ZEV3

Reference Des.	Value	Description
EL1	31.4°	Electrical length at 2140 MHz between Q1 Pin 3 and C6

2140MHz Performance Plots – SXA389ZEV3

Test conditions unless otherwise noted:  $V_{CC} = +5V$ ,  $I_C = 120mA$ , Optimized for OIP3, 50  $\Omega$  test system, Temp.=+25 °C

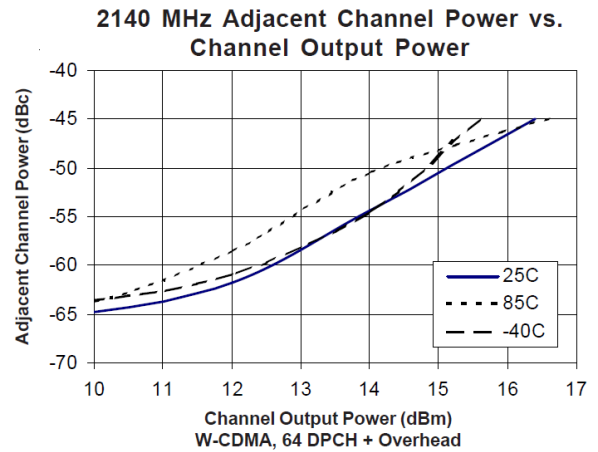
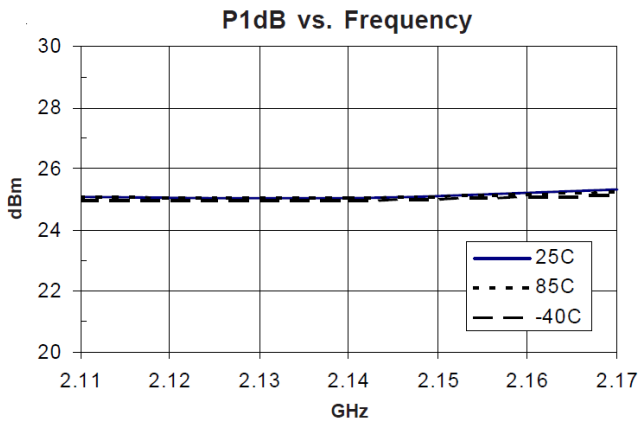
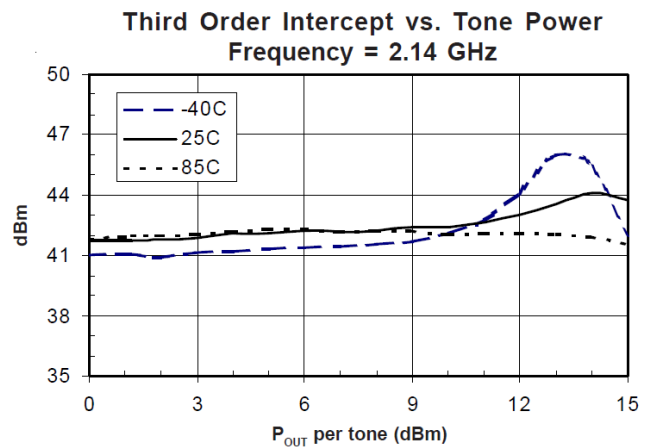
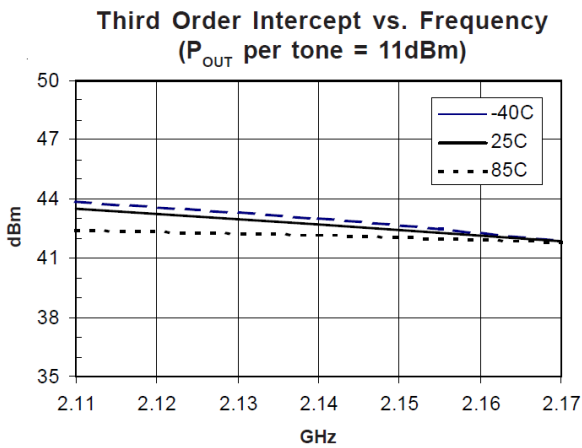
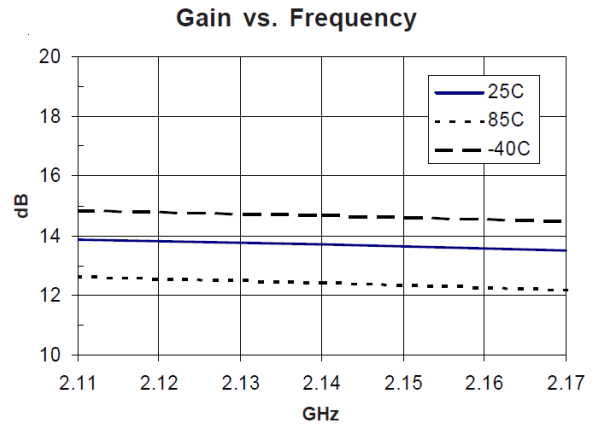
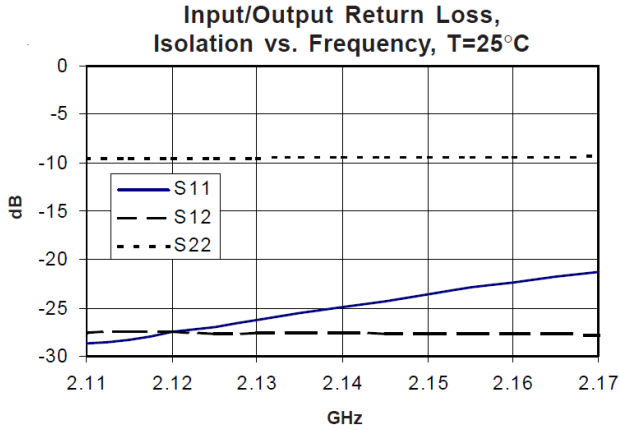

## 850MHz Application Reference

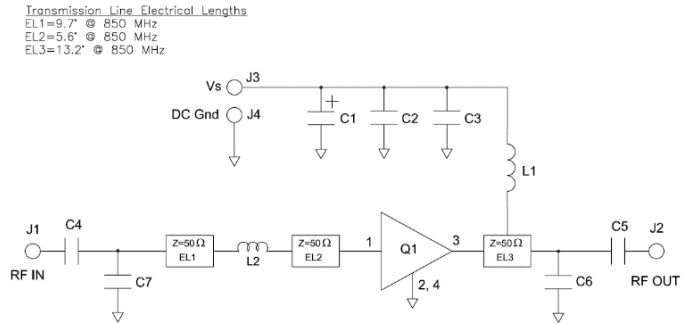
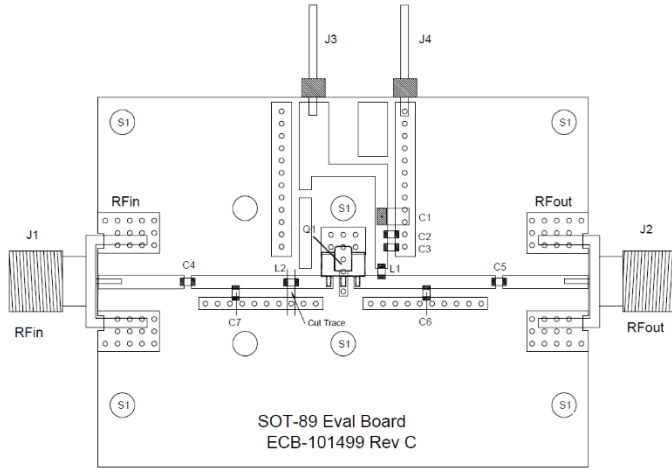

## Bill of Material – 850MHz Application Reference

Reference Des.	Value	Description	Manuf.	Part Number
PCB	-	Printed Circuit Board	Qorvo	268409
Q1	-	AMP, GaAs HBT, SOT-89	Qorvo	SXA389Z
C1	0.1 $\mu$ F	CAP, 0.1 $\mu$ F, 20%, 35V, TANT-A	AVX	TAJA104M035R
C2	1000 pF	CAP, 1000 pF, 10%, 50V, X7R, 0603	Murata	GRM188R71H102KA01D
C3, C4, C5	47 pF	CAP, 47 pF, 5%, 50V, C0G, 0603	Murata	GRM1885C1H470JA01D
C6, C7	3.9 pF	CAP, 3.9 pF, $\pm$ 0.1 pF, 50V, C0G, 0603	Murata	GRM1885C1H3R9BA01D
L1	33 nH	IND, 33 nH, 5%, 500mA, M/L, 0603	Murata	LQG18HN33NJ00D
L2	1.2 nH	IND, 1.2 nH, $\pm$ 0.3 nH, 1000mA, M/L, 0603	Murata	LQG18HN1N2S00D
J1, J2	-	CONN, SMA, END LAUNCH, 0.031"	Cinch	142-0701-881

## Transmission Line Electrical Length – 850 MHz Application Reference

Reference Des.	Value	Description
EL1	9.7°	Electrical length at 850 MHz, Between C5 and L2
EL2	5.6°	Electrical length at 850 MHz, Between L2 and U1 Pin 1
EL3	13.2°	Electrical length at 850 MHz, Between U1 Pin 3 and C6

## Performance Plots – 850MHz Application Reference

Test conditions unless otherwise noted:  $V_{CC} = +5V$ ,  $I_C = 120mA$ , Optimized for OIP3, 50  $\Omega$  test system, Temp.=+25 °C

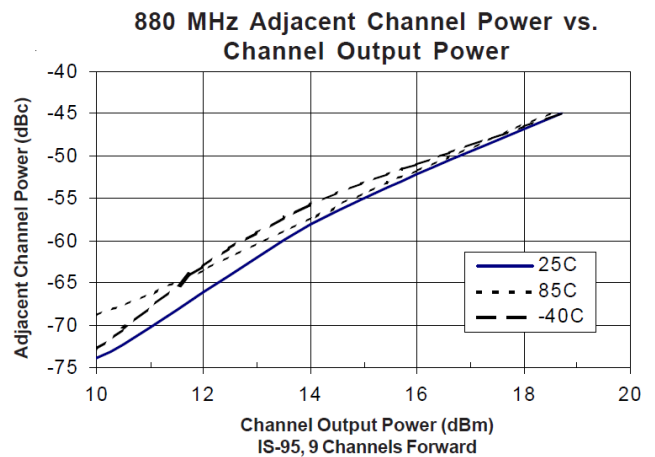
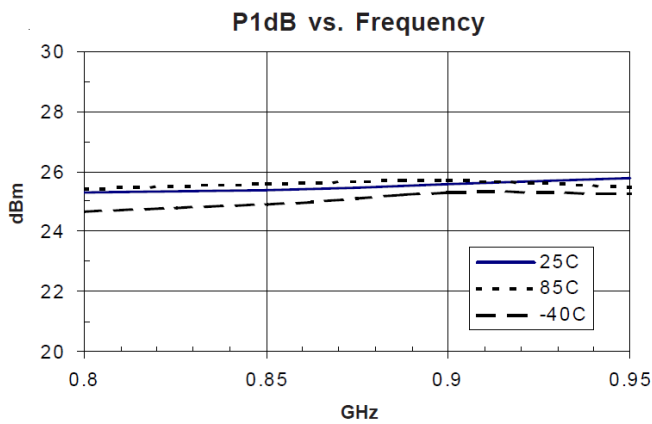
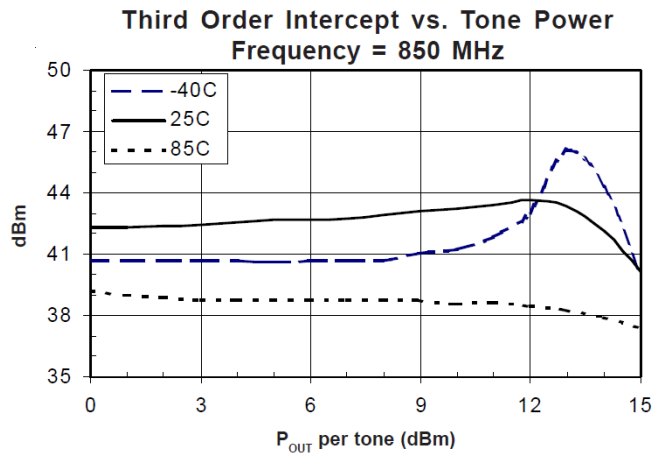
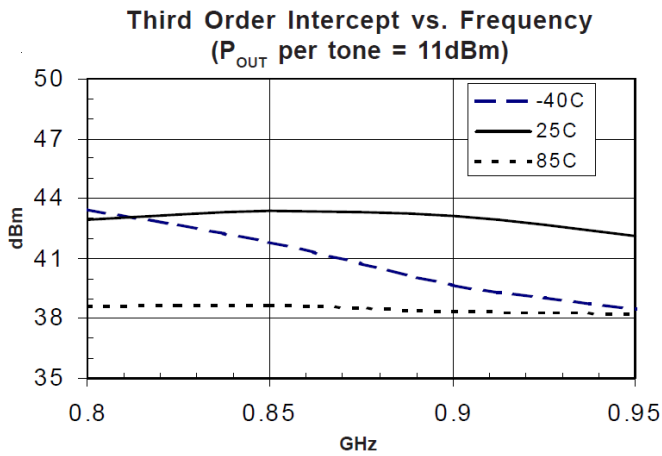
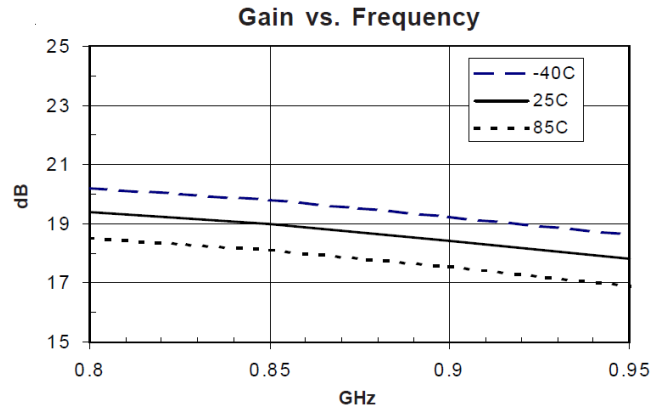
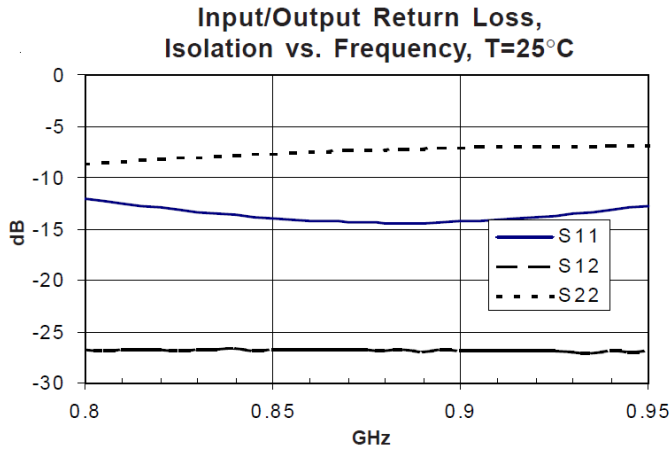

## 1960MHz MHz Application Reference

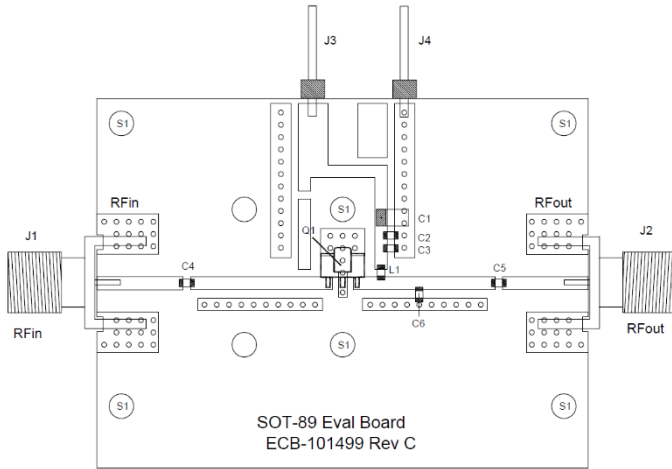

Transmission Line Electrical Lengths  
EL1=28.7° @ 1960 MHz

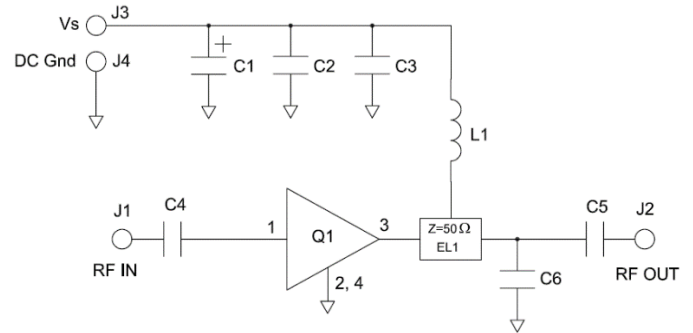

## Bill of Material – 1960MHz Application Reference

Reference Des.	Value	Description	Manuf.	Part Number
PCB	-	Printed Circuit Board	Qorvo	268409
Q1	-	AMP, GaAs HBT, SOT-89	Qorvo	SXA389Z
C1	0.1 $\mu$ F	CAP, 0.1 $\mu$ F, 20%, 35V, TANT-A	AVX	TAJA104M035R
C2	1000 pF	CAP, 1000 pF, 10%, 50V, X7R, 0603	Murata	GRM188R71H102KA01D
C3, C4, C5	22 pF	CAP, 22 pF, 5%, 50V, NPO, 0603	Murata	GRM1885C1H470JA01D
C6	0.5 pF	CAP, 0.5 pF, $\pm$ 0.1 pF, 50V, C0G, 0603	Murata	GRM1885C1H3R9BA01D
L1	18 nH	IND, 18 nH, 5%, 600mA, M/L, 0603	Murata	LQG18HN18NJ00D
J1, J2	-	CONN, SMA, END LAUNCH, 0.031"	Cinch	142-0701-881

## Transmission Line Electrical Length – 1960MHz Application Reference

Reference Des.	Value	Description
EL1	28.7°	At 1960 MHz Between Q1 Pin 3 and C6

## 1960MHz Performance Plots – Application Reference

Test conditions unless otherwise noted:  $V_{CC} = +5V$ ,  $I_C = 120mA$ , Optimized for OIP3,  $50\ \Omega$  test system, Temp.=+25°C

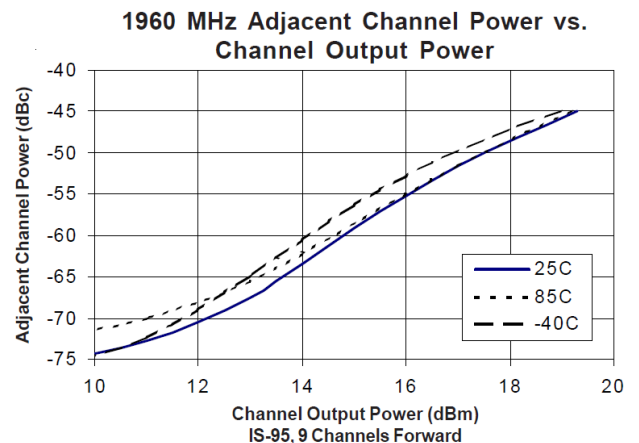
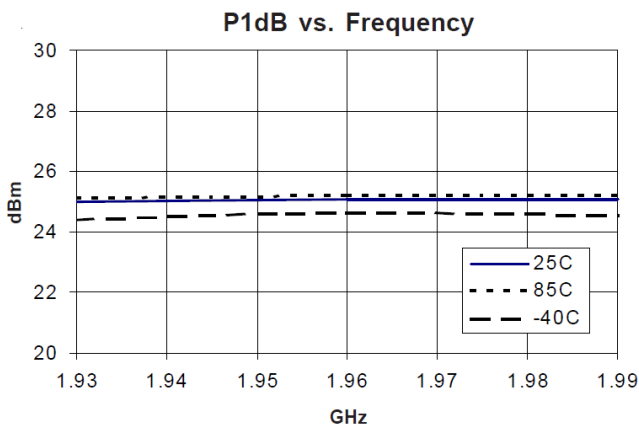
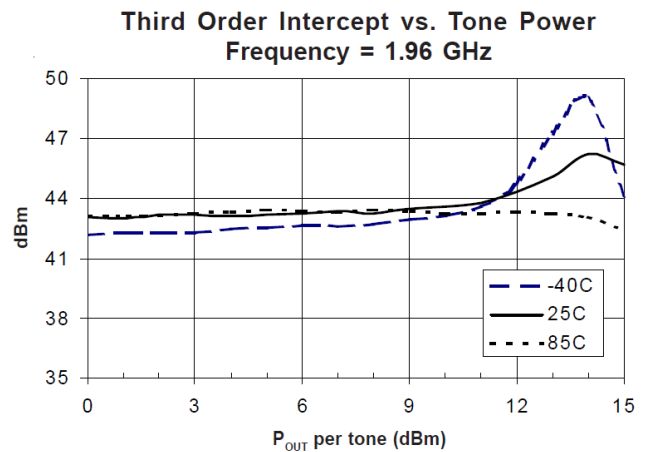
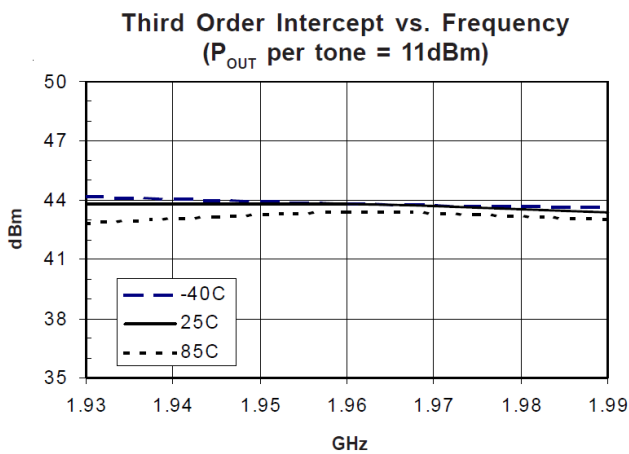
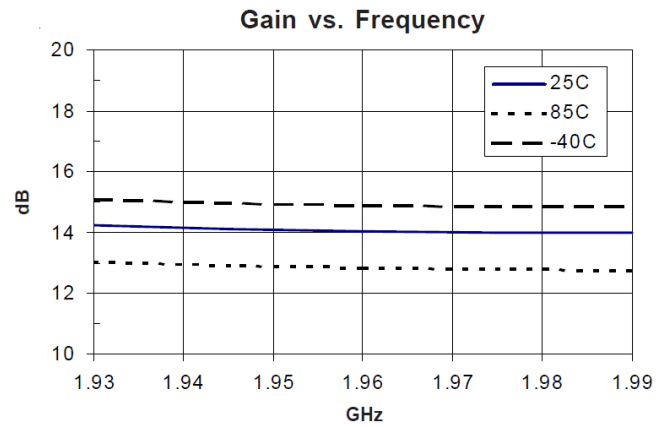
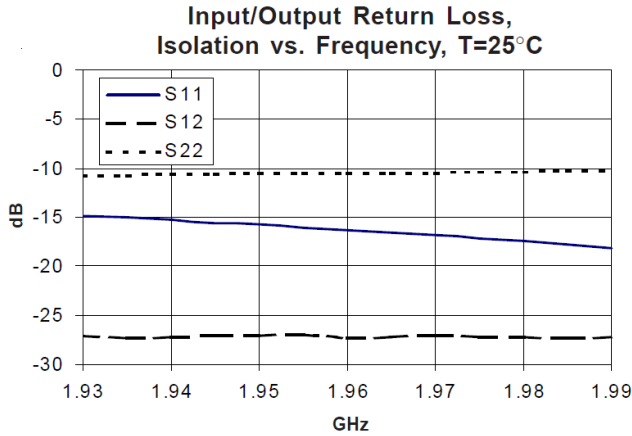



## 2450MHz Application Reference

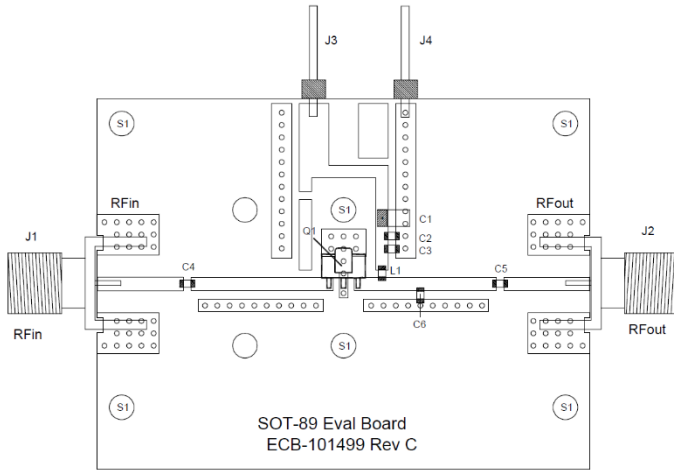

Transmission Line Electrical Lengths  
EL1=35.9° @ 2450 MHz

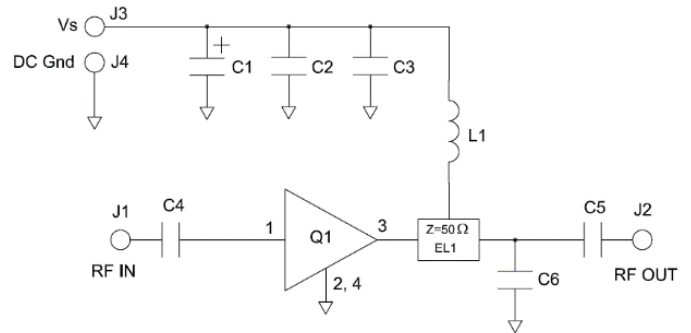

## Bill of Material – 2450MHz Application Reference

Reference Des.	Value	Description	Manuf.	Part Number
PCB	-	Printed Circuit Board	Qorvo	268409
Q1	-	AMP, GaAs HBT, SOT-89	Qorvo	SXA389Z
C1	0.1 μF	CAP, 0.1 μF, 20%, 35V, TANT-A	AVX	TAJA104M035R
C2	1000 pF	CAP, 1000 pF, 10%, 50V, X7R, 0603	Murata	GRM188R71H102KA01D
C3, C5	22 pF	CAP, 22 pF, 5%, 50V, NPO, 0603	Murata	GRM1885C1H470JA01D
C4	1.2 pF	CAP, 1.2 pF, ±0.05 pF, 250V, Hi-Q, 0603	ATC	600S1R2AW250XT
C6	0.5 pF	CAP, 0.5 pF, ±0.25 pF, 50V, C0G, 0603	Murata	GRM1885C1H3R9BA01D
L1	15 nH	IND, 15 nH, 5%, 600mA, M/L, 0603	Murata	LQG18HN15NJ00D
J1, J2	-	CONN, SMA, END LAUNCH, 0.031"	Cinch	142-0701-881

## Transmission Line Electrical Length – 2450MHz Application Reference

Reference Des.	Value	Description
EL1	35.9°	At 2450 MHz between Q1 Pin 3 and C6

**2450MHz Performance Plots – Application Reference**

Test conditions unless otherwise noted:  $V_{CC} = +5V$ ,  $I_C = 120mA$ , Optimized for OIP3, 50  $\Omega$  test system, Temp.=+25 °C

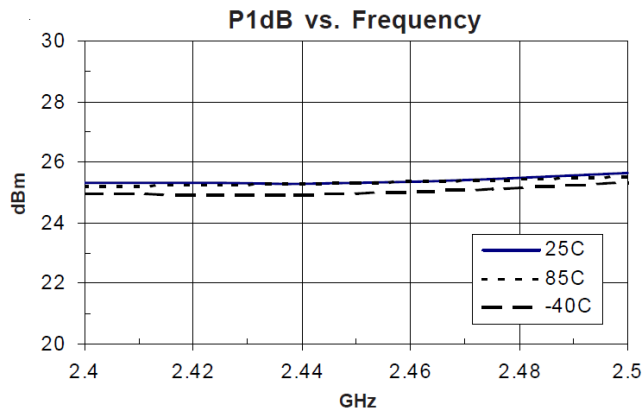
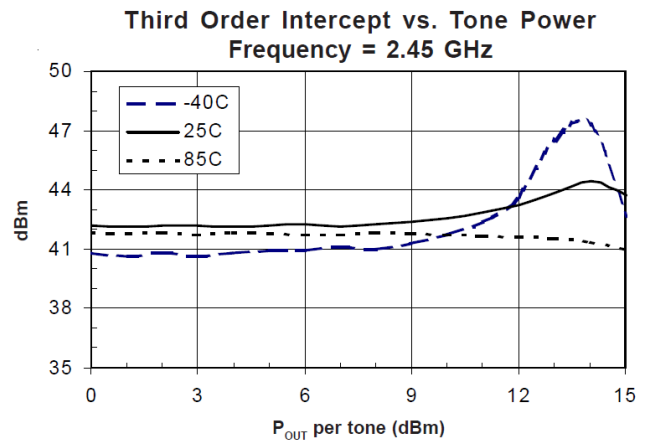
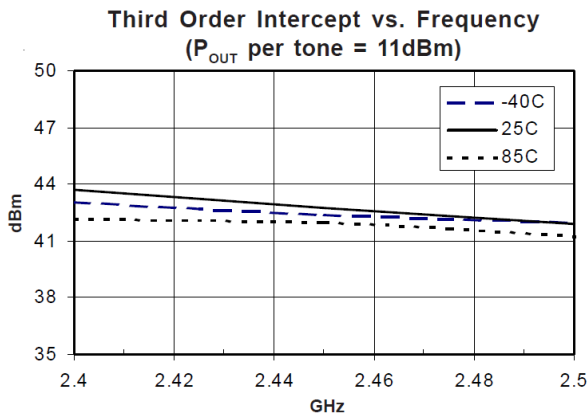
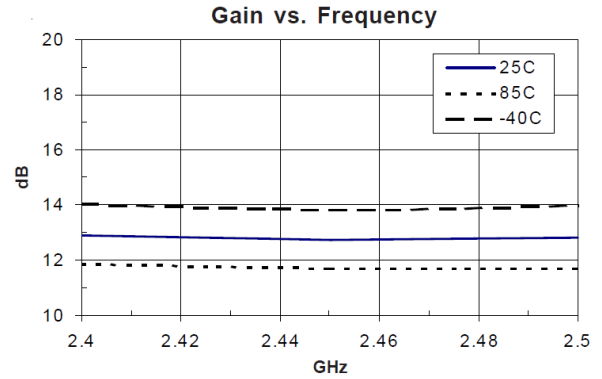
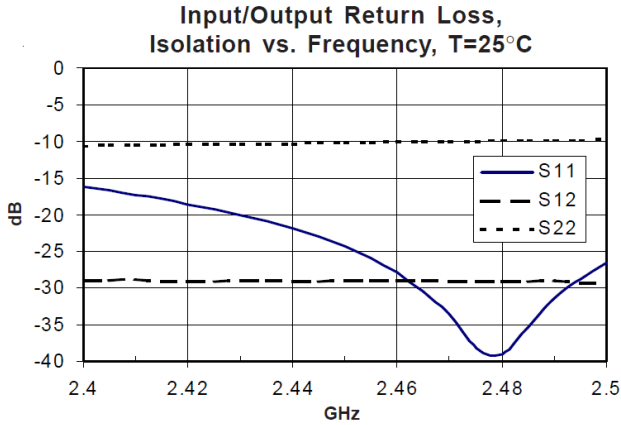

## Pad Configuration and Description

---

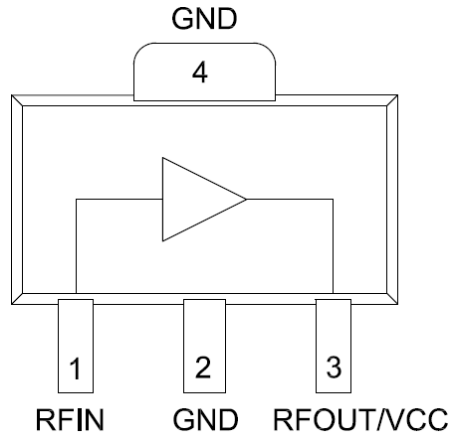

Top View

Pad No.	Label	Description
1	RFIN	RF input, Transistor Base, External DC Block capacitor required.
3	RFOUT / VCC	RF output and DC Supply input, Transistor Collector, External DC Block capacitor required.
2, 4/ Backside Paddle	GND	RF and DC ground, Transistor Emitter, Use recommended via hole pattern to minimize inductance and thermal resistance. See PCB Mounting Pattern for suggested footprint.

## Package Marking and Dimensions

Marking: Part Number – SXA389Z  
 Trace Code – Assigned by sub-contractor

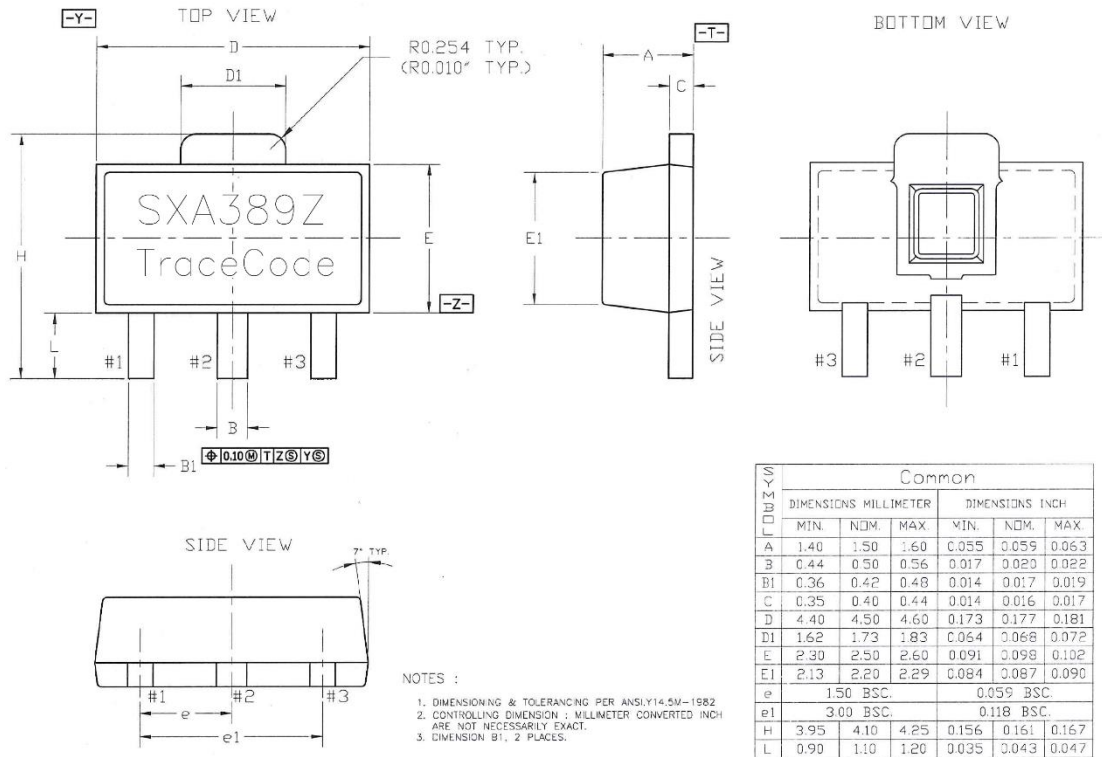

- Notes:
1. All dimensions are in millimeters & inches. Angles are in degrees.
  2. The terminal #1 identifier and terminal numbering conform to JESD 95-1 SPP-012.

## PCB Mounting Pattern

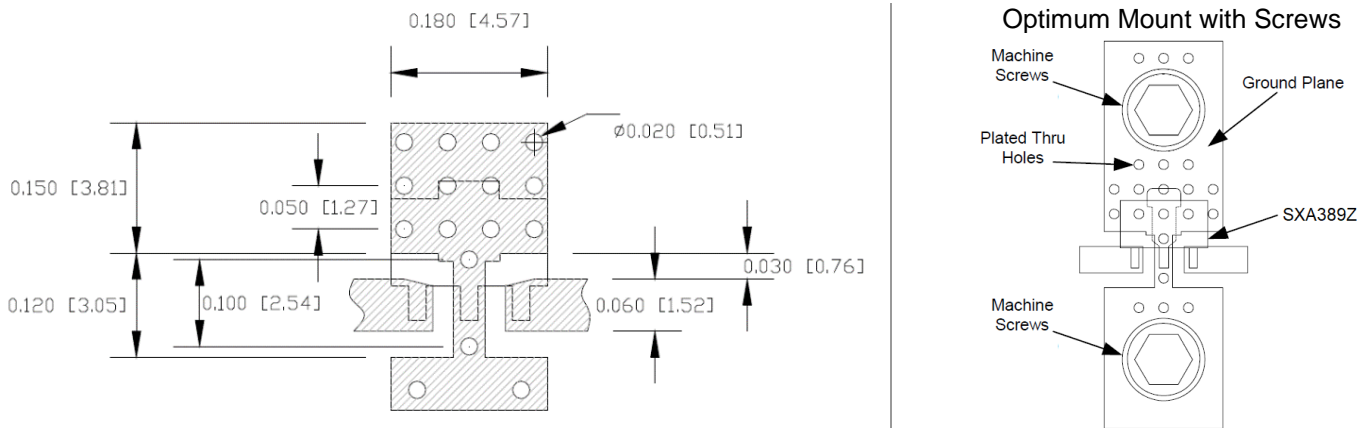

- Notes:
1. All dimensions are in millimeters. Angles are in degrees.
  2. Use 1 oz. copper minimum for top and bottom layer metal.
  3. Ensure good package backside paddle solder attach for reliable operation and best electrical performance.

**Tape and Reel Information – Carrier and Cover Tape Dimensions**

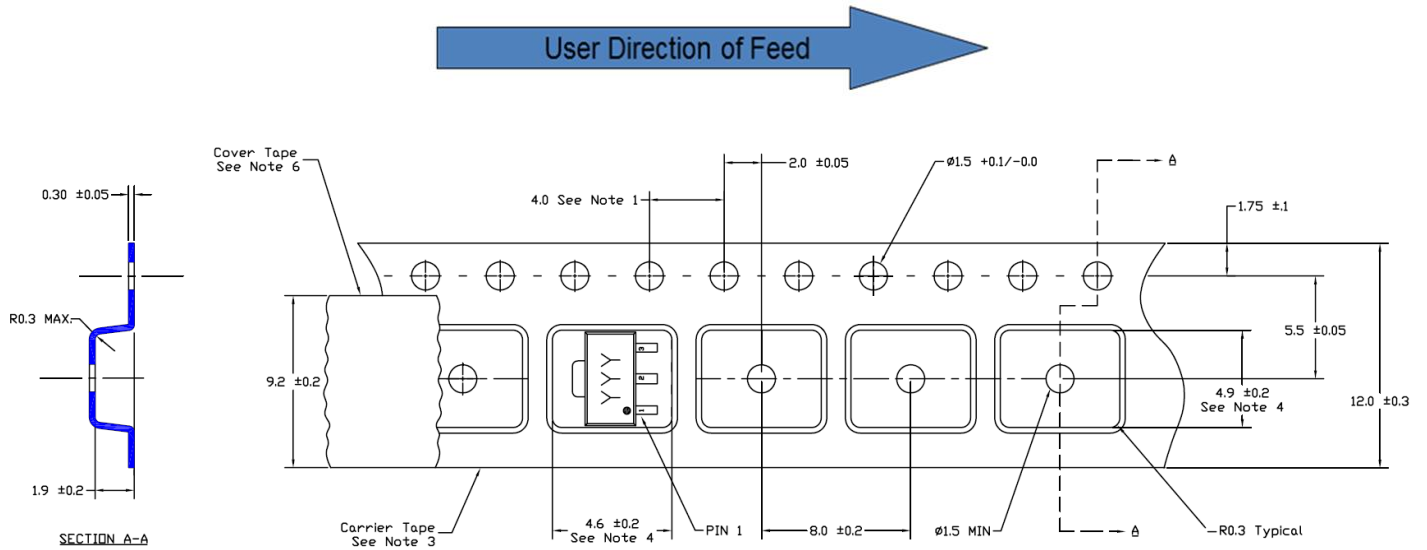

- 1. 10 sprocket hole pitch cumulative tolerance
- 2. Camber not to exceed 1mm in 100mm
- 3. Material: Black Conductive Polystyrene
- 4. Measured on a plane 0.3mm above the bottom of the pocket
- 5. Measured from a plane on the inside bottom of the pocket to the top surface of the carrier.
- 6. Material: Antistatic Polyester Film

Feature	Measure	Symbol	Size (in)	Size (mm)
Cavity	Length	A0	0.181	4.60
	Width	B0	0.193	4.90
	Depth	K0	0.075	1.90
	Pitch	P1	0.315	8.00
Centerline Distance	Cavity to Perforation - Length Direction	P2	0.079	2.00
	Cavity to Perforation - Width Direction	F	0.217	5.50
Cover Tape	Width	C	0.362	9.20
Carrier Tape	Width	W	0.472	12.0

**Tape and Reel Information – Reel Dimensions**

Standard T/R size = 1,000 pieces on a 7" reel.

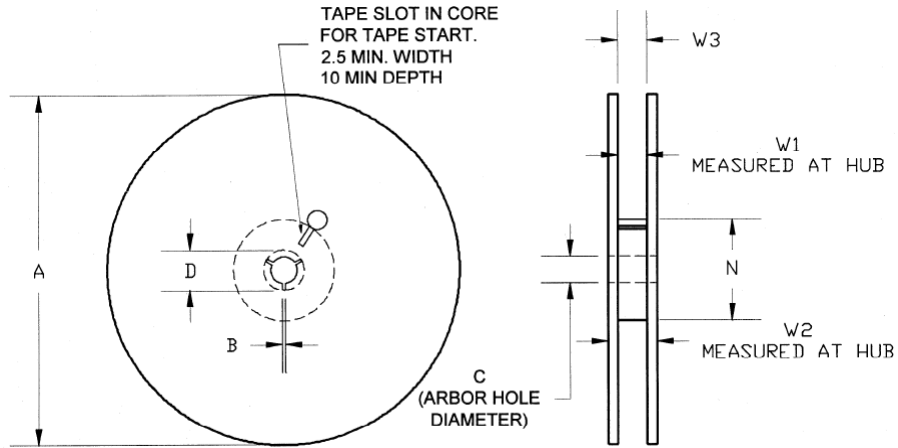

Feature	Measure	Symbol	Size (in)	Size (mm)
Flange	Diameter	A	6.969	177.0
	Thickness	W2	0.717	18.2
	Space Between Flange	W1	0.504	12.8
Hub	Outer Diameter	N	2.283	58.0
	Arbor Hole Diameter	C	0.512	13.0
	Key Slit Width	B	0.079	2.0
	Key Slit Diameter	D	0.787	20.0

**Tape and Reel Information – Tape Length and Label Placement**

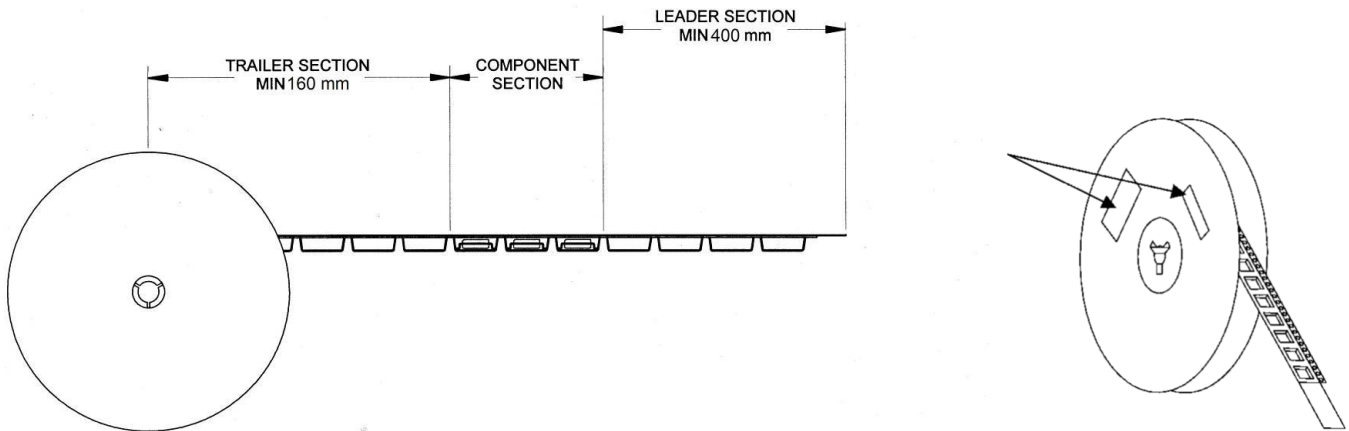

- Notes:
1. Empty part cavities at the trailing and leading ends are sealed with cover tape. See EIA 481-1-A.
  2. Labels are placed on the flange opposite the sprockets in the carrier tape.

## Handling Precautions

Parameter	Rating	Standard
ESD – Human Body Model (HBM)	Class 1B	JEDEC JS-001-2010
MSL – Moisture Sensitivity Level	Level 3	IPC/JEDEC J-STD-020



Caution!  
 ESD-Sensitive Device

## Solderability

Compatible with both lead-free (260°C max. reflow temp.) and tin/lead (245°C max. reflow temp.) soldering processes. Solder profiles available upon request.

Contact plating: NiPdAu

## RoHS Compliance

This part is compliant with 2011/65/EU RoHS directive (Restrictions on the Use of Certain Hazardous Substances in Electrical and Electronic Equipment) as amended by Directive 2015/863/EU.

This product also has the following attributes:

- Lead Free
- Halogen Free (Chlorine, Bromine)
- Antimony Free
- TBBP-A (C<sub>15</sub>H<sub>12</sub>Br<sub>4</sub>O<sub>2</sub>) Free
- PFOS Free
- SVHC Free



## Contact Information

For the latest specifications, additional product information, worldwide sales and distribution locations:

**Web:** [www.qorvo.com](http://www.qorvo.com)

**Tel:** 1-844-890-8163

**Email:** [customer.support@qorvo.com](mailto:customer.support@qorvo.com)

## Important Notice

The information contained herein is believed to be reliable; however, Qorvo makes no warranties regarding the information contained herein and assumes no responsibility or liability whatsoever for the use of the information contained herein. All information contained herein is subject to change without notice. Customers should obtain and verify the latest relevant information before placing orders for Qorvo products. The information contained herein or any use of such information does not grant, explicitly or implicitly, to any party any patent rights, licenses, or any other intellectual property rights, whether with regard to such information itself or anything described by such information. **THIS INFORMATION DOES NOT CONSTITUTE A WARRANTY WITH RESPECT TO THE PRODUCTS DESCRIBED HEREIN, AND QORVO HEREBY DISCLAIMS ANY AND ALL WARRANTIES WITH RESPECT TO SUCH PRODUCTS WHETHER EXPRESS OR IMPLIED BY LAW, COURSE OF DEALING, COURSE OF PERFORMANCE, USAGE OF TRADE OR OTHERWISE, INCLUDING THE IMPLIED WARRANTIES OF MERCHANTABILITY AND FITNESS FOR A PARTICULAR PURPOSE.**

Without limiting the generality of the foregoing, Qorvo products are not warranted or authorized for use as critical components in medical, life-saving, or life-sustaining applications, or other applications where a failure would reasonably be expected to cause severe personal injury or death.

Copyright 2021 © Qorvo, Inc. | Qorvo is a registered trademark of Qorvo, Inc.