

100 Watt Discrete Power GaN on SiC HEMT

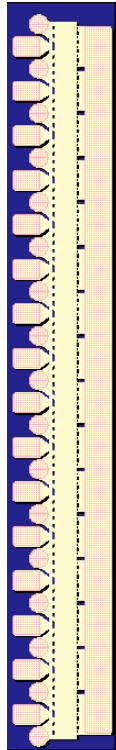

Key Features

- Frequency Range: DC - 18 GHz
- > 50 dBm Nominal Psat
- 55% Maximum PAE
- 15 dB Nominal Power Gain
- Bias: Vd = 28 - 40 V, Idq = 2 A, Vg = -3 V Typical
- Technology: 0.25 um Power GaN on SiC
- Chip Dimensions: 0.82 x 4.56 x 0.10 mm

Primary Applications

- Space
- Military
- Broadband Wireless

Measured Performance

Bias conditions: Vd = 28 - 40 V, Idq = 2 A, Vg = -3 V Typical

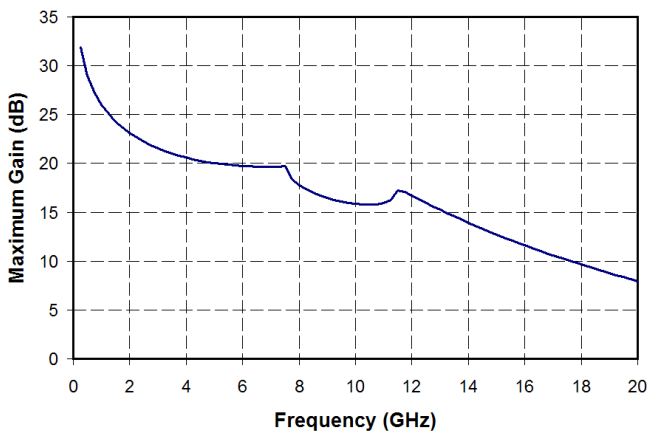

Product Description

The TriQuint TGF2023-20 is a discrete 20 mm GaN on SiC HEMT which operates from DC-18 GHz. The TGF2023-20 is designed using TriQuint's proven 0.25um GaN production process. This process features advanced field plate techniques to optimize microwave power and efficiency at high drain bias operating conditions.

The TGF2023-20 typically provides > 50 dBm of saturated output power with power gain of 15 dB. The maximum power added efficiency is 55% which makes the TGF2023-20 appropriate for high efficiency applications.

Lead-free and RoHS compliant

Datasheet subject to change without notice.

Table I
Absolute Maximum Ratings 1/

Symbol	Parameter	Value	Notes
Vd	Drain Voltage	40 V	<u>2/</u>
Vg	Gate Voltage Range	-10 to 0 V	
Id	Drain Current	20 A	<u>2/</u>
Ig	Gate Current	112 mA	
Pin	Input Continuous Wave Power	38 dBm	<u>2/</u>

- 1/ These ratings represent the maximum operable values for this device. Stresses beyond those listed under “Absolute Maximum Ratings” may cause permanent damage to the device and / or affect device lifetime. These are stress ratings only, and functional operation of the device at these conditions is not implied.
- 2/ Combinations of supply voltage, supply current, input power, and output power shall not exceed the maximum power dissipation listed in Table IV.

Table II
Recommended Operating Conditions

Symbol	Parameter	Value
Vd	Drain Voltage	28 - 40 V
Idq	Drain Current	2 A
Id_Drive	Drain Current under RF Drive	6 A
Vg	Gate Voltage	-3 V

Table III
RF Characterization Table 1/
Bias: Vd = 32 V & 40 V, Idq = 2 A, Vg = - 3V Typical

SYMBOL	PARAMETER	Vd = 40 V	Vd = 32 V	UNITS
Power Tuned:				
P _{sat}	Saturated Output Power	50.5	49.5	dBm
PAE	Power Added Efficiency	46	47	%
Gain	Power Gain	15	15	dB
R _p <u>2/</u>	Parallel Resistance	87.79	68.58	Ω·mm
C _p <u>2/</u>	Parallel Capacitance	0.444	0.461	pF/mm
Γ _L <u>3/</u>	Load Reflection Coefficient	0.905 ∠175.4	0.912 ∠176.3	-
Efficiency Tuned:				
P _{sat}	Saturated Output Power	48	47.5	dBm
PAE	Power Added Efficiency	55	57	%
Gain	Power Gain	19.5	19.5	dB
R _p <u>2/</u>	Parallel Resistance	190.2	158.1	Ω·mm
C _p <u>2/</u>	Parallel Capacitance	0.263	0.314	pF/mm
Γ _L <u>3/</u>	Load Reflection Coefficient	0.843 ∠169.0	0.866 ∠170.9	-

1/ Values in this table are scaled from a 1.25 mm unit GaN on SiC cell at 3.5 GHz

2/ Large signal equivalent GaN on SiC output network

3/ Optimum load impedance for maximum power or maximum PAE at 3.5 GHz. The series resistance and inductance (R_d and L_d) shown in the Figure on page 5 is excluded

Table IV
Power Dissipation and Thermal Properties 1/

Parameter	Test Conditions	Value	Notes
Maximum Power Dissipation	Tbaseplate = 75 °C	Pd = 80 W Tchannel = 150 °C Tm = 2.0E+6 Hrs	<u>2/ 3/</u>
Thermal Resistance, θ_{jc}	Vd = 40 V Id = 2 A Pd = 80 W Tbaseplate = 75 °C	$\theta_{jc} = 1.0$ (°C/W) Tchannel = 150 °C Tm = 2.0E+6 Hrs	
Thermal Resistance, θ_{jc} Under RF Drive	Vd = 40 V Id = 6 A Pout = 50.5 dBm Pd = 127.8 W Tbaseplate = 22 °C	$\theta_{jc} = 1.0$ (°C/W) Tchannel = 150 °C Tm = 2.0E+6 Hrs	<u>4/</u>
Mounting Temperature	30 Seconds	320 °C	
Storage Temperature		-65 to 150 °C	

1/ Assumes eutectic attach using 1mil thick 80/20 AuSn mounted to a 10mil CuMo Carrier Plate

2/ For a median life of 2E+6 hours, Power Dissipation is limited to

$$Pd(max) = (150\text{ °C} - Tbase\text{ °C})/\theta_{jc}$$

3/ Channel operating temperature will directly affect the device median time to failure (MTTF). For maximum life, it is recommended that channel temperatures be maintained at the lowest possible levels.

4/ Channel temperatures at high drain voltages can be excessive, leading to reduced MTTF. Operation at reduced baseplate temperatures and/or pulsed RF modulation is recommended.

Power De-rating Curve

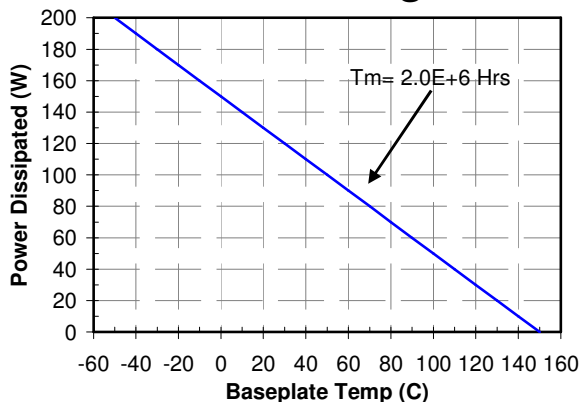

Linear Model for 1.25 mm Unit GaN Cell

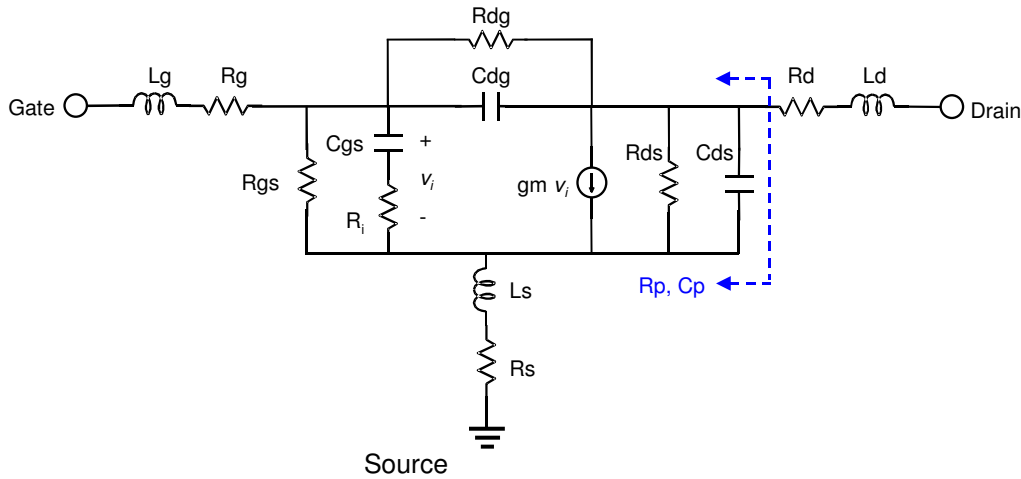

MODEL PARAMETER	Vd = 40V Idq = 19mA	Vd = 32V Idq = 19mA	UNITS
Rg	0.56	0.56	Ω
Rs	0.08	0.07	Ω
Rd	0.31	0.33	Ω
gm	0.134	0.138	S
Cgs	1.52	1.50	pF
Ri	0.24	0.23	Ω
Cds	0.239	0.263	pF
Rds	373.7	319.2	Ω
Cgd	0.053	0.0646	pF
Tau	4.11	3.57	pS
Ls	0.0148	0.0147	nH
Lg	-0.0135	-0.013	nH
Ld	0.048	0.0485	nH
Rgs	1550	1950	Ω
Rgd	70500	47800	Ω

Mechanical Drawing

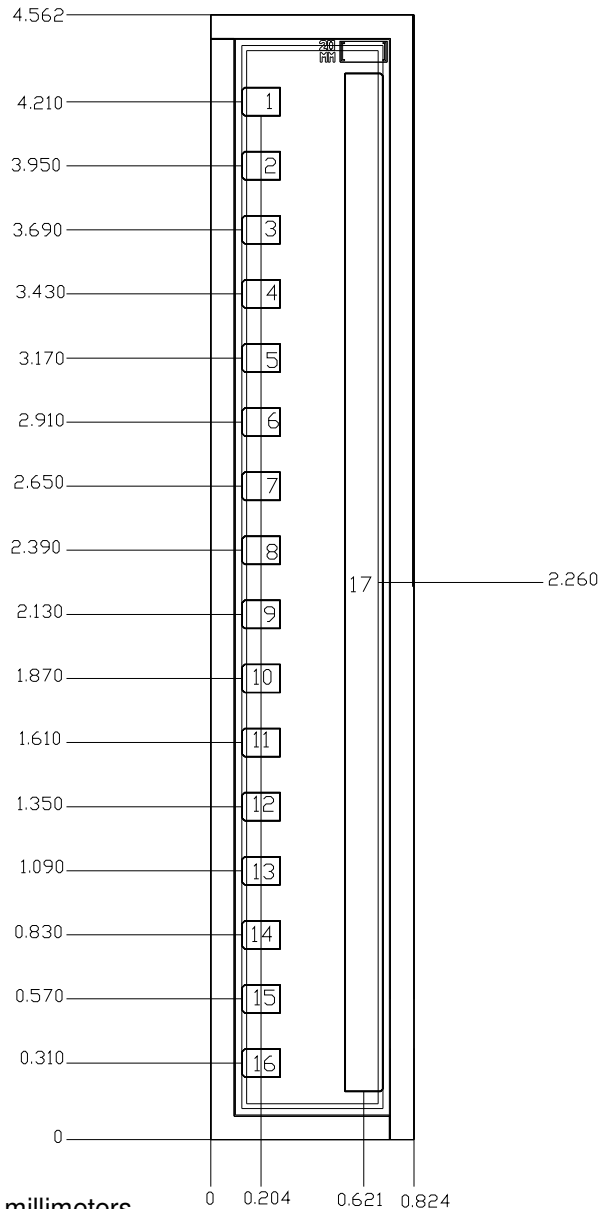

Units: millimeters

Thickness: 0.100

Die x,y size tolerance: +/- 0.050

Chip edge to bond pad dimensions are shown to center of pad

Ground is backside of die

Bond Pad #1 - 16	Vg	0.154 x 0.115
Bond Pad #17	Vd	0.154 x 4.130

GaAs MMIC devices are susceptible to damage from Electrostatic Discharge. Proper precautions should be observed during handling, assembly and test.

Assembly Notes

Component placement and adhesive attachment assembly notes:

- Vacuum pencils and/or vacuum collets are the preferred method of pick up.
- Air bridges must be avoided during placement.
- The force impact is critical during auto placement.
- Organic attachment (i.e. epoxy) can be used in low-power applications.
- Curing should be done in a convection oven; proper exhaust is a safety concern.

Reflow process assembly notes:

- Use AuSn (80/20) solder and limit exposure to temperatures above 300°C to 3-4 minutes, maximum.
- An alloy station or conveyor furnace with reducing atmosphere should be used.
- Do not use any kind of flux.
- Coefficient of thermal expansion matching is critical for long-term reliability.
- Devices must be stored in a dry nitrogen atmosphere.

Interconnect process assembly notes:

- Ball bonding is the preferred interconnect technique, except where noted on the assembly diagram.
- Force, time, and ultrasonics are critical bonding parameters.
- Aluminum wire should not be used.
- Devices with small pad sizes should be bonded with 0.0007-inch wire.

Ordering Information

Part	Package Style
TGF2023-20	GaN on SiC Die

GaAs MMIC devices are susceptible to damage from Electrostatic Discharge. Proper precautions should be observed during handling, assembly and test.

Mouser Electronics

Authorized Distributor

Click to View Pricing, Inventory, Delivery & Lifecycle Information:

[Qorvo:](#)

[TGF2023-20](#)