

< High-power GaAs FET (small signal gain stage) >

MGF0915A

L & S BAND / 4.5W
SMD non - matched

DESCRIPTION

The MGF0915A GaAs FET with an N-channel schottky Gate, is designed for use UHF band amplifiers.

FEATURES

- High output power
Po=36.5dBm(TYP.) @f=1.9GHz,Pin=23dBm
- High power gain
Gp=14.5dB(TYP.) @f=1.9GHz
- High power added efficiency
ηadd=50%(TYP.) @f=1.9GHz,Pin=23dBm
- Hermetic Package

APPLICATION

- For UHF Band power amplifiers

QUALITY

- GG

RECOMMENDED BIAS CONDITIONS

- Vds=10V • Ids=800mA • Rg=100Ω

Delivery -01:Tape & Reel(1K), -03:Trai(50pcs)

Absolute maximum ratings (Ta=25°C)

Symbol	Parameter	Ratings	Unit
VGSO	Gate to source breakdown voltage	-15	V
VGDO	Gate to drain breakdown voltage	-15	V
ID	Drain current	3000	mA
IGR	Reverse gate current	-10	mA
IGF	Forward gate current	21	mA
PT	Total power dissipation	18.7	W
Tch	Channel temperature	175	°C
Tstg	Storage temperature	-65 to +175	°C

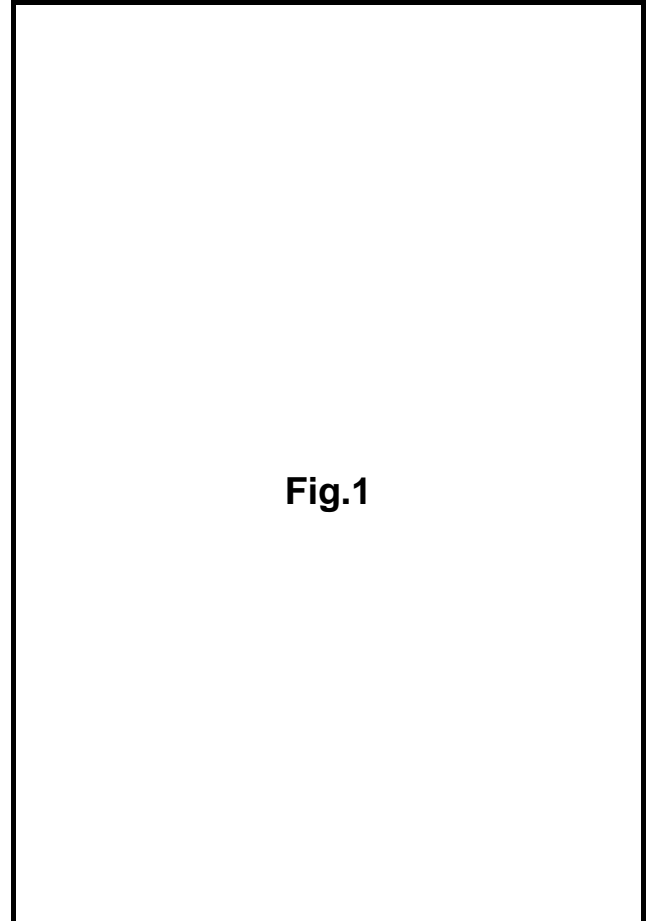

Fig.1

Electrical characteristics (Ta=25°C)

Symbol	Parameter	Test conditions	Limits			Unit
			Min.	Typ.	Max.	
IDSS	Saturated drain current	VDS=3V,VGS=0V	-	2400	3000	mA
VGS(off)	Gate to source cut-off voltage	VDS=3V,ID=10mA	-1	-3	-5	V
gm	Transconductance	VDS=3V,ID=800mA	-	1000	-	mS
Po	Output power	VDS=10V,ID=800mA,f=1.9GHz	35.0	36.5	-	dBm
ηadd	Power added Efficiency	Pin=23dBm	-	50	-	%
GLP	Linear Power Gain	VDS=10V,ID=800mA,f=1.9GHz	13.0	14.5	-	dB
Rth(ch-c)	Thermal Resistance *1	ΔVf Method	-	5	8	°C/W

*1:Channel to case / Above parameters, ratings, limits are subject to change.

MGF0915A

L & S BAND / 4.5W
SMD non - matched

MGF0915A TYPICAL CHARACTERISTICS

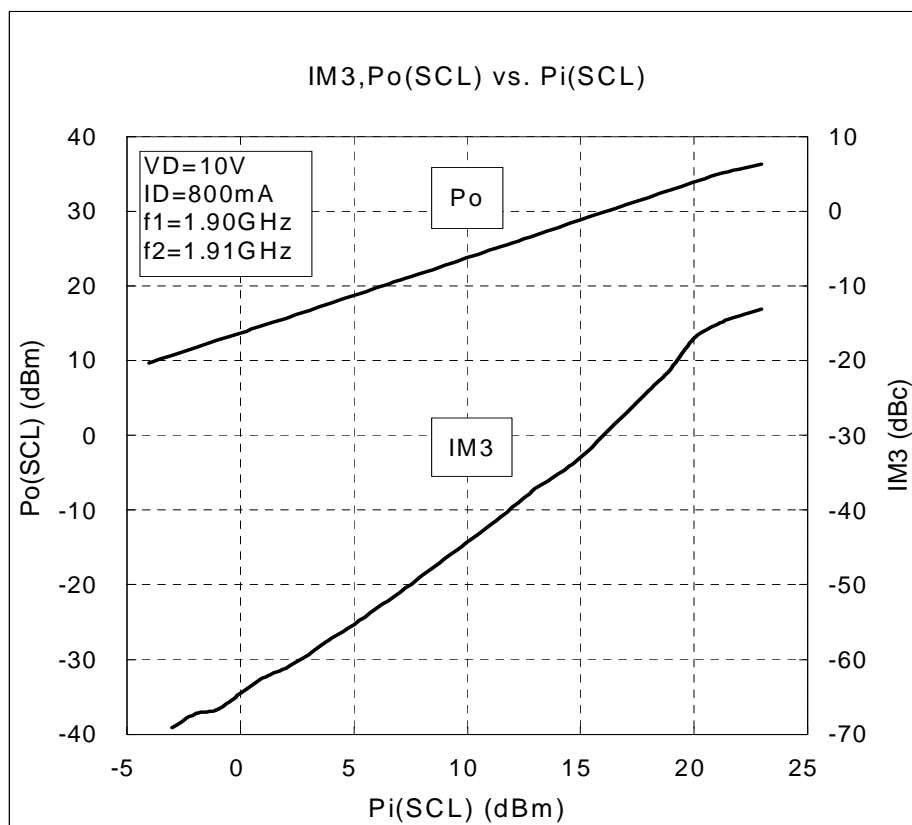
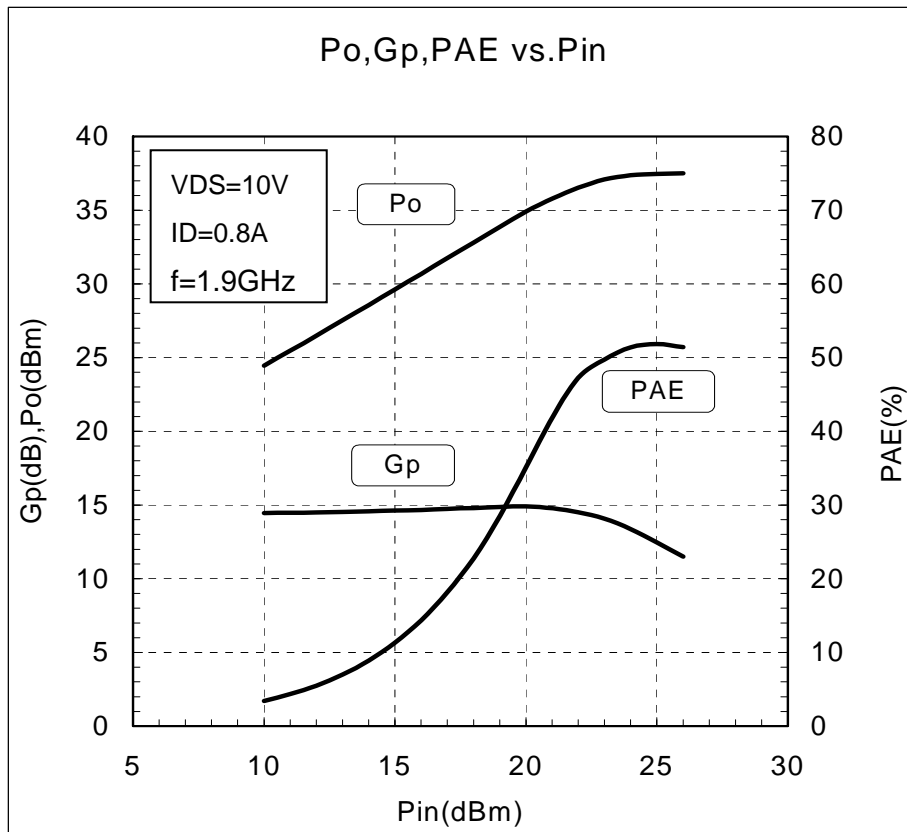

< High-power GaAs FET (small signal gain stage) >

MGF0915A

L & S BAND / 4.5W
SMD non - matched

MGF0915A S PARAMETERS (Ta=25°C,VD=10V,ID=800mA, Reference Plane see Fig.1)

freq. (MHz)	S11		S21		S12		S22		K	MAG/MSG (dB)
	(mag)	(ang)	(mag)	(ang)	(mag)	(ang)	(mag)	(ang)		
600	0.948	-145.92	4.852	99.38	0.013	24.42	0.721	-177.51	0.38	25.72
1000	0.947	-161.85	2.941	86.78	0.015	26.56	0.717	-178.09	0.63	22.92
1400	0.946	-168.94	2.144	77.11	0.015	28.76	0.719	-178.44	0.84	21.55
1800	0.946	-173.55	1.746	69.39	0.016	30.92	0.725	-178.66	0.94	20.38
2200	0.945	-176.72	1.456	62.91	0.017	32.93	0.732	-178.82	1.03	18.23
2600	0.944	-178.89	1.211	57.13	0.018	34.72	0.739	-178.94	1.14	16.00
3000	0.942	-178.80	1.032	51.69	0.019	36.22	0.745	-179.06	1.27	14.25
3400	0.939	-177.37	0.934	46.34	0.020	37.37	0.749	-179.19	1.34	13.19
3800	0.935	-174.73	0.888	40.95	0.022	38.13	0.751	-179.32	1.34	12.59
4200	0.930	-171.44	0.836	35.45	0.024	38.46	0.751	-179.44	1.38	11.75
4600	0.925	-167.90	0.759	29.81	0.027	38.33	0.749	-179.56	1.43	10.58
5000	0.918	-164.36	0.798	24.04	0.031	37.72	0.745	-179.67	1.27	10.96
5400	0.911	-160.93	0.730	18.15	0.035	36.59	0.740	-179.78	1.33	9.76
5800	0.903	-157.60	0.715	12.14	0.039	34.92	0.732	-179.67	1.32	9.23
6200	0.894	-154.31	0.708	6.01	0.045	32.68	0.724	-177.54	1.26	8.90
6600	0.884	-150.88	0.707	-0.28	0.052	29.84	0.713	-175.25	1.20	8.65
7000	0.871	-147.10	0.711	-6.80	0.060	26.34	0.702	-172.45	1.15	8.38
7400	0.855	-142.73	0.721	-13.66	0.069	22.15	0.688	-169.39	1.12	8.06
7800	0.833	-137.52	0.739	-20.98	0.081	17.18	0.671	-166.53	1.09	7.75
8200	0.807	-131.21	0.765	-28.93	0.094	11.37	0.651	-164.20	1.08	7.43
8600	0.778	-123.58	0.802	-37.70	0.110	4.61	0.624	-162.51	1.04	7.36
9000	0.748	-114.45	0.849	-47.48	0.129	-3.21	0.590	-161.19	1.00	8.18
9400	0.717	-103.71	0.905	-58.48	0.152	-12.23	0.545	-159.72	0.96	7.75
9800	0.688	-91.34	0.964	-70.88	0.179	-22.60	0.487	-157.44	0.93	7.31
10200	0.671	-77.41	1.023	-84.83	0.211	-34.51	0.410	-153.88	0.90	6.86
10600	0.672	-62.12	1.072	-100.40	0.248	-48.17	0.311	-149.13	0.86	6.36
11000	0.697	-45.82	1.100	-117.62	0.293	-63.82	0.184	-144.37	0.81	5.75
11400	0.746	-29.03	1.095	-136.37	0.326	-81.74	0.021	-179.00	0.79	5.26
11800	0.812	-12.43	1.038	-156.40	0.346	-102.24	0.194	-81.10	0.79	4.77
12200	0.877	-3.09	0.913	-177.29	0.346	-125.67	0.404	-95.22	0.79	4.21

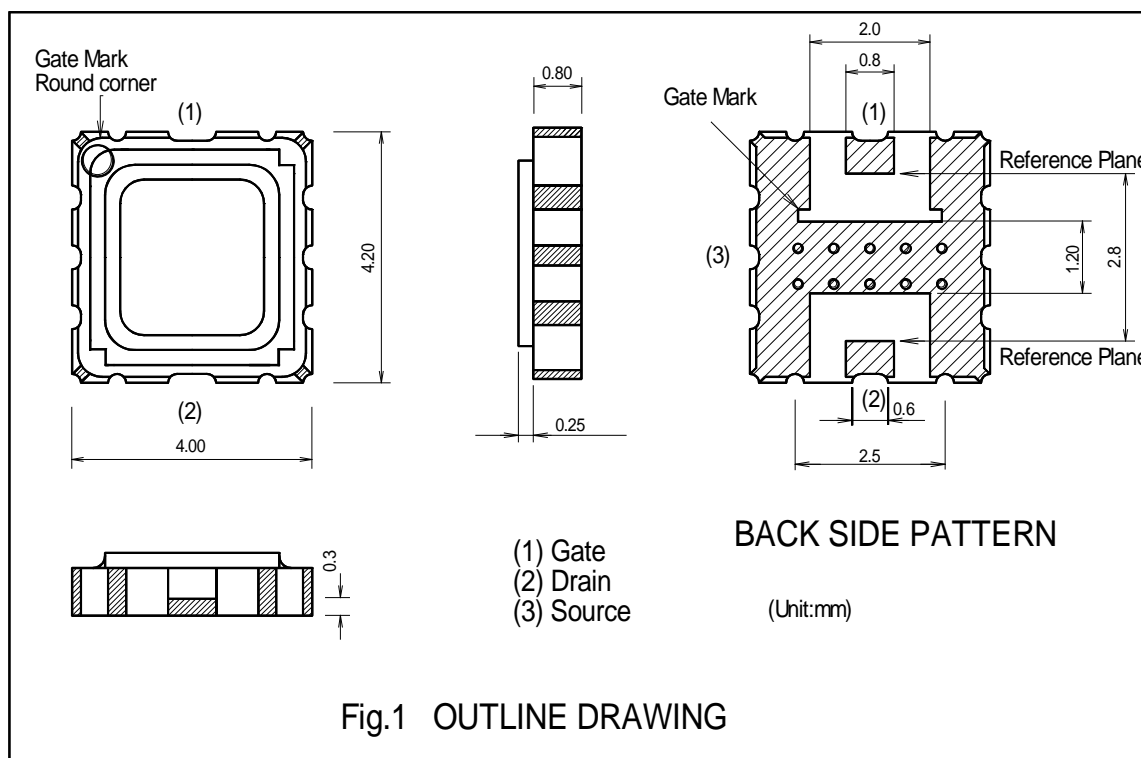

Keep safety first in your circuit designs!

Mitsubishi Electric Corporation puts the maximum effort into making semiconductor products better and more reliable, but there is always the possibility that trouble may occur with them. Trouble with semiconductors may lead to personal injury, fire or property damage. Remember to give due consideration to safety when making your circuit designs, with appropriate measures such as (i) placement of substitutive, auxiliary circuits, (ii) use of non-flammable material or (iii) prevention against any malfunction or mishap.

Notes regarding these materials

- These materials are intended as a reference to assist our customers in the selection of the Mitsubishi semiconductor product best suited to the customer's application; they do not convey any license under any intellectual property rights, or any other rights, belonging to Mitsubishi Electric Corporation or a third party.
- Mitsubishi Electric Corporation assumes no responsibility for any damage, or infringement of any third-party's rights, originating in the use of any product data, diagrams, charts, programs, algorithms, or circuit application examples contained in these materials.
- All information contained in these materials, including product data, diagrams, charts, programs and algorithms represents information on products at the time of publication of these materials, and are subject to change by Mitsubishi Electric Corporation without notice due to product improvements or other reasons. It is therefore recommended that customers contact Mitsubishi Electric Corporation or an authorized Mitsubishi Semiconductor product distributor for the latest product information before purchasing a product listed herein.
The information described here may contain technical inaccuracies or typographical errors. Mitsubishi Electric Corporation assumes no responsibility for any damage, liability, or other loss rising from these inaccuracies or errors.
Please also pay attention to information published by Mitsubishi Electric Corporation by various means, including the Mitsubishi Semiconductor home page (<http://www.MitsubishiElectric.com/>).
- When using any or all of the information contained in these materials, including product data, diagrams, charts, programs, and algorithms, please be sure to evaluate all information as a total system before making a final decision on the applicability of the information and products. Mitsubishi Electric Corporation assumes no responsibility for any damage, liability or other loss resulting from the information contained herein.
- Mitsubishi Electric Corporation semiconductors are not designed or manufactured for use in a device or system that is used under circumstances in which human life is potentially at stake. Please contact Mitsubishi Electric Corporation or an authorized Mitsubishi Semiconductor product distributor when considering the use of a product contained herein for any specific purposes, such as apparatus or systems for transportation, vehicular, medical, aerospace, nuclear, or undersea repeater use.
- The prior written approval of Mitsubishi Electric Corporation is necessary to reprint or reproduce in whole or in part these materials.
- If these products or technologies are subject to the Japanese export control restrictions, they must be exported under a license from the Japanese government and cannot be imported into a country other than the approved destination.
Any diversion or re-export contrary to the export control laws and regulations of Japan and/or the country of destination is prohibited.
- Please contact Mitsubishi Electric Corporation or an authorized Mitsubishi Semiconductor product distributor for further details on these materials or the products contained therein.