

5 Volt-Surface Mount

# Monolithic Amplifier

LHY-84+

50Ω DC to 7 GHz

## The Big Deal

- High Gain, 24.4 dB typ. at 10 MHz
- High P1dB, 20.8 dB typ. at 10 MHz
- High IP3, 38.5 dBm typ. at 10 MHz
- Small size, 2 x 2mm



2mm x 2mm

## Product Overview

LHY-84+ (RoHS compliant) is a wideband amplifier offering high dynamic range. Lead finish is matte-tin. It has repeatable performance from lot to lot and is enclosed in a 2mm x 2mm MCLP package. It uses patented Transient Protected Darlington configuration and is fabricated using InGaP HBT technology.

## Key Features

Feature	Advantages
Broad Band: DC to 7 GHz	Broadband covering primary wireless communications bands: CATV & DBS, MMDS & Wireless LAN, LTE
Combination of high P1dB & OIP3: P1dB, 20.8 dBm at 10 MHz OIP3, 38.5 dBm at 10 MHz	The LHY-84+ matches industry leading IP3 performance relative to device size and power consumption. IP3 is typically 12-18 dB above the P1dB point. This feature makes this amplifier ideal for use in: <ul style="list-style-type: none"><li>• Driver amplifiers for complex waveform up converter paths</li><li>• Drivers in linearized transmit systems</li><li>• Secondary amplifiers in ultra High Dynamic range receivers</li></ul>
High Gain, 24 dB typ. at 100 MHz	Minimizes number of stages, PCB space and cost to achieve high gain.
Small 2 x 2mm, 6-lead MCLP package	Tiny footprint saves space in dense layouts while providing low inductance, repeatable transitions, and excellent thermal contact to the PCB.



# 5 Volt-Surface Mount Monolithic Amplifier

## LHY-84+

### 50Ω DC to 7 GHz

#### Product Features

- High Gain, 24.4 dB typ. at 10 MHz
- High Pout, P1dB 20.8 dBm typ. at 10 MHz
- High IP3, 38.5 dBm typ. at 10 MHz
- Ruggedized design
- Fixed 5V operation
- Unconditionally stable
- Excellent ESD Protection
- Transient protected, US patent 6,943,629



Generic photo used for illustration purposes only

CASE STYLE: MC1630-1

#### +RoHS Compliant

The +Suffix identifies RoHS Compliance. See our web site for RoHS Compliance methodologies and qualifications

#### Typical Applications

- Base station infrastructure
- Portable Wireless
- CATV & DBS
- MMDS & Wireless LAN
- LTE

#### General Description

LHY-84+ (RoHS compliant) is a wideband amplifier offering high dynamic range. Lead finish is matte-tin. It has repeatable performance from lot to lot and is enclosed in a 2mm x 2mm MCLP package. It uses patented Transient Protected Darlington configuration and is fabricated using InGaP HBT technology.

#### simplified schematic and pin description

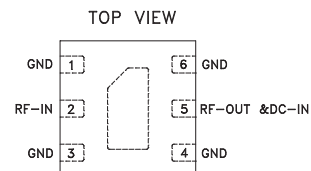
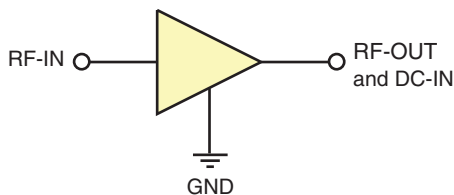

Function	Pin Number	Description
RF-IN	2	RF input pin. This pin requires the use of an external DC blocking capacitor chosen for the frequency of operation
RF-OUT and DC-IN	5	RF output and bias pin. DC voltage is present on this pin; therefore a DC blocking capacitor is necessary for proper operation. An RF choke is needed to feed DC bias without loss of RF signal due to the bias connection, as shown in "Recommended Application Circuit", Fig. 2
GND	1,3,4,6 & paddle	Connections to ground. Use via holes as shown in "Suggested Layout for PCB Design" to reduce ground path inductance for best performance.

Electrical Specifications at 25°C, 5V & 50 ohms, unless noted

Parameter	Condition (MHz)	Vd=5V <sup>1</sup>			Vd=5V <sup>2</sup>	Units
		Min.	Typ.	Max.	Typ.	
Frequency range <sup>6</sup>		DC		7	DC-7	GHz
Gain	10	22	24.4	26.8	24.3	dB
	1000	20.5	22.8	25.1	22.7	
	2000	17.9	20.0	21.9	19.9	
	4000	13.4	15.7	16.4	14.5	
	6000	—	11.8	—	9.9	
	7000	—	9.8	—	7.9	
Input return loss	10	18	24	—	22	dB
	1000	13	17	—	18	
	2000	10	15	—	15	
	4000	—	15	—	11	
	6000	—	14	—	10	
	7000	—	12	—	9	
Output return loss	10	16	22	—	20	dB
	1000	—	9	—	9	
	2000	—	6	—	6	
	4000	—	6	—	5	
	6000	—	6	—	5	
	7000	—	5	—	6	
Reverse isolation	2000		28		28	dB
Output power @ 1dB compression	10		20.8		20.1	dBm
	1000		21.0		20.7	
	2000		21.1		20.6	
	4000		19.6		19.0	
	6000		16.8		15.5	
	7000		15.5		14.0	
Output IP3 <sup>3</sup>	10	32.3	38.5	—	36.7	dBm
	1000	30.6	34.4	—	34.5	
	2000	28.7	33.1	—	33.5	
	4000	—	31.1	—	30.8	
	6000	—	29.7	—	27.7	
	7000	—	27.9	—	26.8	
Noise figure	10		5.1		5.1	dB
	1000		5.2		5.1	
	2000		5.4		5.5	
	4000		5.6		5.9	
	6000		6.1		6.4	
	7000		6.5		6.9	
Device operating voltage		4.75	5.0	5.25	5.0	V
Device operating current			111	130	106	mA
Device current variation vs. temperature <sup>4</sup>			78		78	μA/°C
Device current variation vs voltage <sup>5</sup>			0.057		0.055	mA/mV
Thermal Resistance, junction-to-ground lead at 85°C stage			64		64	°C/W

1. Measured on Mini-Circuits Characterization test board TB-621+. See Characterization Test Circuit (Fig. 1)
2. Measured on Mini-Circuits Application test board TB-1064+. See Characterization Test Circuit (Fig. 2)
3. Tested at Pout=0dBm / tone.
4. (Current at 85°C — Current at -45°C)/130
5. (Current at 5.25V-current - Current at 4.75V)/1000
6. Guaranteed specifications DC-7 GHz. Low frequency cut-off determined by external coupling capacitors and external bias choke.

Absolute Maximum Ratings<sup>7</sup>

Parameter	Ratings
Operating Temperature (ground lead)	-40°C to 85°C
Storage Temperature	-65°C to 150°C
Power Dissipation	1W
Input Power (CW)	+13 dBm
DC Voltage on Pad 5	5.8V

7. Permanent damage may occur if any of these limits are exceeded.  
Electrical maximum ratings are not intended for continuous normal operation.



### Characterization Test Circuit

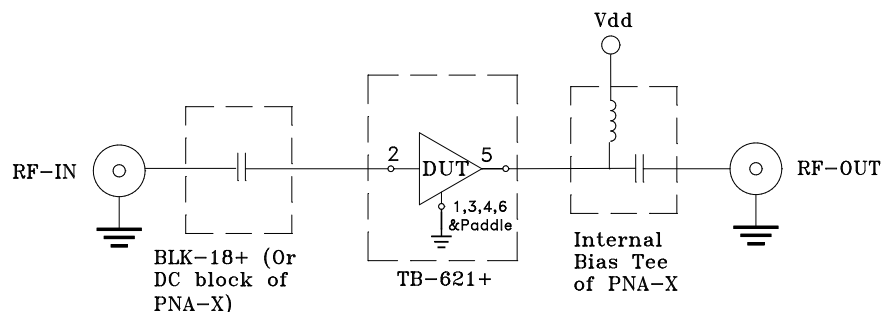

Fig 1. Characterization Circuit

Note: This block diagram is used for characterization. (DUT soldered on Mini-Circuits Characterization test board TB-621+) Gain, Return loss, Output power at 1dB compression (P1 dB), output IP3 (OIP3) and noise figure measured using Agilent's N5242A PNA-X microwave network analyzer.

Conditions:

1. Gain and Return loss: Pin= -25dBm
2. Output IP3 (OIP3): Two tones, spaced 1 MHz apart, 0 dBm/tone at output.

### Recommended Application Circuit

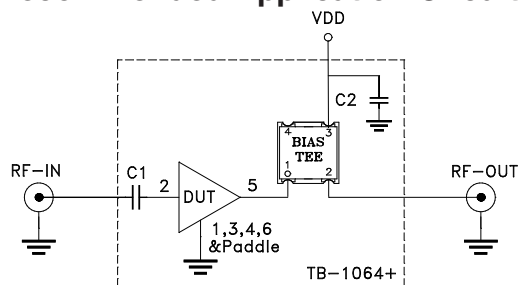

Component	P/N	Supplier	Value	Size
DUT	LHY-84+	MCL	--	2x2 mm
C1	LBB0402X104MGT1C8	Presidio	0.1uF	0402
C2	GRM188R71H103KA01D	Murate	0.01uF	0603
Bias-Tee	TCBT-123+	MCL	--	0.15"x0.15"

Fig 2. Application Circuit

Note: (DUT soldered on Mini-Circuits Application test board TB-1064+). TB-1064+ uses a three layer PCB, see drawing. Gain, Return loss, Output power at 1dB compression (P1 dB), output IP3 (OIP3) and noise figure measured using Agilent's N5242A PNA-X microwave network analyzer.

Conditions:

1. Gain and Return loss: Pin= -25dBm
2. Output IP3 (OIP3): Two tones, spaced 1 MHz apart, 0 dBm/tone at output.

### Product Marking

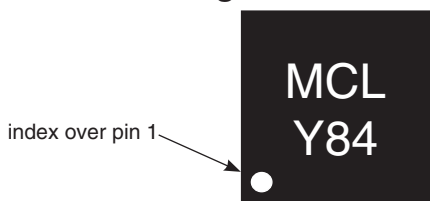

Marking may contain other features or characters for internal lot control

<b>Additional Detailed Technical Information</b> <i>additional information is available on our dash board. To access this information <a href="#">click here</a></i>	
<b>Performance Data</b>	Data Table
	Swept Graphs
	S-Parameter (S2P Files) Data Set (.zip file)
<b>Case Style</b>	MC1630-1 <i>Plastic package, exposed paddle lead finish: Matte Tin</i>
<b>Tape &amp; Reel</b> Standard quantities available on reel	F66 <i>7" reels with 20, 50, 100, 200, 500 or 1K devices</i>
<b>Suggested Layout for PCB Design</b>	PL-593
<b>Evaluation Board</b>	TB-1064+
<b>Environmental Ratings</b>	ENV08T1

### ESD Rating

Human Body Model (HBM): Class 1C (Pass 1000V) in accordance with ANSI/ESD STM 5.1 - 2001

### MSL Test Flow Chart

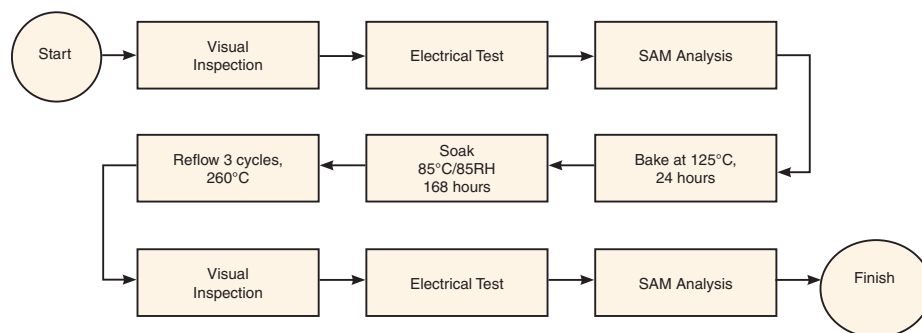

### Additional Notes

- A. Performance and quality attributes and conditions not expressly stated in this specification document are intended to be excluded and do not form a part of this specification document.
- B. Electrical specifications and performance data contained in this specification document are based on Mini-Circuit's applicable established test performance criteria and measurement instructions.
- C. The parts covered by this specification document are subject to Mini-Circuits standard limited warranty and terms and conditions (collectively, "Standard Terms"); Purchasers of this part are entitled to the rights and benefits contained therein. For a full statement of the Standard Terms and the exclusive rights and remedies thereunder, please visit Mini-Circuits' website at [www.minicircuits.com/MCLStore/terms.jsp](http://www.minicircuits.com/MCLStore/terms.jsp)

## Typical Performance Data

**NOTE: Use PDF Bookmarks to view DATA at required conditions**

**Definitions:**

Input Return Loss = -S11 (dB)

Gain(Power Gain) = S21 (dB)

Reverse Isolation = -S12 (dB)

Output Return Loss = -S22 (dB)

TEST CONDITIONS: Vd = 5.00V, Id = 109.39mA @ Temperature = +25°C

FREQ	Gain	Isolation	Input Return Loss	Output Return Loss	Stability		IP-3 Output	1dB Comp. Output	Noise Figure
					K	Measure			
(MHz)	(dB)	(dB)	(dB)	(dB)	K	Measure	(dBm)	(dBm)	(dB)
10	24.43	31.51	24.90	22.94	1.34	0.81	37.10	20.27	5.28
50	24.45	31.42	24.74	22.22	1.33	0.80	37.49	20.93	5.06
100	24.42	31.41	24.62	21.40	1.33	0.80	39.52	20.77	5.03
200	24.34	31.35	23.85	18.92	1.32	0.80	37.92	20.98	5.02
300	24.24	31.24	22.84	16.71	1.30	0.79	37.36	20.94	5.05
400	24.10	31.11	21.84	14.81	1.29	0.78	37.28	20.95	5.02
500	23.94	30.93	20.86	13.31	1.27	0.78	37.05	21.04	5.06
600	23.75	30.74	20.01	12.07	1.24	0.76	37.14	21.00	5.05
700	23.54	30.54	19.13	11.06	1.22	0.75	36.16	20.97	5.14
800	23.31	30.32	18.43	10.22	1.20	0.74	36.15	20.90	5.13
900	23.07	30.10	17.88	9.50	1.17	0.73	35.66	20.89	5.14
1000	22.82	29.88	17.38	8.91	1.15	0.72	34.90	20.99	5.14
1250	22.15	29.33	16.45	7.79	1.11	0.70	34.89	20.83	5.18
1500	21.47	28.79	15.85	7.06	1.08	0.68	33.98	20.94	5.26
1750	20.80	28.26	15.47	6.55	1.06	0.66	33.87	20.96	5.33
2000	20.15	27.75	15.29	6.24	1.05	0.65	33.82	21.09	5.34
2250	19.53	27.25	15.18	6.02	1.04	0.64	34.26	20.91	5.33
2500	18.93	26.75	15.13	5.90	1.04	0.64	34.18	20.61	5.40
2750	18.38	26.27	15.13	5.84	1.04	0.64	33.08	20.74	5.44
3000	17.85	25.79	15.14	5.83	1.05	0.64	32.68	20.83	5.40
3250	17.34	25.33	15.15	5.84	1.05	0.64	32.86	20.60	5.54
3500	16.83	24.90	15.23	5.86	1.06	0.64	33.06	20.30	5.48
3750	16.34	24.48	15.23	5.87	1.07	0.64	32.45	19.92	5.53
4000	15.85	24.10	15.24	5.85	1.08	0.64	31.33	19.78	5.55
4250	15.37	23.74	15.29	5.85	1.10	0.64	31.43	19.67	5.67
4500	14.89	23.39	15.23	5.83	1.12	0.64	30.82	19.30	5.64
4750	14.41	23.08	15.12	5.81	1.14	0.64	30.73	19.00	5.68
5000	13.93	22.78	14.87	5.78	1.15	0.64	30.27	18.63	5.81
5250	13.44	22.52	14.53	5.70	1.18	0.63	30.22	18.23	5.81
5500	12.94	22.29	14.20	5.64	1.20	0.63	30.15	17.75	5.89
5750	12.45	22.08	13.83	5.55	1.23	0.63	29.86	17.40	5.98
6000	11.94	21.89	13.44	5.50	1.26	0.64	29.81	16.97	6.01
6250	11.44	21.72	13.05	5.43	1.29	0.64	29.52	16.55	6.13
6500	10.95	21.56	12.61	5.34	1.32	0.64	29.04	16.23	6.21
6750	10.46	21.42	12.24	5.27	1.35	0.64	28.92	15.82	6.31
7000	9.96	21.29	11.87	5.21	1.39	0.64	27.96	15.56	6.37
7250	9.48	21.16	11.53	5.17	1.43	0.65	28.21	15.14	6.45
7500	9.01	21.04	11.19	5.15	1.46	0.65	27.23	14.87	6.56

## Typical Performance Data

### Definitions:

Input Return Loss = -S11 (dB)

Gain(Power Gain) = S21 (dB)

Reverse Isolation = -S12 (dB)

Output Return Loss = -S22 (dB)

TEST CONDITIONS: Vd = 4.75V, Id = 95.44mA @ Temperature = +25°C

FREQ	Gain	Isolation	Input Return Loss	Output Return Loss	Stability		IP-3 Output	1dB Comp. Output	Noise Figure
					K	Measure			
(MHz)	(dB)	(dB)	(dB)	(dB)	K	Measure	(dBm)	(dBm)	(dB)
10	24.30	31.26	26.76	21.38	1.32	0.80	36.50	19.35	5.17
50	24.30	31.23	26.84	20.84	1.32	0.79	35.56	19.90	4.93
100	24.28	31.22	26.51	20.24	1.32	0.79	36.41	19.76	4.91
200	24.20	31.15	25.37	18.25	1.31	0.79	35.84	19.91	4.92
300	24.10	31.04	23.91	16.31	1.30	0.79	35.65	19.89	4.91
400	23.96	30.89	22.60	14.57	1.28	0.78	34.69	19.87	4.93
500	23.80	30.73	21.40	13.15	1.26	0.77	34.83	19.95	4.91
600	23.61	30.53	20.37	11.96	1.23	0.76	35.06	19.90	4.95
700	23.41	30.32	19.41	10.98	1.21	0.75	34.57	19.86	5.03
800	23.18	30.11	18.62	10.16	1.18	0.74	34.39	19.78	5.00
900	22.95	29.89	18.01	9.46	1.16	0.73	34.14	19.79	5.01
1000	22.69	29.66	17.47	8.87	1.14	0.72	33.52	19.89	5.04
1250	22.04	29.11	16.46	7.77	1.10	0.69	33.36	19.69	5.09
1500	21.36	28.57	15.81	7.04	1.07	0.68	32.57	19.82	5.15
1750	20.70	28.05	15.41	6.54	1.04	0.66	32.52	19.86	5.20
2000	20.05	27.54	15.19	6.23	1.03	0.65	32.45	19.95	5.20
2250	19.43	27.06	15.06	6.01	1.03	0.65	32.67	19.73	5.23
2500	18.85	26.56	15.01	5.89	1.02	0.64	33.01	19.37	5.24
2750	18.29	26.09	14.98	5.84	1.03	0.64	32.06	19.80	5.31
3000	17.76	25.63	14.99	5.83	1.03	0.64	31.77	19.87	5.26
3250	17.26	25.17	14.97	5.85	1.04	0.64	31.79	19.68	5.41
3500	16.75	24.75	15.05	5.87	1.05	0.65	32.13	19.36	5.35
3750	16.26	24.35	15.05	5.89	1.06	0.65	31.66	19.07	5.39
4000	15.76	23.97	15.07	5.87	1.08	0.65	30.55	19.01	5.38
4250	15.28	23.62	15.12	5.88	1.09	0.65	30.48	18.91	5.50
4500	14.80	23.28	15.09	5.88	1.11	0.65	29.96	18.60	5.50
4750	14.32	22.98	14.99	5.87	1.13	0.64	29.98	18.29	5.55
5000	13.83	22.68	14.75	5.85	1.16	0.64	29.39	17.97	5.66
5250	13.34	22.44	14.42	5.78	1.18	0.64	29.52	17.58	5.67
5500	12.83	22.21	14.12	5.73	1.21	0.64	29.37	17.08	5.74
5750	12.33	22.01	13.76	5.65	1.24	0.64	29.01	16.76	5.82
6000	11.82	21.83	13.38	5.61	1.27	0.65	28.96	16.33	5.86
6250	11.31	21.67	13.01	5.54	1.31	0.65	28.85	15.90	5.93
6500	10.81	21.52	12.58	5.47	1.34	0.65	28.23	15.61	6.04
6750	10.32	21.38	12.21	5.41	1.38	0.65	28.12	15.19	6.14
7000	9.82	21.26	11.85	5.35	1.42	0.66	27.15	14.96	6.22
7250	9.34	21.13	11.52	5.32	1.46	0.66	27.39	14.54	6.28
7500	8.86	21.01	11.18	5.31	1.50	0.67	26.43	14.29	6.39

## Typical Performance Data

### Definitions:

Input Return Loss = -S11 (dB)

Gain(Power Gain) = S21 (dB)

Reverse Isolation = -S12 (dB)

Output Return Loss = -S22 (dB)

TEST CONDITIONS: Vd = 5.25V, Id = 123.97mA @ Temperature = +25°C

FREQ	Gain	Isolation	Input Return Loss	Output Return Loss	Stability		IP-3 Output	1dB Comp. Output	Noise Figure
					K	Measure			
(MHz)	(dB)	(dB)	(dB)	(dB)	K	Measure	(dBm)	(dBm)	(dB)
10	24.53	31.62	23.58	24.20	1.34	0.81	38.64	21.07	5.34
50	24.55	31.56	23.64	23.35	1.33	0.80	40.12	21.83	5.13
100	24.52	31.56	23.46	22.29	1.33	0.81	41.24	21.64	5.11
200	24.44	31.49	22.91	19.38	1.32	0.80	39.19	21.88	5.15
300	24.33	31.39	22.14	16.96	1.31	0.80	40.07	21.86	5.10
400	24.19	31.25	21.29	14.97	1.29	0.79	38.28	21.85	5.10
500	24.03	31.08	20.46	13.41	1.27	0.78	38.76	21.94	5.11
600	23.84	30.90	19.69	12.13	1.25	0.77	38.33	21.92	5.15
700	23.62	30.69	18.91	11.11	1.23	0.76	37.33	21.91	5.21
800	23.40	30.48	18.28	10.26	1.20	0.74	37.17	21.85	5.17
900	23.16	30.26	17.77	9.53	1.18	0.73	37.14	21.81	5.21
1000	22.90	30.04	17.29	8.93	1.16	0.72	36.31	21.90	5.23
1250	22.23	29.49	16.41	7.81	1.12	0.70	36.01	21.78	5.27
1500	21.54	28.94	15.86	7.07	1.09	0.68	35.03	21.81	5.34
1750	20.87	28.42	15.50	6.57	1.07	0.66	35.10	21.87	5.40
2000	20.21	27.90	15.33	6.25	1.06	0.65	34.91	22.08	5.41
2250	19.58	27.40	15.24	6.03	1.05	0.64	35.08	21.93	5.45
2500	18.99	26.89	15.22	5.91	1.05	0.64	35.23	21.64	5.44
2750	18.43	26.40	15.22	5.85	1.05	0.64	33.86	21.49	5.50
3000	17.89	25.91	15.24	5.83	1.06	0.64	33.58	21.58	5.49
3250	17.39	25.45	15.22	5.84	1.06	0.64	33.53	21.31	5.61
3500	16.88	25.00	15.31	5.86	1.07	0.64	33.84	21.03	5.60
3750	16.39	24.59	15.31	5.86	1.08	0.64	33.38	20.59	5.59
4000	15.89	24.19	15.33	5.84	1.09	0.64	31.94	20.35	5.60
4250	15.42	23.83	15.35	5.83	1.10	0.64	32.24	20.24	5.75
4500	14.94	23.47	15.30	5.81	1.12	0.64	31.44	19.83	5.75
4750	14.46	23.16	15.18	5.79	1.14	0.64	31.44	19.52	5.77
5000	13.98	22.84	14.91	5.74	1.16	0.63	30.94	19.13	5.88
5250	13.49	22.58	14.57	5.66	1.18	0.63	30.84	18.73	5.94
5500	12.99	22.35	14.22	5.59	1.20	0.63	30.86	18.24	5.98
5750	12.50	22.13	13.84	5.50	1.22	0.63	30.41	17.89	6.05
6000	12.00	21.94	13.45	5.43	1.25	0.63	30.35	17.46	6.12
6250	11.50	21.77	13.04	5.36	1.28	0.63	30.15	17.04	6.25
6500	11.01	21.60	12.61	5.26	1.31	0.63	29.66	16.71	6.33
6750	10.52	21.46	12.23	5.19	1.34	0.63	29.57	16.30	6.44
7000	10.03	21.33	11.85	5.12	1.38	0.63	28.55	16.01	6.49
7250	9.55	21.19	11.51	5.08	1.41	0.64	28.87	15.60	6.57
7500	9.08	21.07	11.16	5.04	1.45	0.65	27.84	15.35	6.69



## Typical Performance Data

### Definitions:

Input Return Loss = -S11 (dB)

Gain(Power Gain) = S21 (dB)

Reverse Isolation = -S12 (dB)

Output Return Loss = -S22 (dB)

TEST CONDITIONS: Vd = 5.00V, Id = 104.49mA @ Temperature = -45°C

FREQ	Gain	Isolation	Input Return Loss	Output Return Loss	Stability		IP-3 Output	1dB Comp. Output	Noise Figure
					K	Measure			
(MHz)	(dB)	(dB)	(dB)	(dB)	K	Measure	(dBm)	(dBm)	(dB)
10	24.55	31.68	24.21	23.65	1.34	0.81	41.08	20.20	4.63
50	24.56	31.59	24.05	22.62	1.33	0.80	38.54	20.79	4.46
100	24.54	31.58	24.13	21.49	1.33	0.80	40.34	20.67	4.44
200	24.47	31.50	23.73	18.86	1.32	0.80	38.14	20.85	4.44
300	24.36	31.37	22.43	16.79	1.31	0.79	40.06	20.84	4.43
400	24.23	31.22	21.24	15.00	1.29	0.79	37.18	20.82	4.42
500	24.07	31.04	20.43	13.43	1.26	0.78	37.01	20.90	4.42
600	23.89	30.84	19.67	12.12	1.24	0.76	36.85	20.87	4.42
700	23.68	30.63	18.77	11.09	1.22	0.75	37.17	20.84	4.53
800	23.46	30.41	18.02	10.29	1.19	0.74	35.95	20.76	4.46
900	23.24	30.18	17.54	9.59	1.17	0.73	35.96	20.76	4.52
1000	22.99	29.95	17.11	8.95	1.15	0.72	35.08	20.86	4.54
1250	22.33	29.40	16.17	7.77	1.10	0.69	34.94	20.65	4.56
1500	21.69	28.83	15.69	7.07	1.07	0.67	34.20	20.81	4.61
1750	21.03	28.32	15.28	6.50	1.05	0.65	34.07	20.87	4.69
2000	20.39	27.80	15.10	6.18	1.04	0.64	34.01	20.93	4.67
2250	19.78	27.32	15.04	5.93	1.03	0.63	34.50	20.67	4.74
2500	19.23	26.81	14.96	5.85	1.02	0.62	34.75	20.42	4.72
2750	18.66	26.34	15.08	5.69	1.02	0.62	33.30	20.81	4.75
3000	18.17	25.86	15.22	5.73	1.03	0.62	33.04	20.93	4.75
3250	17.69	25.40	15.39	5.68	1.03	0.61	33.03	20.77	4.89
3500	17.23	24.93	15.55	5.72	1.03	0.61	33.57	20.50	4.81
3750	16.77	24.52	15.53	5.65	1.04	0.61	32.81	20.12	4.86
4000	16.30	24.14	15.82	5.59	1.05	0.60	31.83	20.16	4.82
4250	15.86	23.75	15.70	5.52	1.05	0.59	31.99	20.14	4.98
4500	15.41	23.40	15.64	5.48	1.06	0.59	31.39	19.84	4.96
4750	14.95	23.10	15.39	5.40	1.07	0.58	31.43	19.58	5.00
5000	14.49	22.79	15.14	5.30	1.08	0.58	30.88	19.24	5.09
5250	14.02	22.53	14.71	5.20	1.10	0.57	31.01	18.89	5.14
5500	13.56	22.29	14.31	5.15	1.12	0.57	30.86	18.38	5.17
5750	13.11	22.04	13.89	5.07	1.13	0.57	30.56	18.09	5.27
6000	12.66	21.82	13.58	5.07	1.15	0.58	30.68	17.69	5.31
6250	12.21	21.61	13.23	5.02	1.17	0.58	30.56	17.27	5.41
6500	11.76	21.43	12.82	4.96	1.19	0.58	29.96	16.99	5.46
6750	11.32	21.24	12.49	4.89	1.21	0.58	30.05	16.57	5.56
7000	10.85	21.11	12.23	4.79	1.24	0.58	28.94	16.33	5.59
7250	10.39	20.96	11.85	4.67	1.26	0.57	29.07	15.88	5.66
7500	9.93	20.86	11.40	4.57	1.28	0.57	28.27	15.61	5.76

## Typical Performance Data

### Definitions:

Input Return Loss = -S11 (dB)

Gain(Power Gain) = S21 (dB)

Reverse Isolation = -S12 (dB)

Output Return Loss = -S22 (dB)

TEST CONDITIONS: Vd = 4.75V, Id = 91.75mA @ Temperature = -45°C

FREQ	Gain	Isolation	Input Return Loss	Output Return Loss	Stability		IP-3 Output	1dB Comp. Output	Noise Figure
					K	Measure			
(MHz)	(dB)	(dB)	(dB)	(dB)	K	Measure	(dBm)	(dBm)	(dB)
10	24.44	31.48	25.76	22.19	1.33	0.80	43.65	19.26	4.51
50	24.44	31.42	25.58	21.36	1.32	0.80	36.09	19.72	4.37
100	24.42	31.40	25.71	20.49	1.32	0.80	37.62	19.64	4.34
200	24.34	31.32	25.07	18.29	1.31	0.79	36.28	19.75	4.36
300	24.24	31.20	23.40	16.46	1.30	0.79	35.69	19.73	4.30
400	24.11	31.04	21.90	14.80	1.28	0.78	35.40	19.69	4.35
500	23.96	30.86	20.93	13.31	1.26	0.77	34.96	19.77	4.28
600	23.78	30.66	20.07	12.04	1.23	0.76	35.06	19.71	4.35
700	23.57	30.44	19.07	11.04	1.21	0.75	34.49	19.64	4.42
800	23.36	30.22	18.25	10.25	1.18	0.74	34.59	19.54	4.40
900	23.13	29.98	17.69	9.55	1.16	0.73	34.47	19.58	4.44
1000	22.89	29.75	17.25	8.93	1.14	0.71	33.45	19.69	4.45
1250	22.24	29.21	16.22	7.75	1.09	0.69	33.44	19.45	4.47
1500	21.61	28.64	15.70	7.06	1.06	0.67	32.88	19.66	4.55
1750	20.95	28.13	15.28	6.49	1.04	0.65	32.75	19.67	4.70
2000	20.32	27.63	15.07	6.17	1.02	0.64	32.68	19.67	4.60
2250	19.71	27.15	15.00	5.92	1.02	0.63	32.89	19.35	4.64
2500	19.16	26.65	14.89	5.84	1.01	0.62	33.42	19.08	4.60
2750	18.60	26.20	14.99	5.69	1.01	0.62	32.01	19.78	4.68
3000	18.11	25.72	15.12	5.72	1.01	0.62	32.11	19.82	4.66
3250	17.63	25.27	15.27	5.68	1.02	0.61	32.12	19.74	4.80
3500	17.18	24.81	15.46	5.72	1.02	0.61	32.49	19.45	4.72
3750	16.71	24.40	15.41	5.65	1.03	0.61	31.96	19.25	4.74
4000	16.24	24.04	15.71	5.61	1.04	0.60	30.81	19.33	4.71
4250	15.80	23.65	15.59	5.53	1.04	0.59	30.93	19.29	4.87
4500	15.35	23.31	15.54	5.51	1.06	0.59	30.45	19.05	4.87
4750	14.88	23.01	15.31	5.43	1.07	0.59	30.53	18.76	4.88
5000	14.42	22.72	15.08	5.34	1.08	0.58	29.94	18.51	5.01
5250	13.95	22.46	14.65	5.24	1.10	0.58	30.01	18.14	5.03
5500	13.49	22.22	14.27	5.21	1.12	0.58	29.96	17.62	5.04
5750	13.03	21.99	13.87	5.13	1.13	0.58	29.69	17.36	5.14
6000	12.58	21.77	13.57	5.14	1.16	0.58	29.65	16.95	5.16
6250	12.13	21.56	13.21	5.10	1.18	0.59	29.58	16.51	5.28
6500	11.67	21.38	12.82	5.05	1.20	0.59	28.95	16.27	5.37
6750	11.22	21.21	12.51	4.99	1.23	0.59	28.83	15.84	5.46
7000	10.75	21.08	12.22	4.89	1.25	0.59	27.91	15.66	5.49
7250	10.29	20.94	11.87	4.78	1.28	0.59	28.09	15.19	5.51
7500	9.82	20.83	11.41	4.68	1.30	0.59	27.30	14.97	5.63

## Typical Performance Data

### Definitions:

Input Return Loss = -S11 (dB)

Gain(Power Gain) = S21 (dB)

Reverse Isolation = -S12 (dB)

Output Return Loss = -S22 (dB)

TEST CONDITIONS: Vd = 5.25V, Id = 117.81mA @ Temperature = -45°C

FREQ	Gain	Isolation	Input Return Loss	Output Return Loss	Stability		IP-3 Output	1dB Comp. Output	Noise Figure
					K	Measure			
(MHz)	(dB)	(dB)	(dB)	(dB)	K	Measure	(dBm)	(dBm)	(dB)
10	24.64	31.81	22.99	24.91	1.35	0.81	41.10	21.03	4.69
50	24.65	31.73	23.00	23.66	1.34	0.81	40.37	21.72	4.53
100	24.63	31.71	23.09	22.29	1.33	0.81	43.29	21.56	4.50
200	24.56	31.64	22.87	19.26	1.33	0.80	41.08	21.79	4.54
300	24.45	31.51	21.74	17.02	1.31	0.80	40.64	21.78	4.50
400	24.32	31.36	20.73	15.14	1.29	0.79	40.08	21.77	4.50
500	24.16	31.18	20.05	13.53	1.27	0.78	39.11	21.85	4.53
600	23.97	30.99	19.36	12.18	1.25	0.77	38.50	21.84	4.53
700	23.77	30.78	18.52	11.14	1.22	0.75	38.22	21.80	4.58
800	23.55	30.56	17.85	10.33	1.20	0.74	37.39	21.75	4.57
900	23.32	30.33	17.40	9.62	1.18	0.73	37.31	21.73	4.59
1000	23.07	30.10	17.01	8.98	1.16	0.72	36.27	21.83	4.62
1250	22.41	29.55	16.10	7.79	1.11	0.69	36.38	21.64	4.65
1500	21.76	28.99	15.66	7.09	1.08	0.67	35.25	21.79	4.71
1750	21.10	28.46	15.28	6.52	1.06	0.65	34.99	21.79	4.78
2000	20.46	27.95	15.13	6.20	1.05	0.64	35.08	21.98	4.74
2250	19.84	27.45	15.08	5.95	1.04	0.63	35.25	21.77	4.82
2500	19.29	26.93	15.00	5.86	1.03	0.62	35.84	21.53	4.81
2750	18.72	26.47	15.13	5.71	1.03	0.61	34.20	21.63	4.85
3000	18.23	25.97	15.28	5.74	1.03	0.62	34.14	21.79	4.83
3250	17.75	25.51	15.46	5.69	1.04	0.61	34.08	21.57	4.95
3500	17.29	25.03	15.65	5.72	1.04	0.61	34.45	21.31	4.89
3750	16.82	24.62	15.62	5.65	1.04	0.60	33.73	20.89	4.92
4000	16.35	24.24	15.91	5.59	1.05	0.60	32.66	20.82	4.90
4250	15.92	23.83	15.77	5.51	1.05	0.59	32.67	20.80	5.03
4500	15.47	23.48	15.68	5.47	1.06	0.59	32.20	20.44	5.08
4750	15.01	23.17	15.43	5.38	1.08	0.58	32.24	20.19	5.10
5000	14.55	22.86	15.18	5.28	1.09	0.57	31.66	19.81	5.20
5250	14.09	22.60	14.72	5.17	1.10	0.57	31.82	19.45	5.20
5500	13.63	22.34	14.33	5.11	1.11	0.57	31.71	18.96	5.26
5750	13.18	22.10	13.90	5.02	1.12	0.57	31.34	18.65	5.35
6000	12.74	21.87	13.59	5.01	1.14	0.57	31.57	18.25	5.41
6250	12.29	21.65	13.23	4.96	1.16	0.57	31.43	17.84	5.49
6500	11.85	21.46	12.81	4.89	1.18	0.57	30.87	17.54	5.60
6750	11.41	21.28	12.48	4.82	1.20	0.57	30.80	17.13	5.66
7000	10.94	21.14	12.21	4.71	1.22	0.57	29.77	16.85	5.72
7250	10.49	20.99	11.84	4.59	1.24	0.56	30.05	16.40	5.75
7500	10.02	20.88	11.37	4.47	1.27	0.56	29.13	16.11	5.86

## Typical Performance Data

### Definitions:

Input Return Loss = -S11 (dB)

Gain(Power Gain) = S21 (dB)

Reverse Isolation = -S12 (dB)

Output Return Loss = -S22 (dB)

TEST CONDITIONS: Vd = 5.00V, Id = 114.59mA @ Temperature = +85°C

FREQ	Gain	Isolation	Input Return Loss	Output Return Loss	Stability		IP-3 Output	1dB Comp. Output	Noise Figure
					K	Measure			
(MHz)	(dB)	(dB)	(dB)	(dB)			(dBm)	(dBm)	(dB)
10	24.33	31.32	25.69	22.30	1.33	0.80	36.43	20.31	5.78
50	24.34	31.26	25.55	21.89	1.32	0.80	37.57	21.03	5.59
100	24.31	31.26	24.84	21.41	1.32	0.80	38.37	20.84	5.56
200	24.23	31.20	23.23	19.12	1.31	0.80	38.08	21.04	5.61
300	24.11	31.10	22.42	16.59	1.30	0.79	37.34	21.03	5.47
400	23.96	30.97	21.99	14.49	1.28	0.78	37.68	21.02	5.53
500	23.79	30.81	21.17	12.97	1.26	0.77	37.52	21.10	5.57
600	23.59	30.63	20.12	11.81	1.24	0.76	36.99	21.08	5.56
700	23.36	30.42	19.16	10.87	1.22	0.75	36.91	21.05	5.66
800	23.13	30.22	18.51	10.05	1.20	0.74	36.38	20.99	5.60
900	22.88	30.00	17.99	9.35	1.17	0.73	36.14	20.97	5.65
1000	22.62	29.77	17.50	8.79	1.15	0.72	35.42	21.07	5.64
1250	21.94	29.21	16.57	7.75	1.11	0.70	35.34	20.95	5.71
1500	21.25	28.65	15.93	7.07	1.08	0.69	34.11	21.00	5.78
1750	20.56	28.11	15.53	6.59	1.06	0.67	34.17	21.06	5.89
2000	19.88	27.59	15.29	6.28	1.05	0.66	33.91	21.22	5.86
2250	19.22	27.09	15.13	6.07	1.05	0.66	34.07	21.05	5.94
2500	18.60	26.60	14.97	5.96	1.05	0.66	34.28	20.73	5.91
2750	18.00	26.12	14.86	5.92	1.06	0.66	32.95	20.55	5.98
3000	17.42	25.66	14.81	5.93	1.07	0.66	32.65	20.58	5.98
3250	16.86	25.22	14.72	5.97	1.08	0.67	32.43	20.26	6.13
3500	16.30	24.81	14.73	6.00	1.10	0.67	32.59	19.92	6.07
3750	15.75	24.42	14.69	6.04	1.12	0.68	31.90	19.47	6.15
4000	15.20	24.07	14.74	6.07	1.15	0.68	30.72	19.19	6.16
4250	14.68	23.71	14.73	6.11	1.17	0.68	30.44	18.97	6.29
4500	14.16	23.38	14.71	6.19	1.20	0.69	29.89	18.57	6.29
4750	13.64	23.08	14.62	6.26	1.23	0.69	29.69	18.20	6.37
5000	13.13	22.78	14.43	6.31	1.27	0.70	29.16	17.84	6.47
5250	12.61	22.53	14.16	6.30	1.30	0.70	29.09	17.40	6.51
5500	12.08	22.31	13.87	6.26	1.34	0.70	28.89	16.95	6.55
5750	11.54	22.12	13.53	6.16	1.38	0.70	28.47	16.59	6.69
6000	10.99	21.95	13.16	6.04	1.42	0.70	28.28	16.14	6.76
6250	10.43	21.81	12.70	5.91	1.46	0.70	28.04	15.72	6.87
6500	9.89	21.70	12.25	5.81	1.51	0.70	27.58	15.40	6.97
6750	9.35	21.57	11.74	5.72	1.56	0.70	27.44	15.01	7.10
7000	8.82	21.47	11.29	5.68	1.61	0.71	26.56	14.75	7.18
7250	8.32	21.35	10.89	5.68	1.66	0.72	26.75	14.33	7.28
7500	7.83	21.23	10.52	5.73	1.71	0.73	25.80	14.12	7.43

## Typical Performance Data

### Definitions:

Input Return Loss = -S11 (dB)

Gain(Power Gain) = S21 (dB)

Reverse Isolation = -S12 (dB)

Output Return Loss = -S22 (dB)

TEST CONDITIONS: Vd = 4.75V, Id = 99.40mA @ Temperature = +85°C

FREQ	Gain	Isolation	Input Return Loss	Output Return Loss	Stability		IP-3 Output	1dB Comp. Output	Noise Figure
					K	Measure			
(MHz)	(dB)	(dB)	(dB)	(dB)	K	Measure	(dBm)	(dBm)	(dB)
10	24.18	31.11	28.02	20.80	1.32	0.79	35.17	19.42	5.69
50	24.18	31.07	27.82	20.46	1.32	0.79	36.05	20.04	5.46
100	24.16	31.06	26.85	20.18	1.32	0.79	37.25	19.86	5.41
200	24.08	31.00	24.54	18.44	1.31	0.79	35.77	20.03	5.45
300	23.96	30.90	23.40	16.22	1.29	0.79	35.64	20.00	5.39
400	23.82	30.76	22.66	14.26	1.28	0.78	35.74	19.99	5.42
500	23.65	30.60	21.66	12.82	1.26	0.77	35.34	20.07	5.47
600	23.45	30.41	20.44	11.71	1.23	0.76	35.42	20.03	5.44
700	23.23	30.21	19.34	10.80	1.21	0.75	35.02	20.00	5.52
800	23.00	29.99	18.61	10.00	1.18	0.74	34.70	19.92	5.49
900	22.76	29.77	18.03	9.32	1.16	0.73	34.47	19.93	5.53
1000	22.50	29.55	17.50	8.76	1.14	0.72	34.05	20.02	5.55
1250	21.83	28.98	16.51	7.74	1.10	0.70	33.64	19.84	5.60
1500	21.15	28.43	15.84	7.06	1.06	0.69	33.15	19.97	5.68
1750	20.47	27.90	15.42	6.58	1.04	0.67	32.68	20.02	5.75
2000	19.80	27.39	15.15	6.27	1.03	0.66	32.60	20.12	5.71
2250	19.15	26.89	14.97	6.07	1.03	0.66	32.77	19.95	5.79
2500	18.52	26.41	14.80	5.96	1.03	0.66	33.12	19.60	5.81
2750	17.93	25.94	14.70	5.92	1.04	0.66	31.89	19.71	5.84
3000	17.35	25.49	14.63	5.94	1.05	0.67	31.61	19.74	5.85
3250	16.80	25.06	14.56	5.98	1.07	0.67	31.48	19.46	6.02
3500	16.24	24.66	14.57	6.02	1.09	0.67	31.65	19.11	5.93
3750	15.69	24.28	14.54	6.06	1.11	0.68	31.10	18.72	6.00
4000	15.14	23.94	14.59	6.11	1.14	0.68	30.06	18.53	6.04
4250	14.62	23.59	14.59	6.16	1.16	0.69	29.83	18.33	6.13
4500	14.09	23.27	14.60	6.24	1.20	0.69	29.19	17.97	6.15
4750	13.58	22.98	14.50	6.32	1.23	0.70	29.13	17.61	6.21
5000	13.06	22.69	14.32	6.39	1.27	0.70	28.61	17.26	6.28
5250	12.54	22.45	14.07	6.39	1.30	0.71	28.43	16.84	6.34
5500	12.00	22.24	13.80	6.36	1.35	0.71	28.36	16.39	6.41
5750	11.47	22.05	13.47	6.26	1.38	0.71	27.85	16.02	6.49
6000	10.91	21.90	13.11	6.15	1.43	0.71	27.75	15.59	6.57
6250	10.35	21.76	12.67	6.03	1.48	0.71	27.54	15.16	6.68
6500	9.81	21.65	12.24	5.94	1.53	0.71	26.93	14.86	6.76
6750	9.26	21.54	11.73	5.85	1.58	0.71	26.84	14.46	6.89
7000	8.73	21.43	11.28	5.82	1.63	0.72	25.95	14.24	6.94
7250	8.23	21.32	10.90	5.83	1.68	0.73	26.18	13.83	7.08
7500	7.74	21.21	10.52	5.88	1.74	0.75	25.25	13.53	7.21

## Typical Performance Data

### Definitions:

Input Return Loss = -S11 (dB)

Gain(Power Gain) = S21 (dB)

Reverse Isolation = -S12 (dB)

Output Return Loss = -S22 (dB)

TEST CONDITIONS: Vd = 5.25V, Id = 132.14mA @ Temperature = +85°C

FREQ	Gain	Isolation	Input Return Loss	Output Return Loss	Stability		IP-3 Output	1dB Comp. Output	Noise Figure
					K	Measure			
(MHz)	(dB)	(dB)	(dB)	(dB)	K	Measure	(dBm)	(dBm)	(dB)
10	24.44	31.48	24.16	23.68	1.33	0.81	38.97	21.17	5.86
50	24.45	31.43	24.01	23.23	1.33	0.80	40.00	21.99	5.70
100	24.42	31.43	23.43	22.50	1.33	0.80	42.43	21.76	5.67
200	24.34	31.37	22.16	19.66	1.32	0.80	41.86	22.00	5.67
300	24.22	31.28	21.60	16.87	1.31	0.80	41.91	21.97	5.60
400	24.07	31.14	21.38	14.66	1.29	0.79	39.64	21.95	5.66
500	23.89	30.99	20.72	13.09	1.27	0.78	39.27	22.03	5.68
600	23.69	30.81	19.81	11.89	1.25	0.77	39.28	22.02	5.68
700	23.47	30.61	18.96	10.92	1.23	0.76	38.42	22.01	5.77
800	23.23	30.40	18.37	10.09	1.21	0.75	37.76	21.95	5.72
900	22.98	30.19	17.92	9.38	1.18	0.74	37.91	21.91	5.78
1000	22.71	29.96	17.46	8.82	1.16	0.73	37.05	21.98	5.82
1250	22.03	29.39	16.59	7.77	1.12	0.70	36.94	21.90	5.84
1500	21.33	28.84	16.01	7.09	1.09	0.69	35.62	21.87	5.90
1750	20.64	28.29	15.62	6.60	1.07	0.67	35.14	21.92	6.00
2000	19.95	27.76	15.40	6.29	1.06	0.66	35.13	22.12	5.94
2250	19.29	27.25	15.22	6.08	1.06	0.66	34.54	22.01	6.03
2500	18.66	26.75	15.07	5.97	1.06	0.66	34.83	21.72	6.07
2750	18.05	26.26	14.97	5.92	1.07	0.66	33.65	21.28	6.11
3000	17.47	25.79	14.91	5.93	1.08	0.66	33.31	21.28	6.10
3250	16.91	25.35	14.83	5.97	1.09	0.67	32.89	20.93	6.25
3500	16.34	24.92	14.83	6.00	1.11	0.67	32.97	20.59	6.18
3750	15.79	24.53	14.80	6.03	1.13	0.67	32.29	20.08	6.26
4000	15.24	24.17	14.83	6.06	1.16	0.68	31.30	19.74	6.24
4250	14.72	23.80	14.80	6.10	1.18	0.68	31.00	19.49	6.42
4500	14.20	23.47	14.80	6.16	1.21	0.69	30.33	19.07	6.46
4750	13.68	23.16	14.68	6.23	1.24	0.69	30.11	18.68	6.49
5000	13.17	22.85	14.48	6.28	1.27	0.69	29.58	18.31	6.61
5250	12.65	22.59	14.20	6.26	1.30	0.70	29.44	17.87	6.67
5500	12.12	22.37	13.90	6.21	1.34	0.70	29.33	17.42	6.71
5750	11.59	22.17	13.53	6.10	1.38	0.70	28.86	17.04	6.85
6000	11.04	22.00	13.17	5.99	1.42	0.69	28.63	16.60	6.90
6250	10.48	21.85	12.69	5.85	1.46	0.69	28.43	16.17	7.05
6500	9.94	21.73	12.23	5.75	1.50	0.69	27.93	15.85	7.14
6750	9.40	21.61	11.73	5.65	1.55	0.70	27.80	15.41	7.28
7000	8.87	21.49	11.27	5.61	1.60	0.70	26.95	15.19	7.37
7250	8.37	21.37	10.88	5.60	1.65	0.71	27.09	14.83	7.47
7500	7.88	21.25	10.50	5.64	1.70	0.73	26.21	14.56	7.62



## Typical Performance Curves

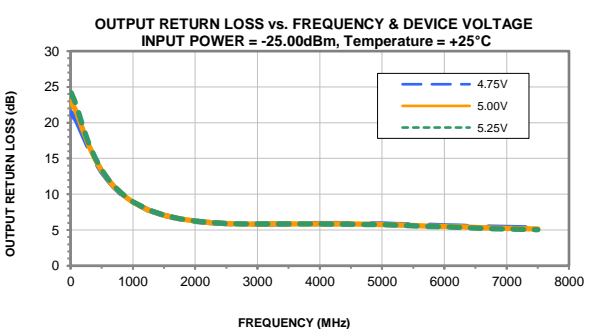
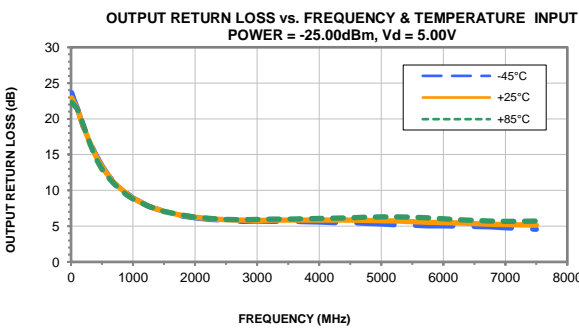
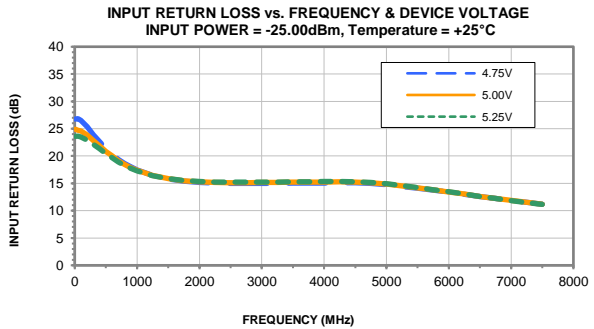
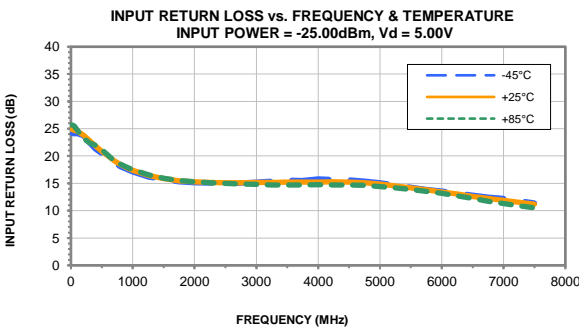
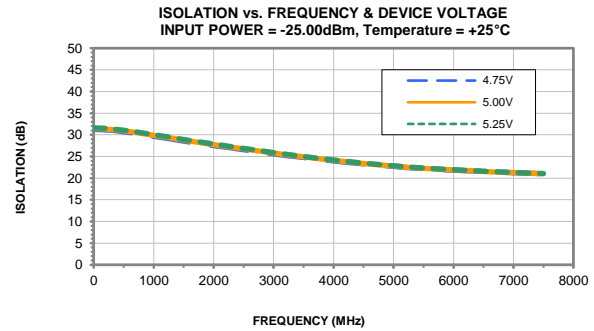
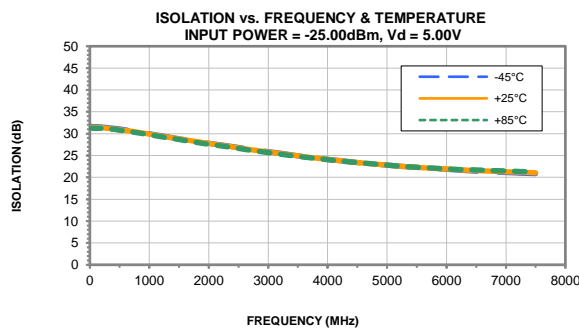
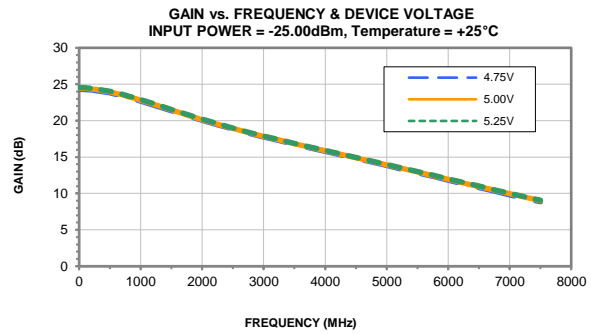
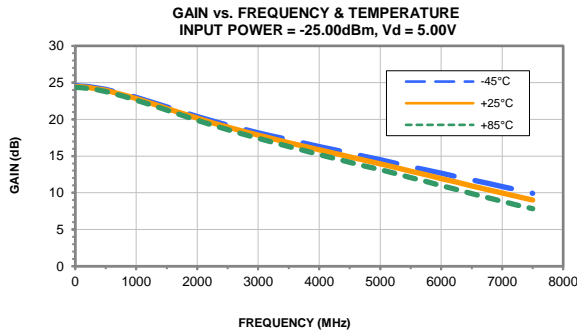

## Typical Performance Curves

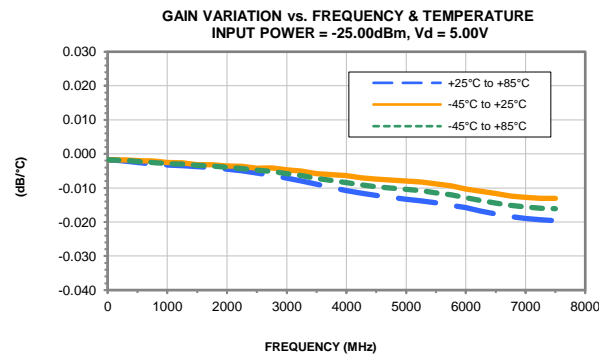
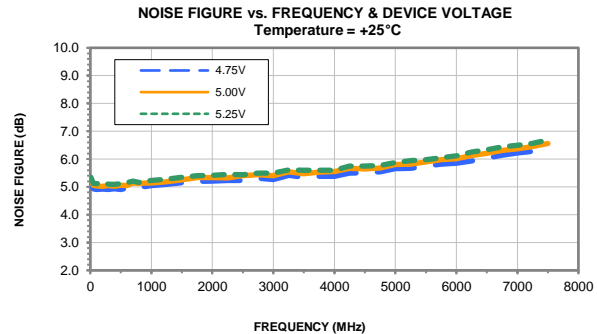
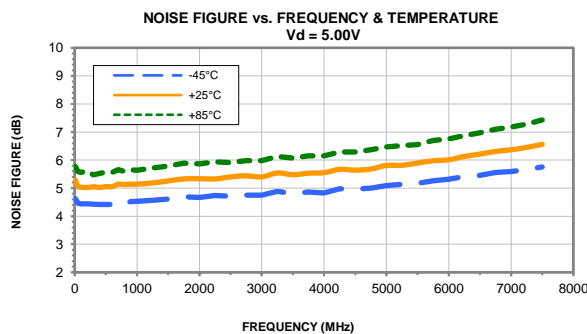
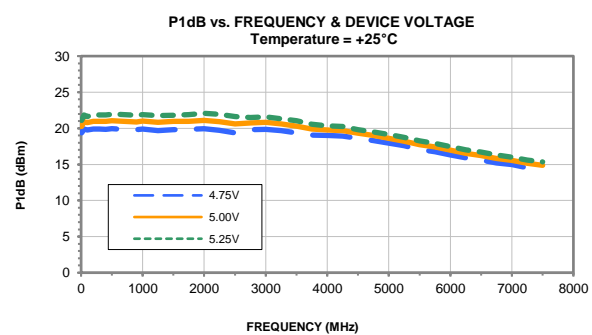
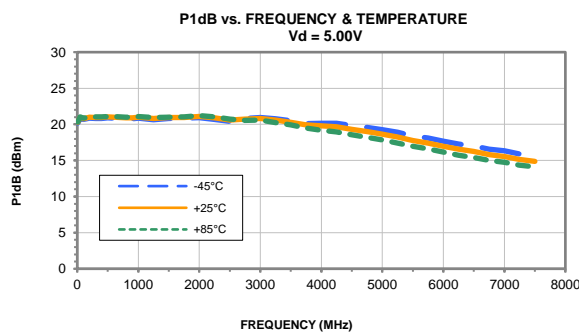
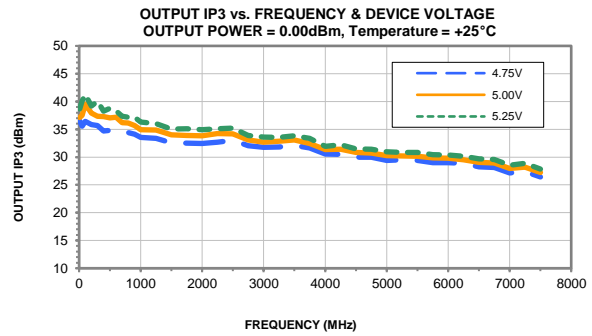
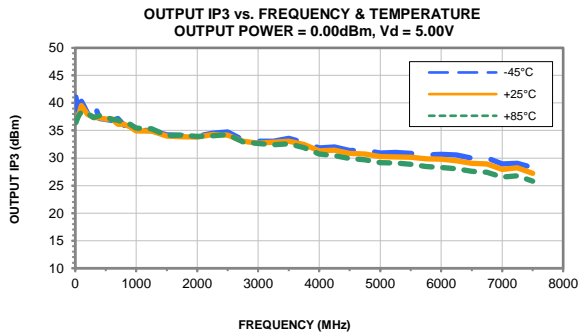



### Outline Dimensions

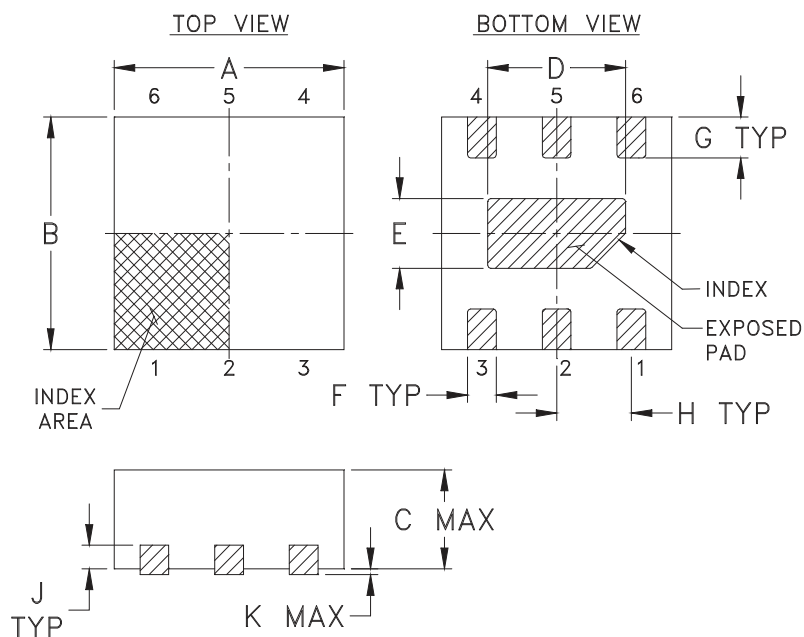

### PCB Land Pattern

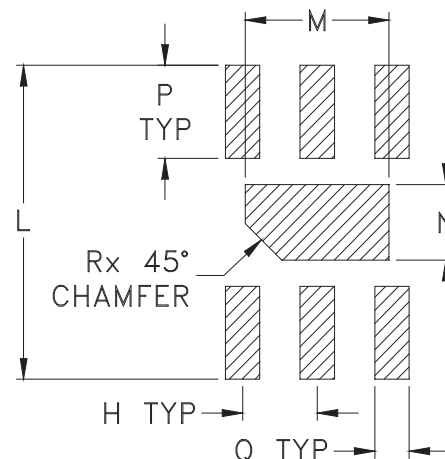

Suggested Layout,  
Tolerance to be within  $\pm .002$

CASE #.	A	B	C	D	E	F	G	H	J	K	L	M	N	P
MC1630-1	.079 (2.00)	.079 (2.00)	.039 (1.00)	.047 (1.20)	.024 (.60)	.010 (.25)	.014 (.35)	.026 (.65)	.008 (.20)	.002 (.05)	.106 (2.70)	.049 (1.25)	.026 (.65)	.031 (.80)

CASE #.	Q	R	WT, GRAM
MC1630-1	.012 (.30)	.012 (.30)	.006

Dimensions are in inches (mm). Tolerances: 2 Pl.  $\pm .01$ ; 3 Pl.  $\pm .005$

#### Notes:

- Case material: Plastic.
- Termination finish:  
For RoHS Case Styles: Tin-Silver over Nickel plated or Matte-Tin plated (See Data sheet).  
All models, (+) suffix.
- Lead #1 identifier shall be located in the cross-hatched area shown.  
Identifier may be either a molded or marked feature.



P.O. Box 350166, Brooklyn, New York 11235-0003 (718) 934-4500 Fax (718) 332-4661 For detailed performance specs & shopping online see Mini-Circuits web site



The Design Engineers Search Engine Provides ACTUAL Data Instantly From MINI-CIRCUITS At: [www.minicircuits.com](http://www.minicircuits.com)

RF/IF MICROWAVE COMPONENTS

# Tape & Reel Packaging TR-F66



Tape Width, mm	Device Cavity Pitch, mm	Reel Size, inches	Devices per Reel see note	
8	4	7	Small quantity standard	20
				50
				100
				200
				500
		7	Standard	1000, 2000, 3000

Note: Please consult individual model data sheet to determine device per reel availability.

Mini-Circuits carrier tape materials provide protection from ESD (Electro-Static Discharge) during handling and transportation. Tapes are static dissipative and comply with industry standards EIA-481/EIA-541.

Go to: [www.minicircuits.com/pages/pdfs/tape.pdf](http://www.minicircuits.com/pages/pdfs/tape.pdf)

**Mini-Circuits®**

INTERNET <http://www.minicircuits.com>

P.O. Box 350166, Brooklyn, New York 11235-0003 (718) 934-4500 Fax (718) 332-4661

Distribution Centers NORTH AMERICA 800-654-7949 • 417-335-5935 • Fax 417-335-5945 • EUROPE 44-1252-832600 • Fax 44-1252-837010

Mini-Circuits ISO 9001 & ISO 14001 Certified

THIRD ANGLE PROJECTION

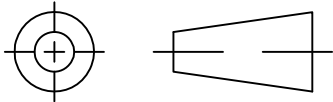

REVISIONS

REV OR	ECN No.	DESCRIPTION	DATE	DR	AUTH
	M168691	NEW RELEASE	06/29/18	GF	GH

SUGGESTED MOUNTING CONFIGURATION FOR MC1630-1 CASE STYLE, "06AM06" PIN CODE

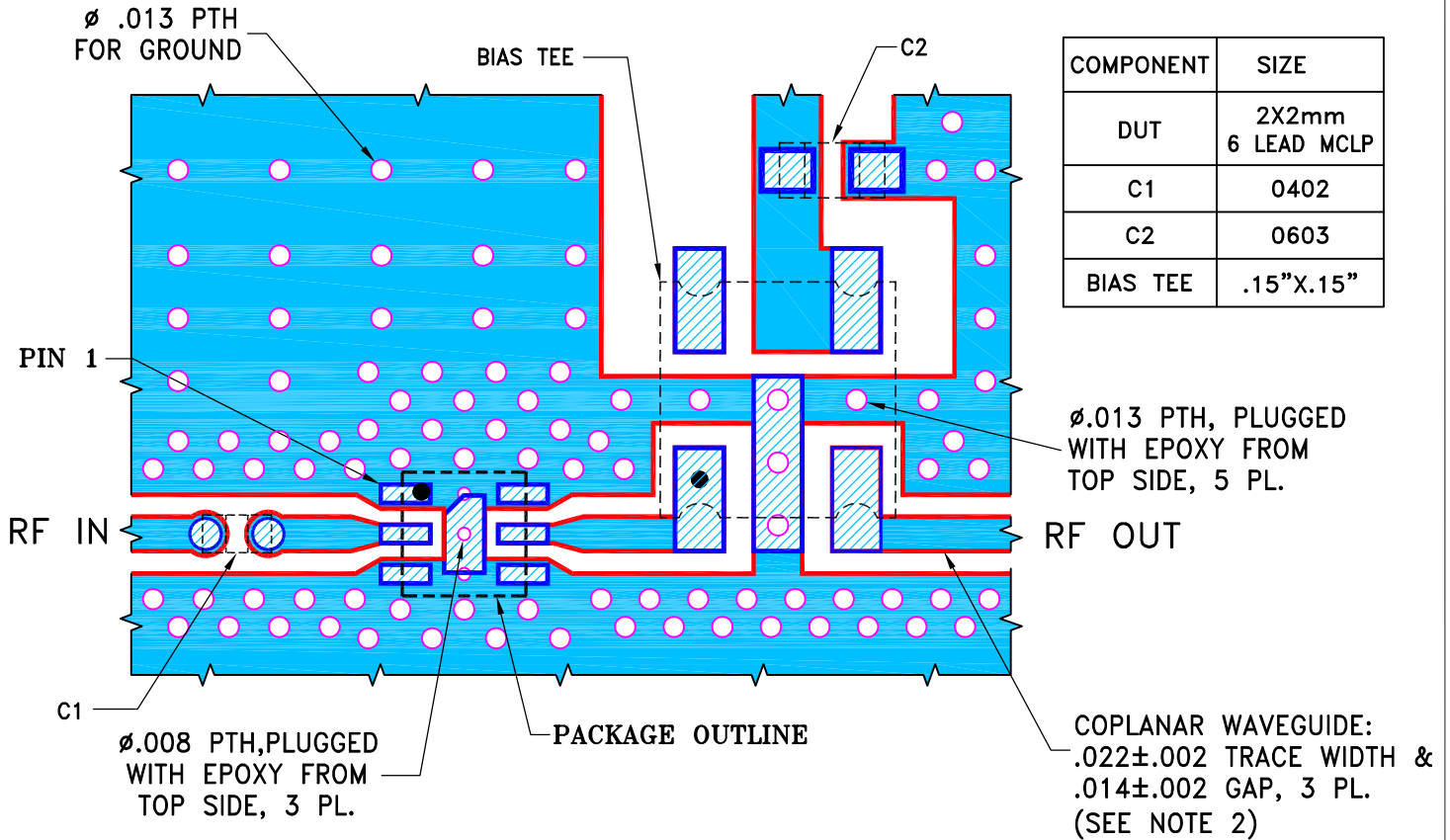

COMPONENT	SIZE
DUT	2X2mm 6 LEAD MCLP
C1	0402
C2	0603
BIAS TEE	.15"X.15"

COPPER LAYER 1

NOTES:

1. PCB IS MULTILAYER PCB, SEE STACK-UP DIAGRAM.
2. TRACE WIDTH & GAP PARAMETERS ARE SHOWN FOR ROGERS RO4350B WITH DIELECTRIC THICKNESS .010"±.001"; COPPER: 1/2 OZ. FOR OTHER MATERIALS TRACE WIDTH AND GAP MAY NEED TO BE MODIFIED.
3. CHIP COMPONENT FOOTPRINTS ARE SHOWN FOR REFERENCE.
4. LAYER 3 OF THE PCB IS CONTINUOUS GROUND PLANE.

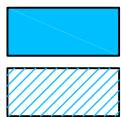

SOLID BLUE DENOTES PCB COPPER LAYOUT WITH SMOBC (SOLDER MASK OVER BARE COPPER)  
 HATCHED BLUE DENOTES COPPER LAND PATTERN FREE OF SOLDER MASK

UNLESS OTHERWISE SPECIFIED	INITIALS		DATE
	DRAWN	GF	06/28/18
	CHECKED	IL	06/28/18
	APPROVED	GH	06/29/18

**Mini-Circuits<sup>®</sup>** 13 Neptune Avenue  
Brooklyn NY 11235

**PL, 06AM06, MC1630-1, TB-1064+**

SIZE	CODE IDENT	DRAWING NO:	REV:
A	15542	98-PL-593	OR
FILE:	98PL593	SCALE: 8:1	SHEET: 1 OF 2

**Mini-Circuits<sup>®</sup>**  
 THIS DOCUMENT AND ITS CONTENTS ARE THE PROPERTY OF MINI-CIRCUITS. EXCEPT FOR USE EXPRESSLY GRANTED, IN WRITING, TO ITS VENDORS, VENDEE AND THE UNITED STATES GOVERNMENT, MINI-CIRCUITS RESERVES ALL PROPRIETARY DESIGN, USE, MANUFACTURING AND REPRODUCTION RIGHTS THERETO. THESE CONTENTS SHALL NOT BE USED, DUPLICATED OR DISCLOSED TO ANY OUTSIDE PARTY, IN WHOLE OR IN PART, WITHOUT WRITTEN PERMISSION OF MINI-CIRCUITS.

SCRATCH IN COPPER  
LAYER 2 UNDER  
BIAS TEE PADS, 4 PL.

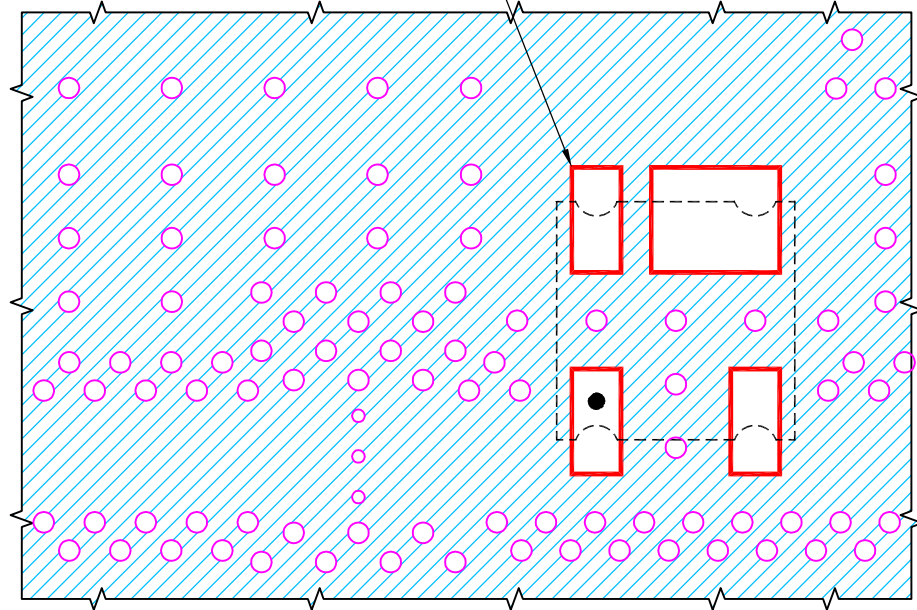

COPPER LAYER 2

STACK-UP DIAGRAM

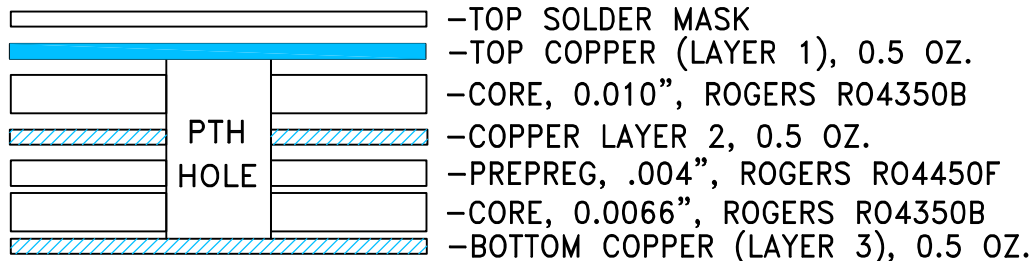

1. TOTAL FINISHED THICKNESS 0.026" ± 10%.
2. PTH HOLES PRESENT FROM COPPER LAYER 1 TO 3.

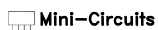

THIS DOCUMENT AND ITS CONTENTS ARE THE PROPERTY OF MINI-CIRCUITS. EXCEPT FOR USE EXPRESSLY GRANTED, IN WRITING, TO ITS VENDORS, VENDEE AND THE UNITED STATES GOVERNMENT, MINI-CIRCUITS RESERVES ALL PROPRIETARY DESIGN, USE, MANUFACTURING AND REPRODUCTION RIGHTS THERETO. THESE CONTENTS SHALL NOT BE USED, DUPLICATED OR DISCLOSED TO ANY OUTSIDE PARTY, IN WHOLE OR IN PART, WITHOUT WRITTEN PERMISSION OF MINI-CIRCUITS.

ALL DIMENSIONS ARE IN INCHES EXCEPT OTHERWISE SPECIFIED

SIZE A	CODE IDENT 15542	DRAWING NO: 98-PL-593	REV: OR
FILE: 98PL593	SCALE: 8:1	SHEET: 2	OF 2

# Evaluation Board and Circuit

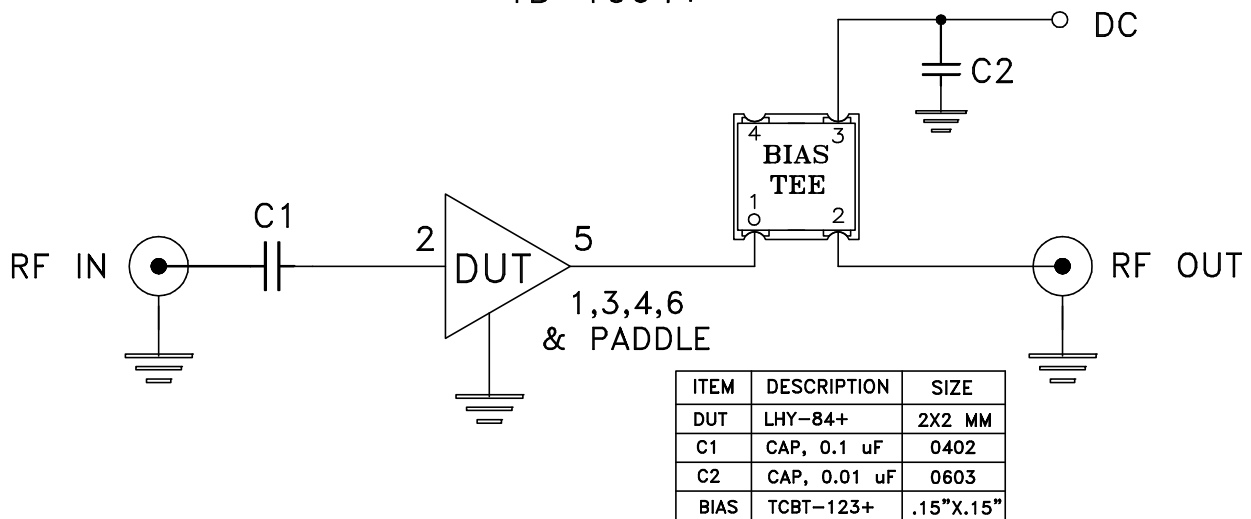
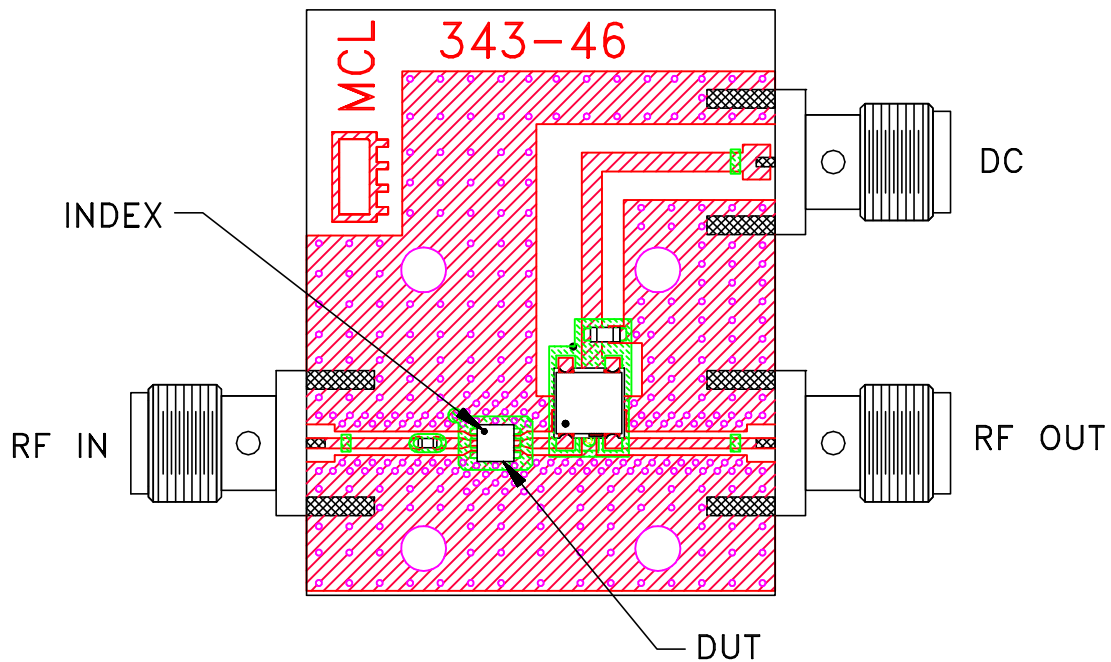

## Schematic Diagram

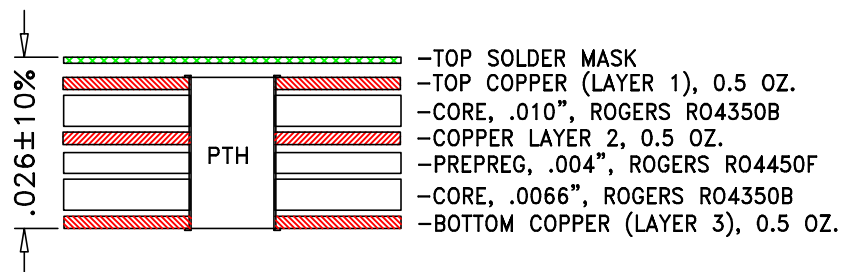

## Notes:

1. 50 Ohm SMA Female connectors.
2. PCB Material: R04350 or equivalent, Dielectric Constant=3.5, Thickness=.032 inch.

 **Mini-Circuits®**

All Mini-Circuits products are manufactured under exacting quality assurance and control standards, and are capable of meeting published specifications after being subjected to any or all of the following physical and environmental test.

Specification	Test/Inspection Condition	Reference/Spec
Operating Temperature	-40° to 85°C Ambient Environment	Individual Model Data Sheet
Storage Temperature	-55° to 100° C or -65° to 150° Ambient Environment	Individual Model Data Sheet
Thermal Shock	-55° to 100°C, 100 cycles	MIL-STD-202, Method 107, Condition A-3, except +100°C
Mechanical Shock	1.5Kg, 0.5 ms, 5 shock pulses, Y1 direction only	MIL-STD-883, Method 2002, Condition B, except Y1 direction only
Vibration (Variable Frequency)	50g peak	MIL-STD-883, Method 2007, Condition B
Autoclave	15 psig, 100% RH, 121°C, 96 hours	JESD22-A102, Condition C
HAST	130°C, 85% RH, 96 hours	JESD22-A110
Solderability	10X Magnification	J-STD-002, Para 4.2.5, Test S, 95% Coverage
Solder Reflow Heat	Sn-Pb Eutetic Process: 240°C peak Pb-Free Process: 260°C peak	J-STD-020, Table 4-1, 4-2 and 5-2; Figure 5-1
Moisture Sensitivity: Level 1	Bake at 125°C for 24 hours Soak at 85°C/85% RH for 168 hours, Reflow 3 cycles at 260°C peak	J-STD-020
Marking Resistance to Solvents	Isopropyl alcohol + mineral spirits at 25°C; terpene defluxer at 25°C; distilled water + proylene glycol monomethyl ether +	MIL-STD-202, Method 215



All Mini-Circuits products are manufactured under exacting quality assurance and control standards, and are capable of meeting published specifications after being subjected to any or all of the following physical and environmental test.

Specification	Test/Inspection Condition	Reference/Spec
	monoethanolamine at 63°C to 70°C	