

Low Noise, Wideband, Low Current

Monolithic Amplifier

PMA2-183LN+

50Ω 4 to 18 GHz



2mm x 2mm

The Big Deal

- Ultra wideband, 4 to 18 GHz
- Excellent noise figure, 2.5 dB at 15GHz
- Low Current, 48mA
- Usable up to 20 GHz

Product Overview

The PMA2-183LN+ is a E-PHEMT based wideband, low noise MMIC amplifier with an unique combination of low noise, high IP3, and low current making it ideal for sensitive, high-dynamic-range receiver applications. This design operates on a single 5V supply, is well matched for 50Ω and comes in a tiny, low profile package (2 x 2 mm, 8 lead MCLP), accommodating dense circuit board layouts.

Key Features

Feature	Advantages
Excellent Noise Figure up to 18 GHz <ul style="list-style-type: none">• 2.7 dB typ. at 4 GHz• 2.5 dB typ. at 18 GHz	Enables lower system noise figure performance.
High IP3 <ul style="list-style-type: none">• +31 dBm at 4 GHz• +29.2 dBm at 20 GHz	Combination of low noise figure and high IP3 makes this MMIC amplifier ideal for use in low noise receiver front end (RFE) as it gives the user advantages of sensitivity and two-tone IM performance at both ends of the dynamic range.
Low operating voltage & current 5V & 48mA	Low voltage & current consumption is ideal for use in amplifier chain.
2 x 2mm 8-lead MCLP package	Tiny footprint saves space in dense layouts while providing low inductance, repeatable transitions, and excellent thermal contact to the PCB.



Low Noise, Wideband, Low Current Monolithic Amplifier

PMA2-183LN+

50Ω 4 to 18 GHz

Product Features

- Ultra wideband, 4 to 18 GHz
- Excellent Noise figure, 2.5 dB typ. at 15 GHz
- Low current, 48mA
- Usable to 20 GHz

Typical Applications

- WiFi
- WLAN
- LTE
- WiMAX
- C-band Satcom



Generic photo used for illustration purposes only

CASE STYLE: MC1631-1

+RoHS Compliant

The +Suffix identifies RoHS Compliance. See our web site for RoHS Compliance methodologies and qualifications

General Description

The PMA2-183LN+ is a E-PHEMT based wideband, low noise MMIC amplifier with an unique combination of low noise, high IP3, and low current making it ideal for sensitive, high-dynamic-range receiver applications. This design operates on a single 5V supply, is well matched for 50Ω and comes in a tiny, low profile package (2 x 2 mm, 8 lead MCLP), accommodating dense circuit board layouts.

simplified schematic & pad description

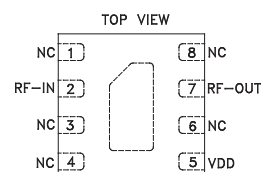
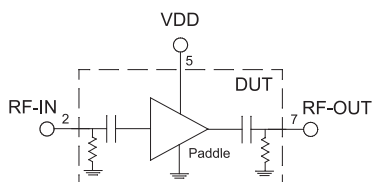

Function	Pad Number	Description (See Figure 1)
RF-IN	2	Connects to RF input
RF-OUT	7	Connects to RF output
Ground	Paddle	Connects to ground
No Connection	1,3,4,6,8	Not used internally. Connected to ground on Test Board.
V _{DD}	5	Connects to voltage supply

Electrical Specifications¹ at 25°C, unless noted

Parameter	Condition (GHz)	V _{DD} =5.0			Units
		Min.	Typ.	Max.	
Frequency Range		4	18		GHz
Gain	4	11.9	13.2	14.5	dB
	10	10.6	11.8	13.0	
	12	9.4	10.4	11.5	
	15	9.8	10.9	12.0	
	18	9.1	10.2	11.2	
	20	--	9.3	--	
Input Return Loss	4		10		dB
	10		11		
	12		11		
	15		15		
	18		12		
	20		11		
Output Return Loss	4		12		dB
	10		15		
	12		15		
	15		20		
	18		13		
	20		11		
Output Power at 1dB Compression	4		16		dBm
	10		14.4		
	12		14.2		
	15		15.8		
	18		14.6		
	20		12.8		
Output IP3	4		31		dBm
	10		26.3		
	12		25.6		
	15		28.1		
	18		27.7		
	20		29.2		
Noise Figure	4		2.7		
	10		2.5		
	12		2.5		
	15		2.5		
	18		2.5		
	20		2.9		
Device Operating Voltage (V _{DD})		4.75	5	5.25	V
Device Operating Current (I _{DD})		—	48.2	58	mA
Device Current Variation vs. Temperature ²			2.31		μA/°C
Device Current Variation vs. Voltage			0.01		mA/mV
Thermal Resistance, junction-to-ground lead			71.9		°C/W

1. Measured on Mini-Circuits Characterization Test Board TB-PMA2-183LN+. See Characterization Test Circuit (Fig. 1)

2. Device Current Variation vs. Temperature= (Current at 85°C - Current at -45°C)/130

3. Device Current Variation vs. Voltage = (Current at 5.25V - Current at 4.75V) / ((5.25V-4.75V)*1000 mV/V)

Absolute Maximum Ratings⁴

Parameter	Ratings
Operating Temperature (ground lead)	-40°C to 85°C
Storage Temperature	-65°C to 150°C
Junction Temperature	141°C
Total Power Dissipation	0.95W
Input Power (CW), V _d =5V	+24 dBm (5 minutes max.) +12 dBm (continuous)
DC Voltage at Pad 5	7V

4. Permanent damage may occur if any of these limits are exceeded.
Electrical maximum ratings are not intended for continuous normal operation.



Characterization Test Circuit

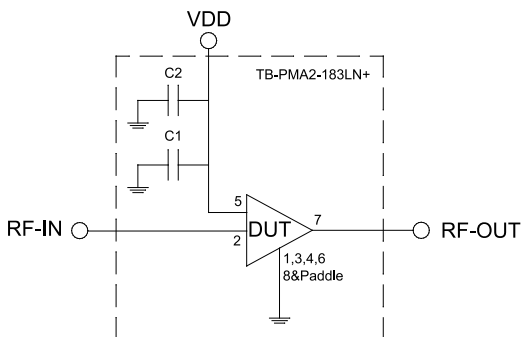

Component	Size	Value	Part Number	Manufacturer
C1	0402	100pF	GRM1555C1H101JA01J	Murata
C2	0402	0.1uF	GRM155R71C104KA88D	Murata

Fig 1. Application and Characterization Circuit

Note: This block diagram is used for characterization. (DUT soldered on Mini-Circuits Characterization test board TB-PMA2-183LN+) Gain, Return loss, Output power at 1dB compression (P1 dB), output IP3 (OIP3) and noise figure measured using Agilent’s N5242A PNA-X microwave network analyzer.

Conditions:

1. Gain and Return loss: Pin= -25dBm
2. Output IP3 (OIP3): Two tones, spaced 1 MHz apart, 0dBm/tone at output.

Product Marking



Marking may contain other features or characters for internal lot control

Additional Detailed Technical Information	
<i>additional information is available on our dash board. To access this information click here</i>	
Performance Data	Data Table
	Swept Graphs
	S-Parameter (S2P Files) Data Set (.zip file)
Case Style	MC1631-1 <i>Plastic package, exposed paddle, lead finish: Matte-Tin</i>
Tape & Reel Standard quantities available on reel	F66 <i>7" reels with 20, 50, 100, 200, 500, 1K or 2K devices</i>
Suggested Layout for PCB Design	PL-636
Evaluation Board	TB-PMA2-183LN+
Environmental Ratings	ENV08T1

ESD Rating

Human Body Model (HBM): Class 1A (250 to <500V) in accordance with ANSI/ESD STM 5.1 - 2001

MSL Test Flow Chart

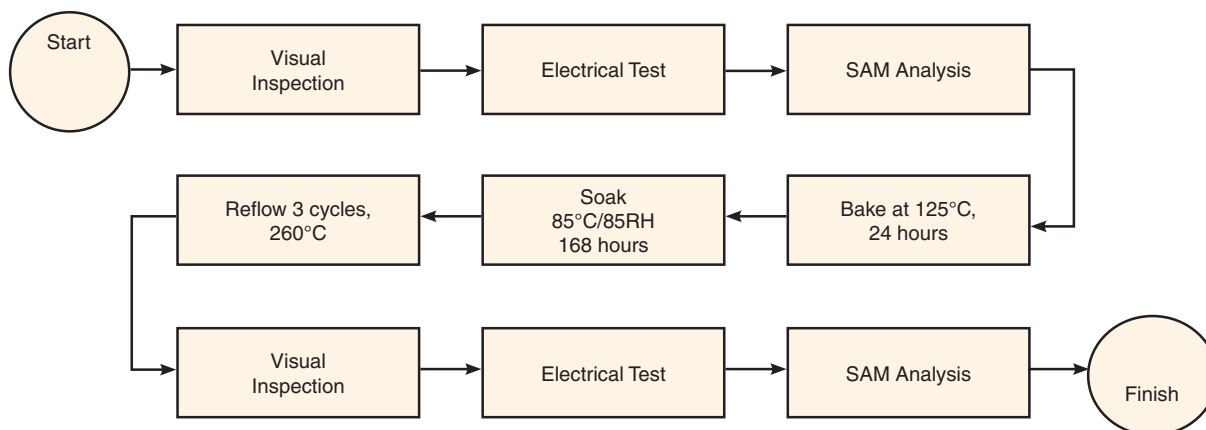

Additional Notes

- A. Performance and quality attributes and conditions not expressly stated in this specification document are intended to be excluded and do not form a part of this specification document.
- B. Electrical specifications and performance data contained in this specification document are based on Mini-Circuit's applicable established test performance criteria and measurement instructions.
- C. The parts covered by this specification document are subject to Mini-Circuits standard limited warranty and terms and conditions (collectively, "Standard Terms"); Purchasers of this part are entitled to the rights and benefits contained therein. For a full statement of the Standard Terms and the exclusive rights and remedies thereunder, please visit Mini-Circuits' website at www.minicircuits.com/MCLStore/terms.jsp

Typical Performance Data

NOTE: Use PDF Bookmarks to view DATA at required conditions

Definitions:

- Input Return Loss = -S11 (dB)
- Gain(Power Gain) = S21 (dB)
- Reverse Isolation = -S12 (dB)
- Output Return Loss = -S22 (dB)

TEST CONDITIONS: Vd = 5.00V, Id = 49mA @ Temperature = +25°C

FREQ	Gain	Isolation	Input Return Loss	Output Return Loss	Stability		IP-3 Output	1dB Comp. Output	Noise Figure
					K	Measure			
(MHz)	(dB)	(dB)	(dB)	(dB)	K	Measure	(dBm)	(dBm)	(dB)
4000	13.10	22.68	9.59	11.35	1.39	0.93	31.10	16.03	2.74
4200	13.24	22.49	10.14	13.07	1.39	0.94	30.81	16.23	2.71
4400	13.32	22.34	10.53	14.81	1.39	0.95	30.55	16.35	2.67
4600	13.36	22.24	10.79	16.42	1.39	0.96	30.11	16.43	2.65
4800	13.38	22.16	10.98	17.83	1.39	0.95	29.92	16.45	2.64
5000	13.39	22.09	11.14	18.85	1.39	0.95	29.62	16.45	2.59
5200	13.38	22.06	11.32	19.59	1.40	0.95	29.46	16.40	2.57
5400	13.37	22.01	11.50	20.00	1.40	0.94	29.08	16.44	2.57
5600	13.35	21.98	11.72	20.20	1.41	0.94	29.24	16.36	2.56
5800	13.31	21.96	11.95	20.25	1.42	0.93	28.94	16.30	2.51
6000	13.27	21.94	12.17	20.30	1.43	0.93	29.34	16.29	2.50
6200	13.23	21.92	12.40	20.25	1.44	0.92	28.32	16.15	2.50
6400	13.17	21.92	12.59	20.23	1.45	0.92	28.72	16.08	2.48
6600	13.11	21.92	12.75	20.19	1.46	0.92	28.55	15.95	2.51
6800	13.05	21.91	12.86	20.07	1.47	0.92	28.44	16.08	2.50
7000	12.98	21.91	12.90	19.98	1.48	0.92	28.58	15.81	2.55
7200	12.91	21.93	12.89	19.80	1.50	0.92	28.85	15.98	2.51
7400	12.84	21.93	12.80	19.60	1.51	0.92	28.76	15.74	2.49
7600	12.76	21.94	12.69	19.32	1.52	0.92	28.86	15.66	2.50
7800	12.69	21.95	12.55	18.98	1.53	0.92	28.98	15.70	2.51
8000	12.62	21.98	12.36	18.60	1.54	0.93	29.06	15.75	2.55
9000	12.23	22.03	11.67	17.01	1.59	0.93	27.48	14.92	2.48
10000	11.79	22.17	11.45	15.55	1.66	0.94	26.60	14.53	2.49
11000	11.06	22.55	10.95	13.80	1.80	0.96	26.46	14.59	2.60
12000	10.42	22.87	10.72	15.11	1.97	1.00	25.99	14.34	2.54
13000	10.73	22.12	11.81	19.40	1.85	0.98	27.40	15.16	2.53
14000	10.95	21.44	13.85	23.11	1.75	0.94	28.15	15.88	2.44
15000	10.87	21.13	14.72	21.56	1.72	0.93	28.67	15.82	2.52
16000	10.65	21.06	13.64	17.37	1.71	0.93	28.73	15.51	2.67
17000	10.42	20.93	12.42	15.01	1.70	0.92	27.97	15.24	2.57
18000	10.21	20.76	12.55	14.68	1.71	0.91	28.71	14.53	2.50
19000	9.93	20.61	12.74	14.57	1.74	0.91	28.92	13.65	2.73
20000	9.31	20.77	10.45	12.17	1.79	0.92	28.20	12.76	3.03

Typical Performance Data

Definitions:

Input Return Loss = -S11 (dB)

Gain(Power Gain) = S21 (dB)

Reverse Isolation = -S12 (dB)

Output Return Loss = -S22 (dB)

TEST CONDITIONS: Vd = 4.75V, Id = 47mA @ Temperature = +25°C

FREQ	Gain	Isolation	Input Return Loss	Output Return Loss	Stability		IP-3 Output	1dB Comp. Output	Noise Figure
					K	Measure			
(MHz)	(dB)	(dB)	(dB)	(dB)	K	Measure	(dBm)	(dBm)	(dB)
4000	13.01	22.64	9.50	11.38	1.40	0.93	30.32	15.44	2.73
4200	13.14	22.45	10.04	13.09	1.39	0.95	30.26	15.56	2.70
4400	13.22	22.32	10.41	14.81	1.39	0.96	29.83	15.68	2.69
4600	13.27	22.23	10.67	16.39	1.39	0.96	29.43	15.76	2.64
4800	13.29	22.17	10.86	17.76	1.40	0.96	29.25	15.87	2.64
5000	13.30	22.09	11.02	18.75	1.40	0.96	29.06	15.78	2.57
5200	13.29	22.05	11.20	19.44	1.41	0.95	28.73	15.82	2.57
5400	13.28	22.00	11.37	19.80	1.41	0.95	28.52	15.77	2.55
5600	13.25	21.97	11.58	20.00	1.42	0.94	28.76	15.78	2.53
5800	13.22	21.95	11.82	20.06	1.43	0.93	28.37	15.63	2.51
6000	13.18	21.91	12.05	20.09	1.44	0.93	28.73	15.63	2.48
6200	13.13	21.91	12.28	20.01	1.45	0.93	27.69	15.49	2.52
6400	13.08	21.89	12.46	19.96	1.46	0.92	28.02	15.41	2.51
6600	13.02	21.90	12.62	19.92	1.47	0.92	27.95	15.28	2.49
6800	12.96	21.89	12.73	19.81	1.48	0.92	27.70	15.31	2.49
7000	12.89	21.89	12.78	19.73	1.49	0.92	28.00	15.15	2.50
7200	12.82	21.91	12.77	19.56	1.50	0.92	28.15	15.31	2.50
7400	12.74	21.91	12.69	19.36	1.51	0.92	28.24	15.08	2.49
7600	12.67	21.93	12.58	19.10	1.53	0.93	28.18	15.10	2.51
7800	12.60	21.95	12.44	18.78	1.54	0.93	28.34	15.14	2.52
8000	12.52	21.96	12.27	18.44	1.55	0.93	28.29	15.09	2.53
9000	12.14	22.04	11.61	16.93	1.60	0.94	26.82	14.37	2.48
10000	11.69	22.13	11.40	15.48	1.67	0.94	26.05	13.86	2.47
11000	10.96	22.54	10.92	13.75	1.82	0.96	25.74	13.92	2.67
12000	10.34	22.81	10.71	15.09	1.98	1.00	25.37	13.82	2.50
13000	10.65	22.08	11.82	19.32	1.86	0.98	26.86	14.64	2.51
14000	10.87	21.41	13.85	23.01	1.76	0.95	27.67	15.35	2.43
15000	10.78	21.15	14.72	21.35	1.73	0.94	28.19	15.29	2.51
16000	10.56	21.00	13.67	17.33	1.71	0.93	28.09	15.10	2.70
17000	10.33	20.90	12.48	15.05	1.71	0.93	27.56	14.83	2.61
18000	10.12	20.70	12.62	14.77	1.72	0.92	28.38	14.11	2.50
19000	9.85	20.58	12.82	14.70	1.75	0.92	28.39	13.25	2.70
20000	9.23	20.70	10.53	12.31	1.79	0.92	27.86	12.38	2.99

Typical Performance Data

Definitions:

Input Return Loss = -S11 (dB)

Gain(Power Gain) = S21 (dB)

Reverse Isolation = -S12 (dB)

Output Return Loss = -S22 (dB)

TEST CONDITIONS: Vd = 5.25, Id = 52mA @ Temperature = +25°C

FREQ	Gain	Isolation	Input Return Loss	Output Return Loss	Stability		IP-3 Output	1dB Comp. Output	Noise Figure
					K	Measure			
(MHz)	(dB)	(dB)	(dB)	(dB)	K	Measure	(dBm)	(dBm)	(dB)
4000	13.18	22.65	9.66	11.34	1.38	0.92	31.60	16.73	2.79
4200	13.32	22.47	10.24	13.08	1.38	0.94	31.52	16.85	2.72
4400	13.40	22.34	10.63	14.84	1.38	0.95	31.18	16.98	2.73
4600	13.44	22.24	10.90	16.48	1.38	0.95	30.70	16.98	2.69
4800	13.47	22.17	11.10	17.93	1.39	0.95	30.43	17.08	2.70
5000	13.47	22.11	11.25	18.99	1.39	0.95	30.07	17.08	2.62
5200	13.47	22.08	11.43	19.76	1.40	0.94	30.02	17.03	2.59
5400	13.45	22.03	11.61	20.19	1.40	0.94	29.71	17.07	2.57
5600	13.43	21.98	11.82	20.42	1.41	0.93	29.74	16.99	2.56
5800	13.40	21.97	12.06	20.48	1.42	0.93	29.59	16.84	2.56
6000	13.35	21.96	12.28	20.52	1.43	0.92	29.94	16.83	2.53
6200	13.31	21.92	12.51	20.47	1.43	0.92	28.98	16.68	2.53
6400	13.25	21.92	12.69	20.44	1.44	0.92	29.33	16.60	2.52
6600	13.20	21.92	12.85	20.41	1.46	0.92	29.10	16.47	2.53
6800	13.13	21.92	12.96	20.29	1.47	0.91	28.86	16.50	2.54
7000	13.07	21.94	13.00	20.18	1.48	0.92	29.19	16.22	2.54
7200	12.99	21.93	12.98	19.99	1.49	0.92	29.25	16.50	2.54
7400	12.92	21.95	12.89	19.77	1.50	0.92	29.43	16.26	2.54
7600	12.85	21.96	12.78	19.49	1.51	0.92	29.44	16.29	2.53
7800	12.77	21.99	12.62	19.13	1.52	0.92	29.65	16.33	2.56
8000	12.70	22.00	12.44	18.73	1.53	0.92	29.49	16.38	2.58
9000	12.32	22.08	11.72	17.07	1.59	0.93	28.16	15.43	2.51
10000	11.87	22.18	11.47	15.60	1.65	0.94	27.22	15.15	2.55
11000	11.14	22.61	10.96	13.83	1.80	0.95	27.05	15.09	2.64
12000	10.48	22.89	10.70	15.11	1.96	1.00	26.42	14.72	2.53
13000	10.79	22.20	11.80	19.44	1.86	0.98	27.93	15.65	2.54
14000	11.03	21.48	13.83	23.11	1.74	0.94	28.73	16.38	2.44
15000	10.95	21.20	14.69	21.66	1.71	0.93	29.16	16.30	2.54
16000	10.73	21.10	13.59	17.40	1.70	0.93	29.58	15.98	2.70
17000	10.49	20.99	12.36	14.94	1.70	0.92	28.78	15.70	2.59
18000	10.28	20.81	12.47	14.56	1.71	0.91	29.12	14.98	2.52
19000	10.00	20.67	12.64	14.43	1.73	0.91	29.52	14.09	2.76
20000	9.37	20.83	10.38	12.04	1.79	0.92	29.05	13.10	3.02

Typical Performance Data

Definitions:

Input Return Loss = -S11 (dB)

Gain(Power Gain) = S21 (dB)

Reverse Isolation = -S12 (dB)

Output Return Loss = -S22 (dB)

TEST CONDITIONS: Vd = 5.00V, Id = 50mA @ Temperature = -45°C

FREQ	Gain	Isolation	Input Return Loss	Output Return Loss	Stability		IP-3 Output	1dB Comp. Output	Noise Figure
					K	Measure			
(MHz)	(dB)	(dB)	(dB)	(dB)	K	Measure	(dBm)	(dBm)	(dB)
4000	13.35	22.88	10.03	10.90	1.40	0.90	31.68	16.23	2.22
4200	13.50	22.69	10.71	12.59	1.40	0.92	31.45	16.36	2.23
4400	13.59	22.53	11.20	14.30	1.40	0.93	31.07	16.48	2.15
4600	13.65	22.43	11.54	15.96	1.40	0.93	30.77	16.55	2.13
4800	13.67	22.35	11.79	17.44	1.40	0.93	30.37	16.58	2.09
5000	13.68	22.29	12.01	18.73	1.40	0.93	30.21	16.58	2.04
5200	13.67	22.24	12.21	19.72	1.41	0.93	29.87	16.51	2.06
5400	13.65	22.20	12.43	20.42	1.42	0.92	29.78	16.56	2.05
5600	13.62	22.18	12.66	20.91	1.42	0.92	29.63	16.46	2.05
5800	13.58	22.15	12.88	21.23	1.43	0.92	29.47	16.31	2.02
6000	13.54	22.13	13.12	21.40	1.44	0.91	29.72	16.30	2.03
6200	13.49	22.12	13.35	21.41	1.45	0.91	28.77	16.02	2.00
6400	13.43	22.13	13.52	21.36	1.46	0.91	29.17	15.93	1.99
6600	13.38	22.11	13.63	21.24	1.47	0.91	29.08	15.81	2.02
6800	13.32	22.09	13.73	21.15	1.48	0.91	28.71	15.83	2.01
7000	13.26	22.10	13.76	21.12	1.49	0.91	29.05	15.53	2.01
7200	13.19	22.11	13.71	20.97	1.50	0.91	29.21	15.84	1.97
7400	13.14	22.10	13.57	20.71	1.50	0.91	29.19	15.49	1.97
7600	13.08	22.08	13.40	20.42	1.51	0.91	29.17	15.54	2.02
7800	13.02	22.07	13.18	20.08	1.51	0.92	29.54	15.48	1.97
8000	12.95	22.09	12.98	19.79	1.52	0.92	29.44	15.56	1.93
9000	12.58	22.16	12.03	17.94	1.57	0.93	27.87	14.67	1.93
10000	12.16	22.21	11.81	16.28	1.63	0.93	26.95	14.19	1.90
11000	11.48	22.52	11.78	14.57	1.76	0.94	27.01	14.46	1.94
12000	10.80	22.88	11.69	15.45	1.93	0.98	26.27	14.31	1.91
13000	11.01	22.29	12.54	19.70	1.84	0.97	27.62	15.30	1.84
14000	11.29	21.51	14.08	23.72	1.71	0.94	28.70	16.00	1.71
15000	11.27	21.20	14.70	21.67	1.66	0.93	29.52	16.09	1.94
16000	11.09	21.05	13.95	17.68	1.64	0.92	29.90	15.88	1.94
17000	10.91	20.90	13.05	15.59	1.63	0.91	28.92	15.75	1.88
18000	10.73	20.71	13.60	15.47	1.64	0.90	29.02	15.00	1.77
19000	10.49	20.57	14.23	15.36	1.67	0.90	30.22	14.19	2.00
20000	9.90	20.73	11.40	12.48	1.71	0.91	29.62	13.33	2.26

Typical Performance Data

Definitions:

Input Return Loss = -S11 (dB)

Gain(Power Gain) = S21 (dB)

Reverse Isolation = -S12 (dB)

Output Return Loss = -S22 (dB)

TEST CONDITIONS: Vd = 4.75, Id = 46mA @ Temperature = -45°C

FREQ	Gain	Isolation	Input Return Loss	Output Return Loss	Stability		IP-3 Output	1dB Comp. Output	Noise Figure
					K	Measure			
(MHz)	(dB)	(dB)	(dB)	(dB)	K	Measure	(dBm)	(dBm)	(dB)
4000	13.25	22.87	9.97	10.95	1.41	0.91	30.71	15.56	2.20
4200	13.40	22.67	10.62	12.64	1.41	0.92	30.77	15.68	2.17
4400	13.49	22.53	11.09	14.35	1.40	0.93	30.27	15.80	2.14
4600	13.55	22.43	11.42	16.00	1.41	0.94	29.79	15.87	2.12
4800	13.57	22.34	11.66	17.46	1.41	0.94	29.52	15.89	2.08
5000	13.58	22.27	11.88	18.71	1.41	0.94	29.22	15.89	2.03
5200	13.57	22.23	12.08	19.66	1.42	0.93	29.02	15.83	2.01
5400	13.55	22.19	12.29	20.30	1.42	0.93	28.86	15.87	2.04
5600	13.51	22.15	12.53	20.75	1.43	0.93	28.89	15.78	2.01
5800	13.48	22.13	12.75	21.02	1.44	0.92	28.65	15.71	2.00
6000	13.44	22.12	12.99	21.19	1.45	0.92	28.97	15.61	1.94
6200	13.39	22.12	13.20	21.17	1.46	0.92	27.97	15.33	1.98
6400	13.33	22.11	13.37	21.10	1.47	0.92	28.12	15.23	1.96
6600	13.28	22.10	13.49	20.98	1.48	0.91	28.06	15.12	1.96
6800	13.22	22.07	13.58	20.89	1.48	0.91	27.71	15.14	1.96
7000	13.15	22.07	13.62	20.83	1.49	0.91	28.18	14.95	2.00
7200	13.09	22.10	13.57	20.68	1.51	0.91	28.38	15.15	1.95
7400	13.04	22.07	13.43	20.45	1.51	0.92	28.33	14.92	1.93
7600	12.98	22.07	13.27	20.15	1.51	0.92	28.35	14.85	1.96
7800	12.92	22.07	13.06	19.84	1.52	0.92	28.39	14.90	1.94
8000	12.85	22.05	12.86	19.55	1.53	0.92	28.50	14.86	1.95
9000	12.48	22.12	11.94	17.79	1.57	0.93	26.87	13.97	1.89
10000	12.06	22.18	11.75	16.21	1.64	0.93	26.06	13.62	1.88
11000	11.38	22.50	11.75	14.51	1.77	0.94	26.19	13.89	1.94
12000	10.71	22.85	11.69	15.42	1.95	0.98	25.55	13.64	1.81
13000	10.93	22.25	12.53	19.61	1.85	0.97	26.87	14.66	1.82
14000	11.20	21.46	14.07	23.52	1.71	0.94	28.02	15.45	1.69
15000	11.18	21.18	14.71	21.49	1.67	0.93	28.46	15.55	1.95
16000	10.99	21.04	13.94	17.61	1.66	0.92	28.81	15.45	1.94
17000	10.81	20.88	13.08	15.60	1.64	0.91	28.44	15.24	1.84
18000	10.64	20.67	13.64	15.52	1.65	0.90	28.65	14.56	1.75
19000	10.40	20.53	14.30	15.44	1.67	0.90	29.61	13.77	1.96
20000	9.81	20.67	11.48	12.58	1.71	0.91	29.13	12.94	2.27

Typical Performance Data

Definitions:

Input Return Loss = -S11 (dB)

Gain(Power Gain) = S21 (dB)

Reverse Isolation = -S12 (dB)

Output Return Loss = -S22 (dB)

TEST CONDITIONS: Vd = 5.25V, Id = 53mA @ Temperature = -45°C

FREQ	Gain	Isolation	Input Return Loss	Output Return Loss	Stability		IP-3 Output	1dB Comp. Output	Noise Figure
					K	Measure			
(MHz)	(dB)	(dB)	(dB)	(dB)	K	Measure	(dBm)	(dBm)	(dB)
4000	13.44	22.88	10.09	10.88	1.39	0.90	32.37	16.86	2.26
4200	13.58	22.69	10.79	12.58	1.39	0.91	31.91	16.99	2.23
4400	13.68	22.54	11.30	14.30	1.39	0.92	32.15	17.12	2.18
4600	13.73	22.43	11.64	15.98	1.39	0.93	31.42	17.19	2.15
4800	13.76	22.35	11.90	17.48	1.39	0.93	31.26	17.22	2.14
5000	13.76	22.29	12.13	18.79	1.40	0.93	31.21	17.22	2.11
5200	13.75	22.25	12.33	19.81	1.40	0.92	30.59	17.16	2.08
5400	13.73	22.21	12.54	20.55	1.41	0.92	30.63	17.21	2.09
5600	13.70	22.18	12.77	21.08	1.42	0.92	30.58	17.11	2.07
5800	13.66	22.16	13.00	21.42	1.42	0.91	30.27	17.05	2.03
6000	13.62	22.15	13.24	21.61	1.43	0.91	30.49	16.95	2.01
6200	13.57	22.14	13.46	21.62	1.44	0.91	29.60	16.68	2.02
6400	13.52	22.12	13.64	21.58	1.45	0.91	29.92	16.69	2.02
6600	13.46	22.12	13.75	21.46	1.46	0.91	29.82	16.58	1.99
6800	13.41	22.10	13.84	21.39	1.47	0.91	29.49	16.60	2.02
7000	13.34	22.12	13.88	21.35	1.48	0.91	29.70	16.30	2.01
7200	13.28	22.11	13.82	21.20	1.49	0.91	30.08	16.49	1.97
7400	13.22	22.11	13.67	20.95	1.50	0.91	29.92	16.26	2.01
7600	13.16	22.11	13.50	20.63	1.50	0.91	29.98	16.31	1.96
7800	13.10	22.09	13.28	20.26	1.51	0.91	30.11	16.36	2.00
8000	13.03	22.08	13.07	19.95	1.51	0.91	30.18	16.43	1.98
9000	12.67	22.16	12.10	17.99	1.56	0.92	28.66	15.44	1.96
10000	12.24	22.20	11.85	16.31	1.61	0.93	27.96	14.96	1.89
11000	11.57	22.53	11.81	14.61	1.75	0.94	27.96	15.23	1.99
12000	10.88	22.92	11.69	15.49	1.93	0.98	27.10	14.81	1.93
13000	11.08	22.31	12.52	19.80	1.83	0.97	28.44	15.81	1.89
14000	11.36	21.53	14.08	23.89	1.70	0.94	29.53	16.61	1.69
15000	11.35	21.25	14.70	21.82	1.66	0.93	30.39	16.59	1.95
16000	11.17	21.08	13.92	17.69	1.64	0.92	30.44	16.45	2.00
17000	10.98	20.94	13.00	15.54	1.63	0.91	29.82	16.21	1.86
18000	10.81	20.74	13.53	15.39	1.64	0.90	30.04	15.51	1.81
19000	10.57	20.58	14.16	15.24	1.66	0.89	31.14	14.63	2.03
20000	9.96	20.74	11.32	12.36	1.70	0.90	30.20	13.67	2.32

Typical Performance Data

Definitions:

Input Return Loss = -S11 (dB)

Gain(Power Gain) = S21 (dB)

Reverse Isolation = -S12 (dB)

Output Return Loss = -S22 (dB)

TEST CONDITIONS: Vd = 5.00V, Id = 50mA @ Temperature = +85°C

FREQ	Gain	Isolation	Input Return Loss	Output Return Loss	Stability		IP-3 Output	1dB Comp. Output	Noise Figure
					K	Measure			
(MHz)	(dB)	(dB)	(dB)	(dB)	K	Measure	(dBm)	(dBm)	(dB)
4000	12.81	22.51	9.37	11.80	1.40	0.95	30.24	15.86	3.17
4200	12.93	22.33	9.85	13.61	1.40	0.97	30.07	15.96	3.16
4400	13.00	22.21	10.18	15.38	1.40	0.97	29.77	16.16	3.16
4600	13.04	22.13	10.39	16.99	1.40	0.97	29.38	16.24	3.04
4800	13.06	22.05	10.56	18.22	1.41	0.97	29.41	16.26	3.06
5000	13.06	22.00	10.72	19.10	1.41	0.97	28.94	16.26	3.02
5200	13.06	21.95	10.87	19.58	1.42	0.96	28.88	16.21	3.01
5400	13.04	21.91	11.05	19.75	1.42	0.95	28.46	16.24	2.99
5600	13.01	21.89	11.27	19.79	1.44	0.95	28.71	16.16	2.97
5800	12.97	21.88	11.48	19.82	1.45	0.94	28.48	16.01	2.94
6000	12.93	21.86	11.71	19.75	1.46	0.94	28.80	16.01	2.94
6200	12.88	21.86	11.92	19.63	1.47	0.93	27.91	15.87	2.92
6400	12.83	21.85	12.10	19.49	1.48	0.93	28.28	15.90	2.93
6600	12.77	21.82	12.22	19.32	1.49	0.93	28.08	15.67	2.96
6800	12.71	21.83	12.34	19.17	1.50	0.93	27.83	15.80	2.94
7000	12.63	21.86	12.40	19.02	1.52	0.93	28.28	15.54	2.93
7200	12.56	21.88	12.37	18.78	1.53	0.93	28.32	15.70	2.92
7400	12.49	21.89	12.25	18.48	1.54	0.93	28.36	15.58	2.93
7600	12.42	21.92	12.13	18.14	1.55	0.93	28.21	15.49	2.93
7800	12.35	21.90	11.98	17.81	1.56	0.93	28.45	15.43	2.97
8000	12.28	21.91	11.86	17.56	1.57	0.93	28.40	15.49	2.98
9000	11.90	22.04	11.35	16.46	1.63	0.94	27.09	14.89	2.92
10000	11.44	22.17	11.18	15.15	1.71	0.95	26.13	14.50	2.91
11000	10.66	22.58	10.55	13.34	1.86	0.96	26.06	14.39	3.03
12000	10.09	22.84	10.37	14.85	2.02	1.00	25.62	14.09	2.96
13000	10.41	22.12	11.34	18.30	1.90	0.99	26.98	14.91	2.89
14000	10.59	21.50	12.83	20.90	1.80	0.96	27.54	15.57	2.82
15000	10.52	21.22	13.87	20.63	1.78	0.94	28.21	15.48	3.13
16000	10.28	21.13	13.36	17.16	1.78	0.94	28.21	15.19	3.12
17000	10.02	21.02	12.17	14.62	1.77	0.93	27.55	14.80	3.00
18000	9.76	20.90	12.02	13.95	1.79	0.92	28.30	14.15	2.90
19000	9.42	20.81	11.86	13.50	1.83	0.92	27.91	13.23	3.24
20000	8.69	21.01	9.65	11.17	1.89	0.93	27.25	12.25	3.54

Typical Performance Data

Definitions:

Input Return Loss = -S11 (dB)

Gain(Power Gain) = S21 (dB)

Reverse Isolation = -S12 (dB)

Output Return Loss = -S22 (dB)

TEST CONDITIONS: Vd = 4.75V, Id = 47mA @ Temperature = +85°C

FREQ	Gain	Isolation	Input Return Loss	Output Return Loss	Stability		IP-3 Output	1dB Comp. Output	Noise Figure
					K	Measure			
(MHz)	(dB)	(dB)	(dB)	(dB)	K	Measure	(dBm)	(dBm)	(dB)
4000	12.72	22.50	9.28	11.80	1.41	0.96	29.61	15.20	3.16
4200	12.84	22.31	9.76	13.61	1.40	0.97	29.48	15.38	3.15
4400	12.92	22.19	10.07	15.35	1.40	0.98	29.52	15.50	3.14
4600	12.96	22.10	10.29	16.92	1.41	0.98	28.86	15.58	3.05
4800	12.97	22.03	10.45	18.12	1.41	0.98	28.71	15.61	3.05
5000	12.98	21.98	10.61	18.95	1.42	0.97	28.49	15.60	3.03
5200	12.97	21.95	10.77	19.40	1.42	0.96	28.45	15.56	2.98
5400	12.95	21.90	10.94	19.56	1.43	0.96	28.04	15.59	2.99
5600	12.92	21.87	11.16	19.59	1.44	0.95	28.30	15.51	2.96
5800	12.89	21.86	11.37	19.59	1.45	0.95	27.96	15.46	2.93
6000	12.85	21.84	11.60	19.54	1.46	0.94	28.25	15.45	2.92
6200	12.80	21.83	11.82	19.45	1.47	0.94	27.42	15.32	2.95
6400	12.74	21.84	12.00	19.29	1.49	0.93	27.68	15.25	2.91
6600	12.69	21.82	12.12	19.12	1.49	0.93	27.60	15.12	2.93
6800	12.62	21.83	12.24	18.98	1.51	0.93	27.34	15.26	2.94
7000	12.54	21.84	12.30	18.83	1.52	0.93	27.76	15.00	2.90
7200	12.47	21.86	12.28	18.61	1.54	0.93	27.84	15.15	2.93
7400	12.40	21.87	12.17	18.32	1.55	0.93	27.94	14.93	2.90
7600	12.33	21.88	12.05	18.01	1.55	0.93	27.78	14.95	2.93
7800	12.26	21.91	11.89	17.68	1.56	0.93	28.01	14.89	2.93
8000	12.19	21.89	11.78	17.44	1.57	0.93	28.10	14.94	2.96
9000	11.81	22.00	11.30	16.41	1.63	0.94	26.65	14.24	2.92
10000	11.35	22.12	11.14	15.12	1.71	0.95	25.69	13.97	2.94
11000	10.57	22.59	10.53	13.31	1.87	0.97	25.54	13.86	3.04
12000	10.01	22.83	10.37	14.84	2.03	1.01	25.16	13.58	2.96
13000	10.34	22.06	11.34	18.27	1.90	0.99	26.58	14.40	2.93
14000	10.51	21.46	12.82	20.92	1.81	0.96	27.25	15.06	2.81
15000	10.43	21.19	13.88	20.65	1.79	0.95	27.65	14.98	3.04
16000	10.20	21.07	13.39	17.16	1.78	0.94	27.91	14.79	3.20
17000	9.94	20.99	12.22	14.67	1.78	0.93	27.22	14.49	3.00
18000	9.68	20.84	12.09	14.03	1.80	0.93	27.70	13.74	2.96
19000	9.35	20.75	11.93	13.64	1.84	0.93	27.69	12.84	3.22
20000	8.63	20.91	9.70	11.30	1.89	0.93	26.84	11.80	3.58

Typical Performance Data

Definitions:

Input Return Loss = -S11 (dB)

Gain(Power Gain) = S21 (dB)

Reverse Isolation = -S12 (dB)

Output Return Loss = -S22 (dB)

TEST CONDITIONS: Vd = 5.25V, Id = 53mA @ Temperature = +85°C

FREQ	Gain	Isolation	Input Return Loss	Output Return Loss	Stability		IP-3 Output	1dB Comp. Output	Noise Figure
					K	Measure			
(MHz)	(dB)	(dB)	(dB)	(dB)	K	Measure	(dBm)	(dBm)	(dB)
4000	12.88	22.51	9.44	11.81	1.40	0.95	30.45	16.39	3.20
4200	13.00	22.32	9.94	13.65	1.39	0.96	30.52	16.58	3.19
4400	13.08	22.19	10.27	15.45	1.39	0.97	30.15	16.69	3.12
4600	13.12	22.11	10.49	17.09	1.40	0.97	29.87	16.77	3.12
4800	13.14	22.05	10.65	18.36	1.40	0.97	29.73	16.79	3.05
5000	13.14	22.00	10.80	19.27	1.41	0.96	29.31	16.78	3.05
5200	13.13	21.96	10.96	19.76	1.41	0.96	29.34	16.74	3.02
5400	13.11	21.92	11.14	19.94	1.42	0.95	28.87	16.77	2.99
5600	13.08	21.91	11.36	20.00	1.43	0.94	29.04	16.77	3.00
5800	13.05	21.88	11.56	20.00	1.44	0.94	28.87	16.62	3.01
6000	13.01	21.85	11.79	19.94	1.45	0.93	29.19	16.52	2.94
6200	12.96	21.86	12.01	19.81	1.46	0.93	28.29	16.38	2.94
6400	12.90	21.84	12.18	19.66	1.47	0.93	28.56	16.40	2.94
6600	12.85	21.82	12.31	19.48	1.48	0.92	28.37	16.28	2.96
6800	12.78	21.84	12.41	19.32	1.49	0.92	28.23	16.31	2.95
7000	12.70	21.86	12.48	19.16	1.51	0.92	28.64	16.04	2.92
7200	12.63	21.90	12.44	18.90	1.53	0.93	28.76	16.20	2.94
7400	12.56	21.92	12.32	18.58	1.53	0.93	28.76	15.97	2.93
7600	12.50	21.92	12.20	18.23	1.54	0.93	28.74	16.00	2.95
7800	12.43	21.93	12.04	17.90	1.55	0.93	29.03	16.04	2.96
8000	12.35	21.92	11.90	17.63	1.56	0.93	28.93	16.10	2.93
9000	11.98	22.02	11.39	16.49	1.62	0.94	27.46	15.27	2.90
10000	11.52	22.17	11.19	15.18	1.70	0.94	26.56	14.87	2.93
11000	10.74	22.62	10.55	13.35	1.85	0.96	26.46	14.77	3.07
12000	10.15	22.92	10.34	14.84	2.02	1.00	26.05	14.56	3.00
13000	10.47	22.17	11.32	18.29	1.90	0.99	27.40	15.38	2.93
14000	10.66	21.53	12.79	20.78	1.80	0.96	28.01	15.95	2.81
15000	10.59	21.23	13.82	20.62	1.77	0.94	28.49	15.85	3.02
16000	10.36	21.14	13.29	17.11	1.77	0.94	28.70	15.45	3.11
17000	10.09	21.06	12.11	14.53	1.77	0.93	27.99	15.24	3.10
18000	9.83	20.93	11.95	13.82	1.79	0.92	28.57	14.59	3.00
19000	9.48	20.86	11.77	13.35	1.83	0.92	28.65	13.59	3.24
20000	8.74	21.04	9.58	11.03	1.89	0.93	27.69	12.59	3.57

Typical Performance Curves

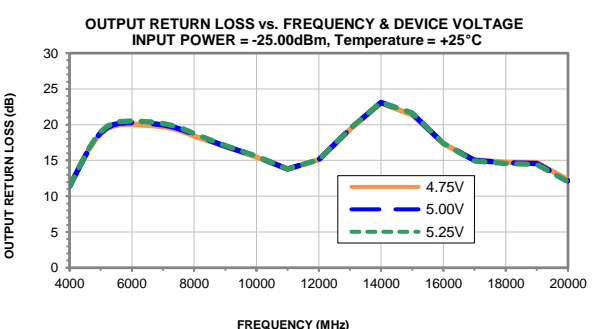
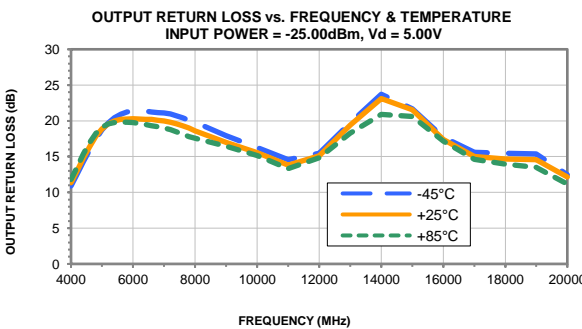
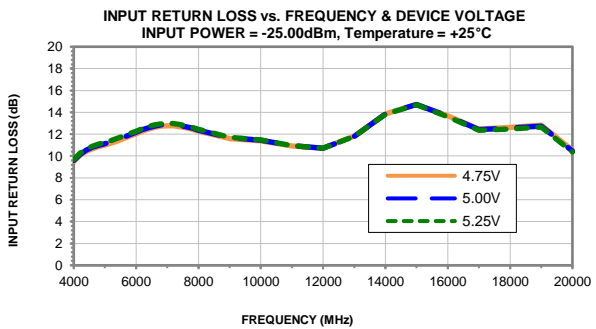
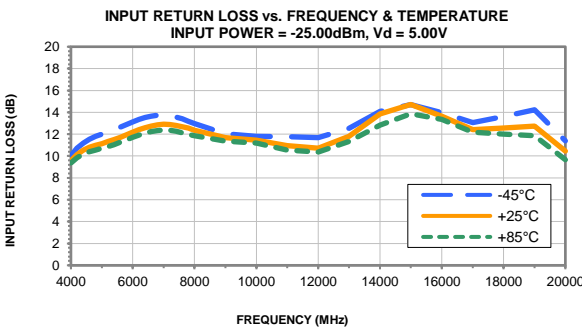
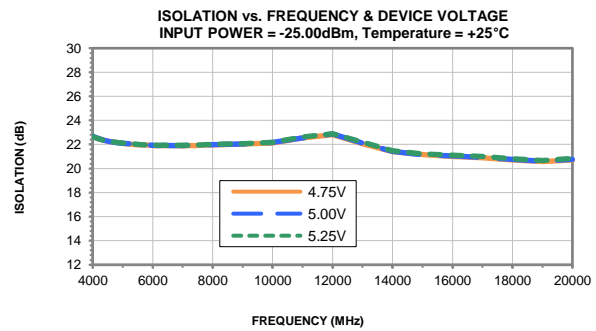
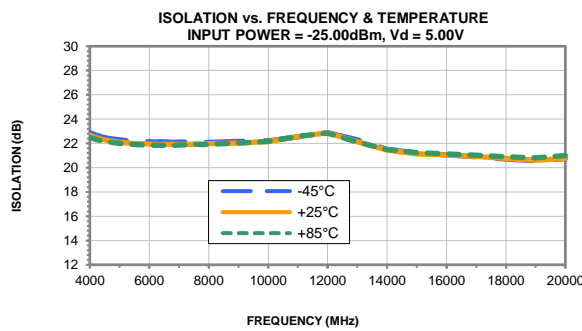
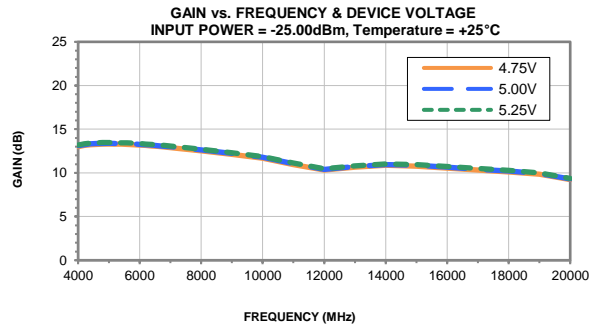
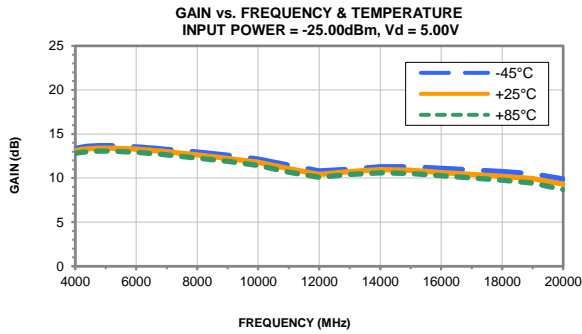

Typical Performance Curves

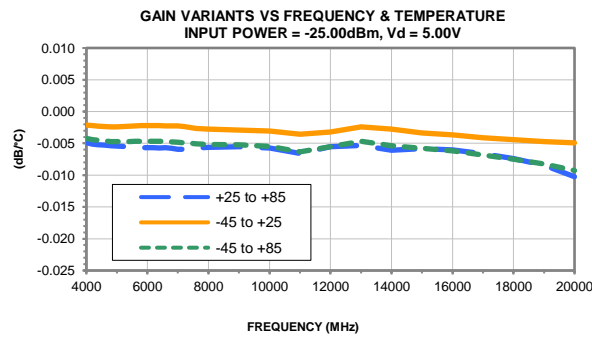
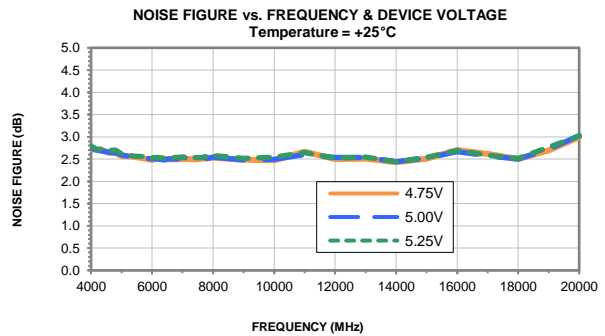
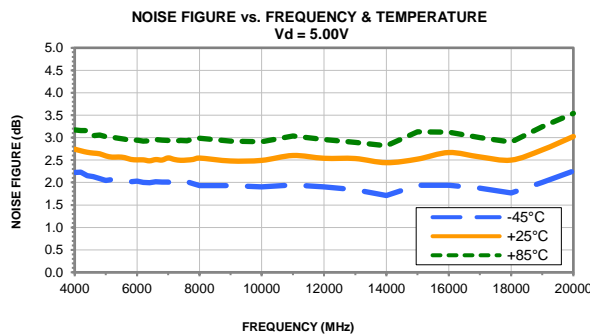
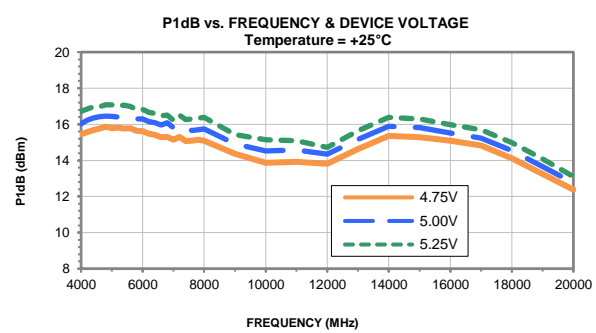
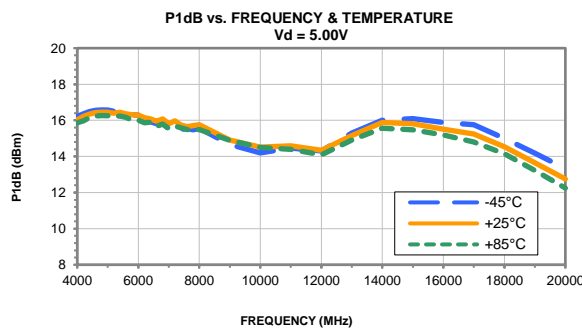
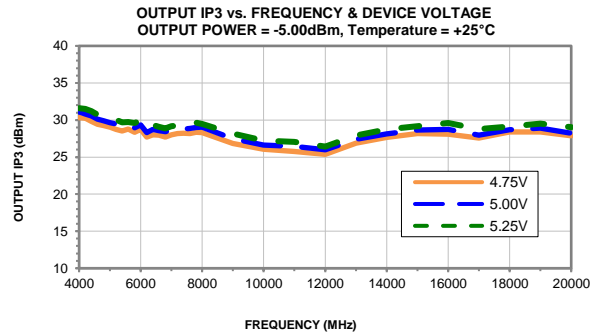
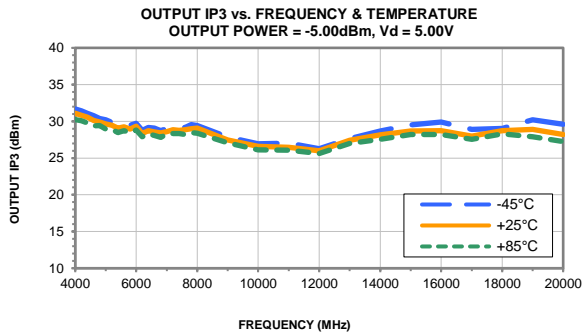

Outline Dimensions

PCB Land Pattern

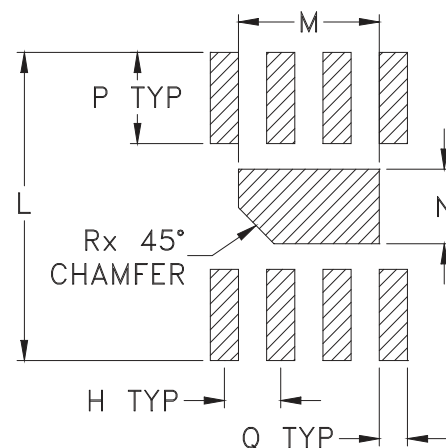
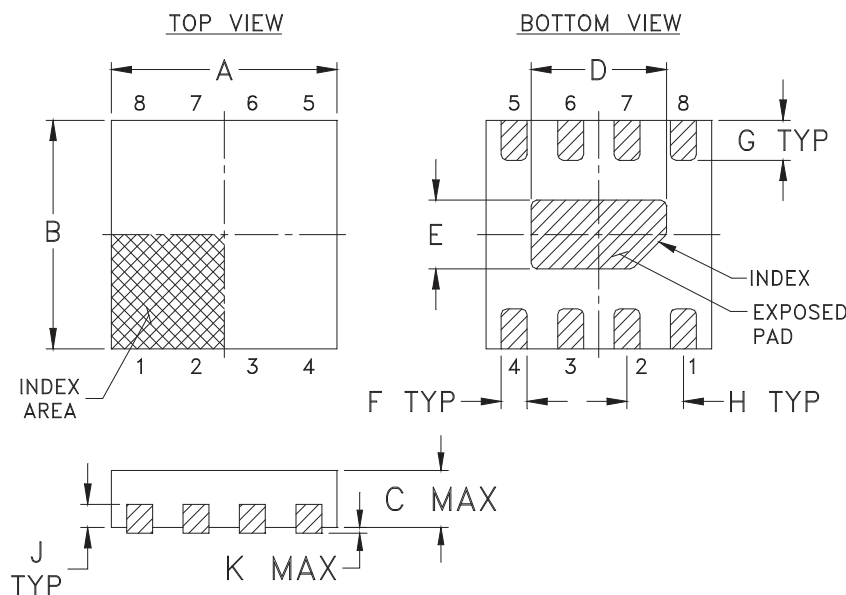

Suggested Layout,
Tolerance to be within $\pm .002$

SE #.	A	B	C	D	E	F	G	H	J	K	L	M	N	P
MC1631-1	.079 (2.00)	.079 (2.00)	.039 (1.00)	.047 (1.20)	.024 (.60)	.009 (.23)	.014 (.35)	.020 (.50)	.008 (.20)	.002 (.05)	.106 (2.70)	.049 (1.25)	.026 (.65)	.031 (.80)

CASE #.	Q	R	WT, GRAM
MC1631-1	.010 (.25)	.012 (.30)	.006

Dimensions are in inches (mm). Tolerances: 2 Pl. $\pm .01$; 3 Pl. $\pm .005$

Notes:

- Case material: Plastic.
- Termination finish:
For RoHS Case Styles: Tin-Silver over Nickel plated or Matte-Tin Plated (See Data sheet).
All models, (+) suffix.
- Lead #1 identifier shall be located in the cross-hatched area shown.
Identifier may be either a molded or marked feature.



P.O. Box 350166, Brooklyn, New York 11235-0003 (718) 934-4500 Fax (718) 332-4661 For detailed performance specs & shopping online see Mini-Circuits web site



The Design Engineers Search Engine Provides ACTUAL Data Instantly From MINI-CIRCUITS At: www.minicircuits.com

RF/IF MICROWAVE COMPONENTS

Tape & Reel Packaging TR-F66



Tape Width, mm	Device Cavity Pitch, mm	Reel Size, inches	Devices per Reel see note	
8	4	7	Small quantity standard	20
				50
				100
				200
				500
		7	Standard	1000, 2000, 3000

Note: Please consult individual model data sheet to determine device per reel availability.

Mini-Circuits carrier tape materials provide protection from ESD (Electro-Static Discharge) during handling and transportation. Tapes are static dissipative and comply with industry standards EIA-481/EIA-541.

Go to: www.minicircuits.com/pages/pdfs/tape.pdf

Mini-Circuits®

INTERNET <http://www.minicircuits.com>

P.O. Box 350166, Brooklyn, New York 11235-0003 (718) 934-4500 Fax (718) 332-4661

Distribution Centers NORTH AMERICA 800-654-7949 • 417-335-5935 • Fax 417-335-5945 • EUROPE 44-1252-832600 • Fax 44-1252-837010

Mini-Circuits ISO 9001 & ISO 14001 Certified

THIRD ANGLE PROJECTION

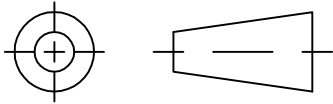

REVISIONS

REV	ECN No.	DESCRIPTION	DATE	DR	AUTH
OR	M175740	NEW RELEASE	08/26/19	ITG	RS
A	ECO-001235	CORRECTED ERRORS	12/30/19	ITG	GH

SUGGESTED MOUNTING CONFIGURATION
FOR MC1631-1 CASE STYLE

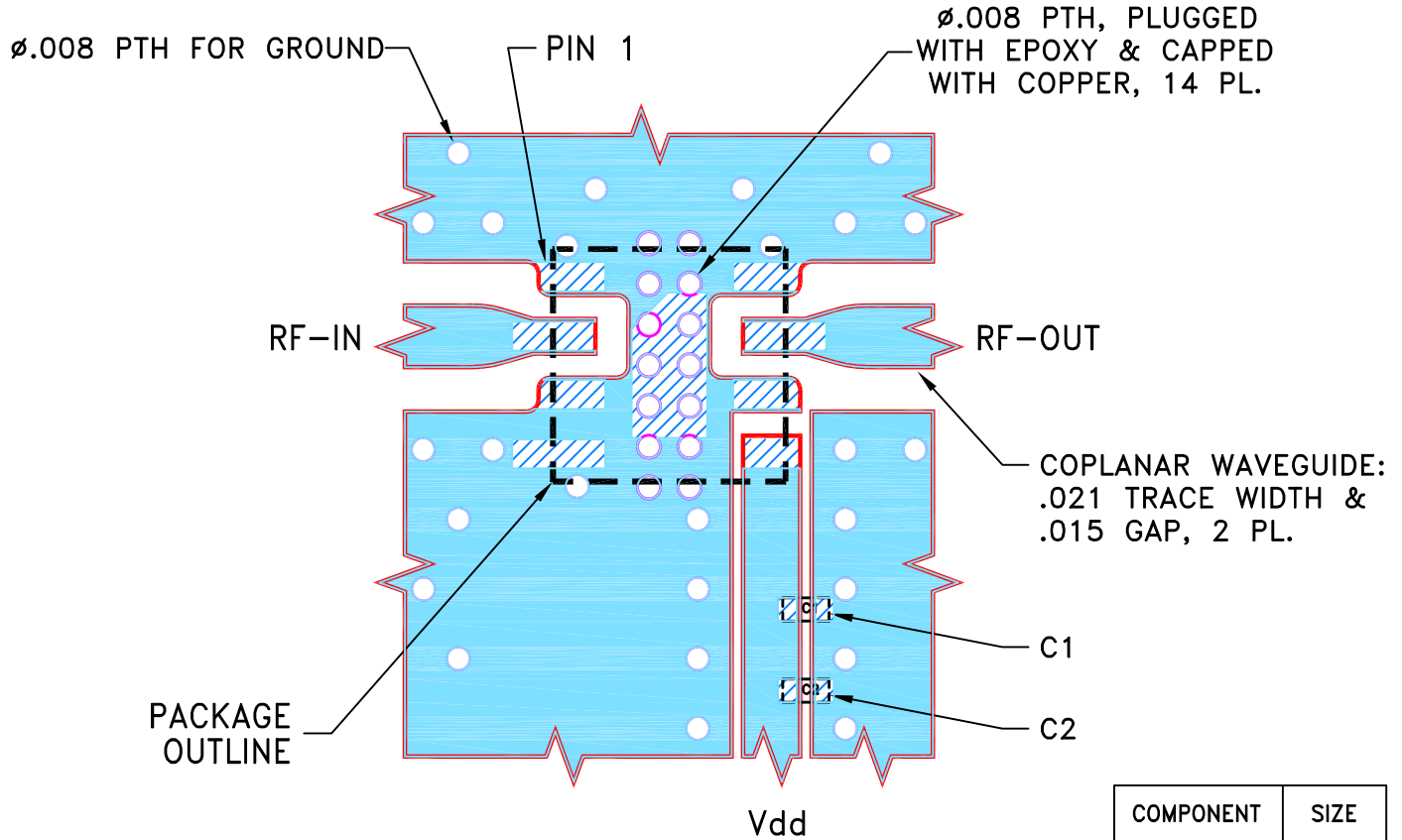

COMPONENT	SIZE
C1,C2	0402

NOTES:

1. TRACE WIDTH & GAP ARE SHOWN FOR ROGERS R04350B WITH DIELECTRIC THICKNESS .010"±.001". COPPER: 1 OZ. EACH SIDE.
FOR OTHER MATERIALS TRACE WIDTH & GAP MAY NEED TO BE MODIFIED.
2. UNIT FOOT PRINT IS OPTIMIZED FOR PERFORMANCE AND IS DIFFERENT FROM CASE STYLE MC1631-1 RECOMMENDATIONS.
3. CHIP COMPONENT FOOT PRINTS SHOWN FOR REFERENCE.
FOR COMPONENT VALUES REFER TO TB-PMA-183LN+.
4. BOTTOM SIDE OF THE PCB IS CONTINUOUS GROUND PLANE.

- DENOTES PCB COPPER LAYOUT WITH SMOBC (SOLDER MASK OVER BARE COPPER).
- DENOTES COPPER LAND PATTERN FREE OF SOLDER MASK.

UNLESS OTHERWISE SPECIFIED	INITIALS	DATE
DIMENSIONS ARE IN INCHES TOLERANCES ON: 2 PL DECIMALS ± 3 PL DECIMALS ± .005 ANGLES ± FRACTIONS ±	DRAWN	ITG 08/16/19
	CHECKED	GF 08/26/19
	APPROVED	RS 08/26/19

Mini-Circuits[®] 13 Neptune Avenue
Brooklyn NY 11235

PL, MC1631-1, TB-PMA2-183LN+

SIZE A	CODE IDENT 15542	DRAWING NO: 98-PL-636	REV: A
FILE: 98PL636	SCALE: 15:1	SHEET: 1 OF 1	

Mini-Circuits[®]
THIS DOCUMENT AND ITS CONTENTS ARE THE PROPERTY OF MINI-CIRCUITS. EXCEPT FOR USE EXPRESSLY GRANTED, IN WRITING, TO ITS VENDORS, VENDEE AND THE UNITED STATES GOVERNMENT, MINI-CIRCUITS RESERVES ALL PROPRIETARY DESIGN, USE, MANUFACTURING AND REPRODUCTION RIGHTS THERETO. THESE CONTENTS SHALL NOT BE USED, DUPLICATED OR DISCLOSED TO ANY OUTSIDE PARTY, IN WHOLE OR IN PART, WITHOUT WRITTEN PERMISSION OF MINI-CIRCUITS.

Evaluation Board and Circuit

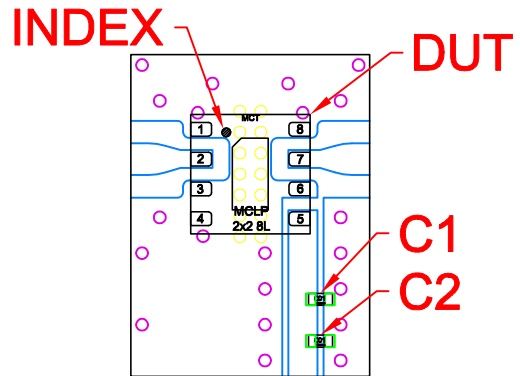
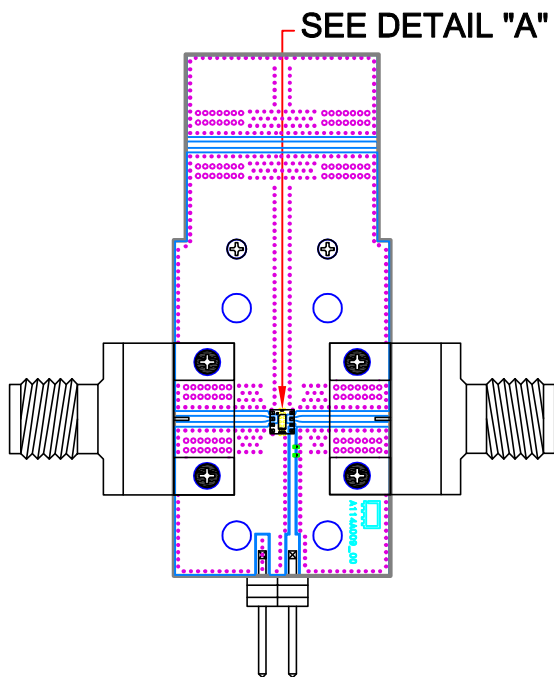

DETAIL "A"
**LOCATION OF INTERCONNECTOR
 AND UNITS COMPONENTS**
 (SCALE 5:1)

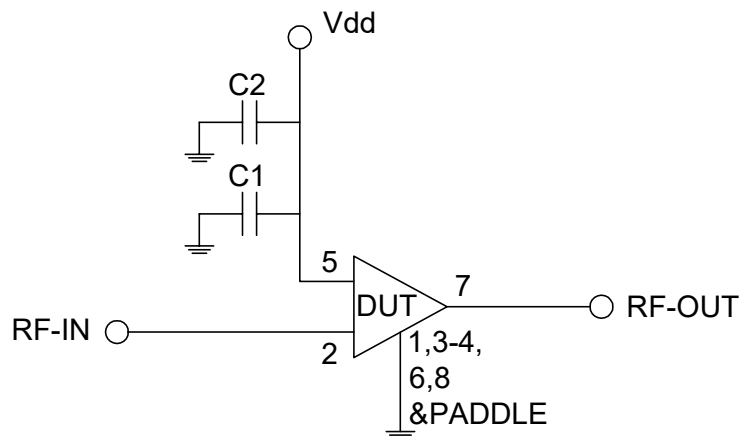

SCHEMATIC DIAGRAM

Component	Size	Value	Part Number	Manufacturer
C1	0402	100pF	GRM1555C1H101JA01J	Murata
C2	0402	0.1uF	GRM155R71C104KA88D	Murata

Notes:

- 2.92mm Female Connectors.
- PCB Material: Roger R04350B or equivalent,
Dielectric constant=3.5, Thickness=0.010 inch

 **Mini-Circuits®**

All Mini-Circuits products are manufactured under exacting quality assurance and control standards, and are capable of meeting published specifications after being subjected to any or all of the following physical and environmental test.

Specification	Test/Inspection Condition	Reference/Spec
Operating Temperature	-40° to 85°C Ambient Environment	Individual Model Data Sheet
Storage Temperature	-55° to 100° C or -65° to 150° Ambient Environment	Individual Model Data Sheet
Thermal Shock	-55° to 100°C, 100 cycles	MIL-STD-202, Method 107, Condition A-3, except +100°C
Mechanical Shock	1.5Kg, 0.5 ms, 5 shock pulses, Y1 direction only	MIL-STD-883, Method 2002, Condition B, except Y1 direction only
Vibration (Variable Frequency)	50g peak	MIL-STD-883, Method 2007, Condition B
Autoclave	15 psig, 100% RH, 121°C, 96 hours	JESD22-A102, Condition C
HAST	130°C, 85% RH, 96 hours	JESD22-A110
Solderability	10X Magnification	J-STD-002, Para 4.2.5, Test S, 95% Coverage
Solder Reflow Heat	Sn-Pb Eutetic Process: 240°C peak Pb-Free Process: 260°C peak	J-STD-020, Table 4-1, 4-2 and 5-2; Figure 5-1
Moisture Sensitivity: Level 1	Bake at 125°C for 24 hours Soak at 85°C/85% RH for 168 hours, Reflow 3 cycles at 260°C peak	J-STD-020
Marking Resistance to Solvents	Isopropyl alcohol + mineral spirits at 25°C; terpene defluxer at 25°C; distilled water + proylene glycol monomethyl ether +	MIL-STD-202, Method 215



All Mini-Circuits products are manufactured under exacting quality assurance and control standards, and are capable of meeting published specifications after being subjected to any or all of the following physical and environmental test.

Specification	Test/Inspection Condition	Reference/Spec
---------------	---------------------------	----------------

monoethanolamine at 63°C to 70°C