

CGHV40030

30 W, DC - 6 GHz, 50 V, GaN HEMT

Description

Cree's CGHV40030 is an unmatched, gallium nitride (GaN) high electron mobility transistor (HEMT) designed specifically for high efficiency, high gain and wide bandwidth capabilities. The device can be deployed for L, S and C-Band amplifier applications. The datasheet specifications are based on a 0.96 - 1.4 GHz amplifier. The CGHV40030 operates on a 50 volt rail circuit while housed in a 2-lead flange or pill package.

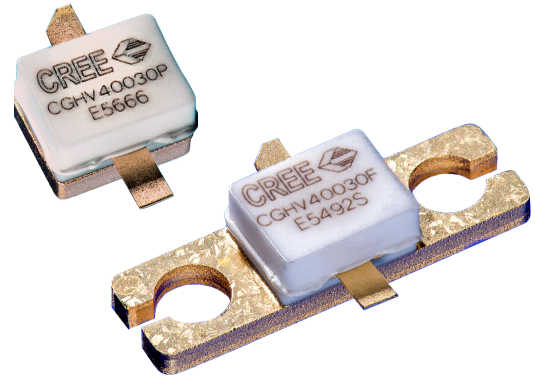

Package Types: 440166 and 440196
PN: CGHV40030

Typical Performance 0.96 - 1.4 GHz ($T_c = 25^\circ\text{C}$), 50 V

Parameter	0.96 GHz	1.1 GHz	1.25 GHz	1.4 GHz	Units
Gain @ P_{SAT}	15.6	15.8	16.6	15.8	dB
Saturated Output Power	29	30	36	31	W
Drain Efficiency @ P_{SAT}	62	74	64	67	%

Note: Measured CW in the CGHV40030-AMP application circuit.

Features

- Up to 6 GHz Operation
- 30 W Typical Output Power
- 16 dB Gain
- Application circuit for 0.96 - 1.4 GHz
- 70% Efficiency at P_{SAT}
- 50 V Operation

Listing of Available Hardware Application Circuits / Demonstration Circuits

Application Circuit	Operating Frequency	Amplifier Class	Operating Voltage
CGHV40030F-AMP	0.96 - 1.4 GHz		50V
CGHV40030F-AMP2	0.5 - 2.7 GHz		50V

 Large Signal Models Available for ADS and MWO

RoHS
COMPLIANT

Absolute Maximum Ratings (not simultaneous) at 25 °C Case Temperature

Parameter	Symbol	Rating	Units	Notes
Drain-Source Voltage	V_{DSS}	150	Volts	25 °C
Gate-to-Source Voltage	V_{GS}	-10, +2	Volts	25 °C
Storage Temperature	T_{STG}	-65, +150	°C	
Operating Junction Temperature	T_J	225	°C	
Maximum Forward Gate Current	I_{GMAX}	5.2	mA	25 °C
Maximum Drain Current ¹	I_{DMAX}	4.2	A	25 °C
Soldering Temperature ²	T_S	245	°C	
Case Operating Temperature ³	T_C	-40, +85	°C	
Thermal Resistance, Junction to Case ⁴	$R_{\theta JC}$	5.9	°C/W	85 °C

Notes:

¹ Current limit for long term, reliable operation² Refer to the Application Note on soldering at wolfspeed.com/RF/Document-Library³ $P_{DISS} = 23.4$ W⁴ CW**Electrical Characteristics ($T_C = 25$ °C)**

Characteristics	Symbol	Min.	Typ.	Max.	Units	Conditions
DC Characteristics¹						
Gate Threshold Voltage	$V_{GS(th)}$	-3.8	-3.0	-2.3	V_{DC}	$V_{DS} = 10$ V, $I_D = 5.2$ mA
Gate Quiescent Voltage	$V_{GS(Q)}$	-	-2.6	-	V_{DC}	$V_{DS} = 50$ V, $I_D = 150$ mA
Saturated Drain Current ²	I_{DS}	3.4	4.8	-	A	$V_{DS} = 6.0$ V, $V_{GS} = 2.0$ V
Drain-Source Breakdown Voltage	$V_{(BR)DSS}$	125	-	-	V_{DC}	$V_{GS} = -8$ V, $I_D = 5.2$ mA
RF Characteristics³ ($T_C = 25$ °C, $F_0 = 1.2$ GHz unless otherwise noted)						
Power Gain ⁴	G_p	15	16	-	dB	$V_{DD} = 50$ V, $I_{DQ} = 150$ mA, $P_{OUT} = P_{SAT}$
Output Power ⁴	P_{OUT}	30	35	-	W	$V_{DD} = 50$ V, $I_{DQ} = 150$ mA, $P_{OUT} = P_{SAT}$
Drain Efficiency ⁴	η	62	65	-	%	$V_{DD} = 50$ V, $I_{DQ} = 150$ mA, $P_{OUT} = P_{SAT}$
Output Mismatch Stress ⁴	VSWR	-	-	10 : 1	Ψ	No damage at all phase angles, $V_{DD} = 50$ V, $I_{DQ} = 150$ mA, $P_{OUT} = 30$ W CW
Dynamic Characteristics						
Input Capacitance ⁵	C_{GS}	-	7.4	-	pF	$V_{DS} = 50$ V, $V_{GS} = -8$ V, $f = 1$ MHz
Output Capacitance ⁵	C_{DS}	-	2	-	pF	$V_{DS} = 50$ V, $V_{GS} = -8$ V, $f = 1$ MHz
Feedback Capacitance	C_{GD}	-	0.15	-	pF	$V_{DS} = 50$ V, $V_{GS} = -8$ V, $f = 1$ MHz

Notes:

¹ Measured on wafer prior to packaging² Scaled from PCM data³ Measured in CGHV40030-AMP⁴ P_{SAT} is defined as $I_G = 0.52$ mA⁵ Includes package



Typical Performance

Figure 1. Typical Small Signal Response of CGHV40030-AMP Application Circuit
 $V_{DD} = 50\text{ V}, I_{DQ} = 150\text{ mA}$

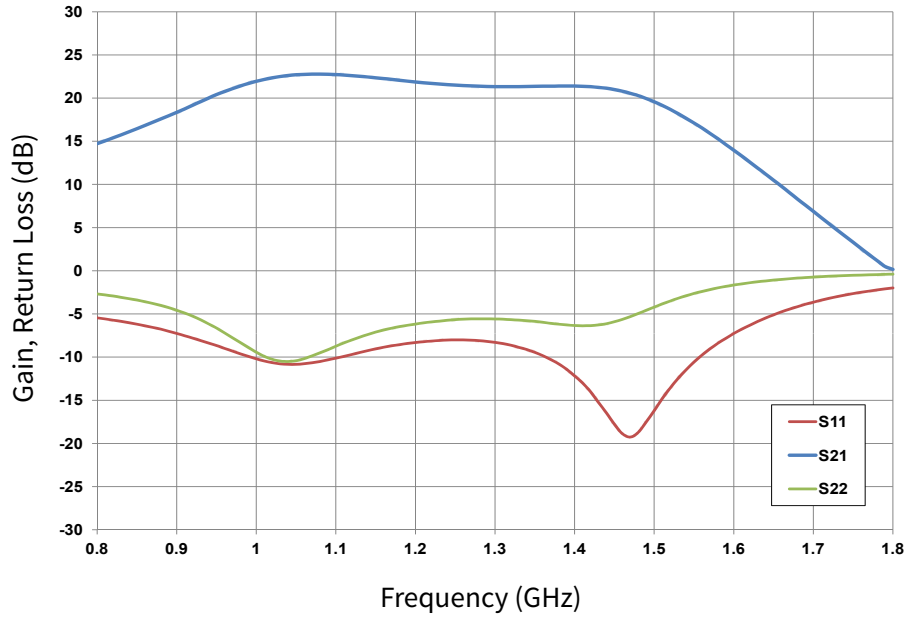
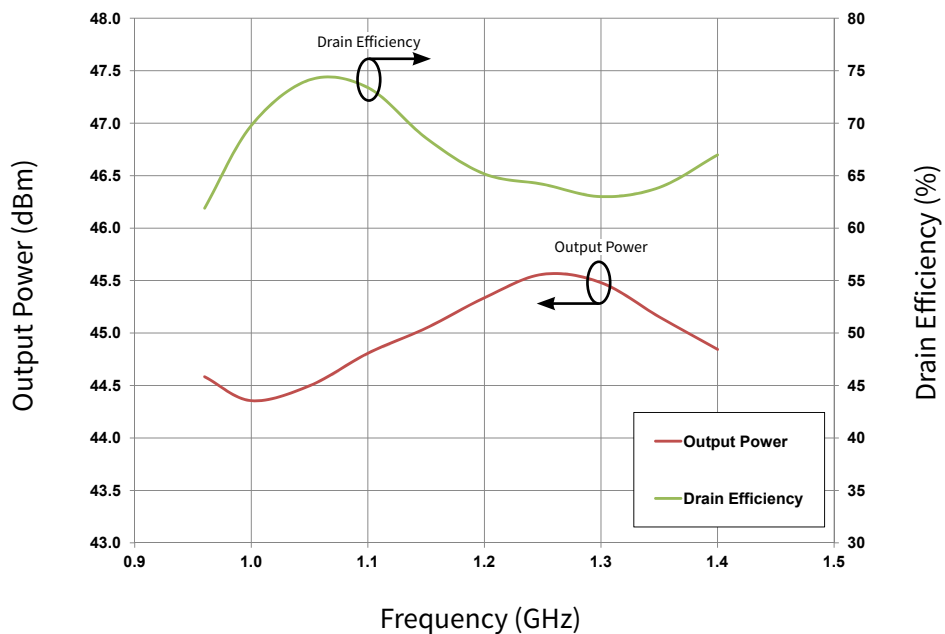

Figure 2. Typical Large Signal Response of CGHV40030-AMP Application Circuit
 $V_{DD} = 50\text{ V}, I_{DQ} = 150\text{ mA}, P_{IN} = 29\text{ dBm}, T_{CASE} = 25^\circ\text{C}, \text{CW}$



CGHV40030-AMP Application Circuit Bill of Materials

Designator	Description	Qty
R1	RES,1/16W,0603,1%,187 OHMS	1
R2	RES, 2.2 OHMS, +/- 1%, 1/16W,0603	1
R3	RES,1/16W,0603,1%,15.4 OHMS	1
L1	IND, 5.6nH, 0603	1
C3, C4	CAP, 2.7,+/-0.1pF, 0603, ATC	2
C11, C12	CAP, 1.2pF,+/-0.1pF, 0603, ATC	2
C5, C6	CAP, 0.8pF,+/-0.1pF, 0603, ATC	2
C2, C7, C8	CAP 1.8pF,+/-0.05pF 0603, ATC	3
C9, C10	CAP, 3.9pF,+/-0.1pF 0603, ATC	2
C1, C13	CAP, 24pF,+/-5% 0603, ATC	2
C14	CAP 10UF 16V TANTALUM	1
C15, C20	CAP, 33000pF, 0805, ATC	2
C16,C21	CAP, 470PF, 5%, 100V, 0603,	2
C17	CAP, 68pF,+/-0.1pF 0603, ATC	1
C22	CAP, 56PF +/- 5%, 0603 , ATC600S	1
C18	CAP, 33UF, 20%, G CASE	1
C19	CAP, 1.0UF, 100V, 10%, X7R, 1210	1
J1,J2	CONN, SMA, PANEL MOUNT JACK, FLANGE, 4-HOLE, BLUNT POST	2
J3	HEADER RT>PLZ .1CEN LK 5POS	1
-	BASEPLATE, CGH35015, 2.60 X 1.7	1
-	CGHV40030F/P PCB, RO4350, 0.020" THK	1
-	2-56 SOC HD SCREW 1/4 SS	4
-	#2 SPLIT LOCKWASHER SS	4

CGHV40030-AMP Application Circuit

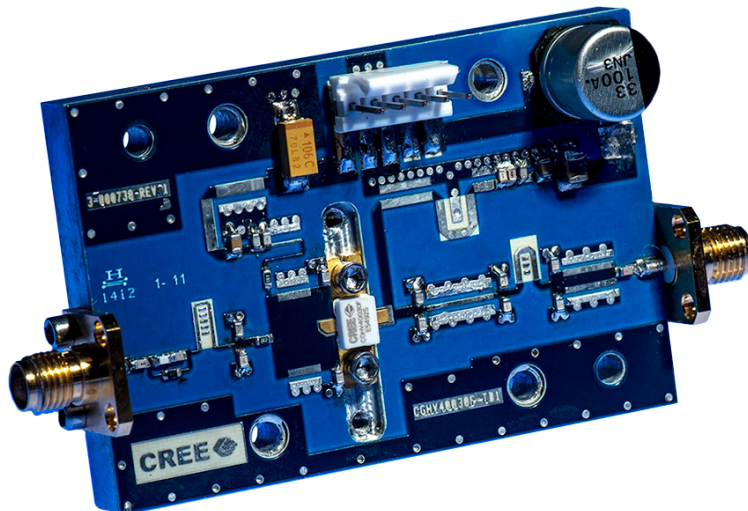



CGHV40030-AMP Application Circuit Schematic

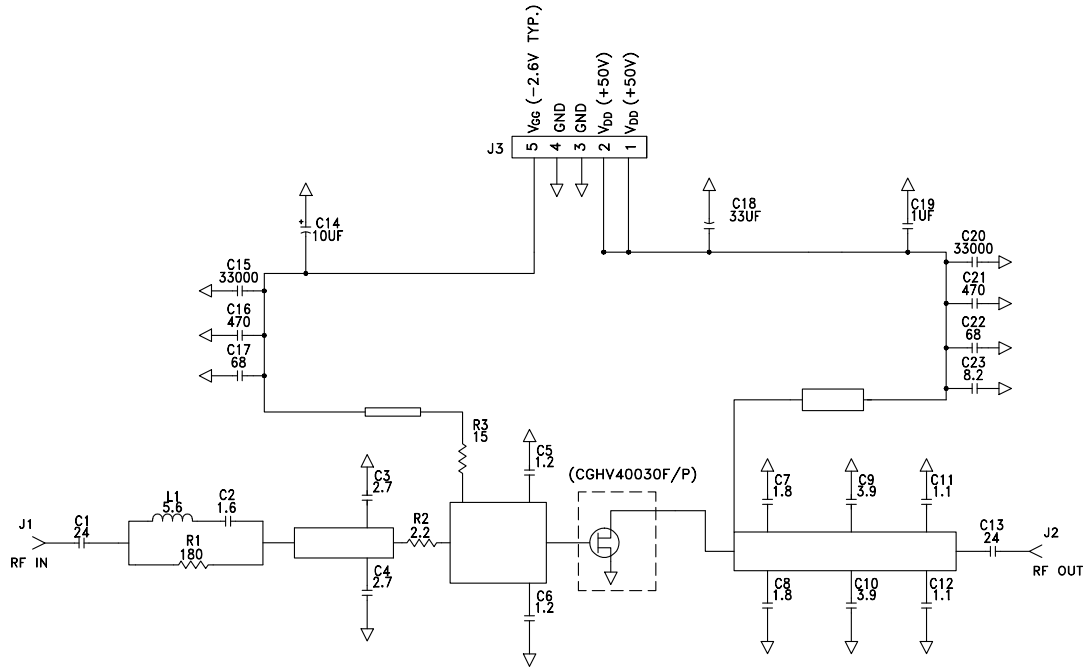

CGHV40030-AMP Application Circuit Outline

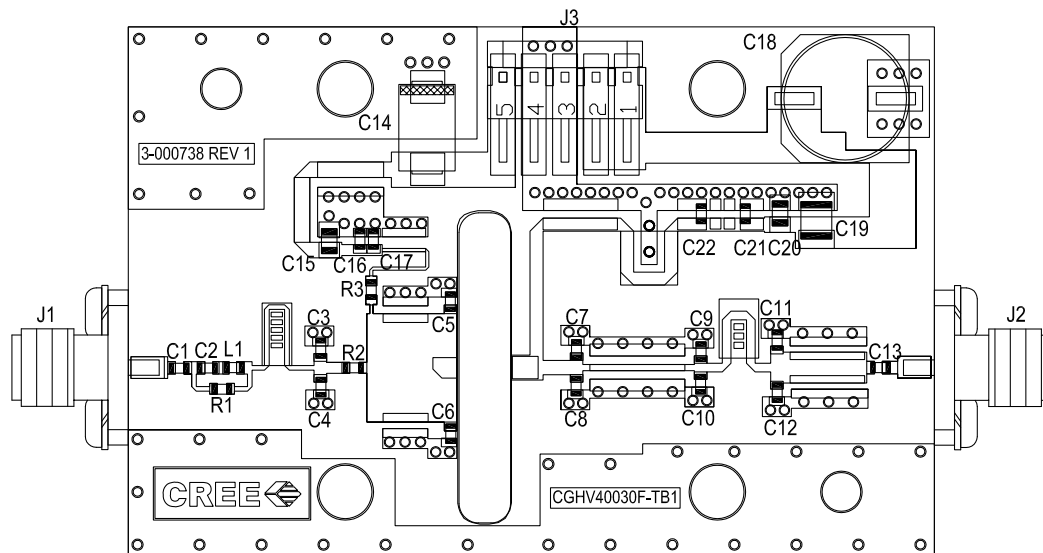



Source and Load Impedances for Application Circuit CGHV40030-AMP

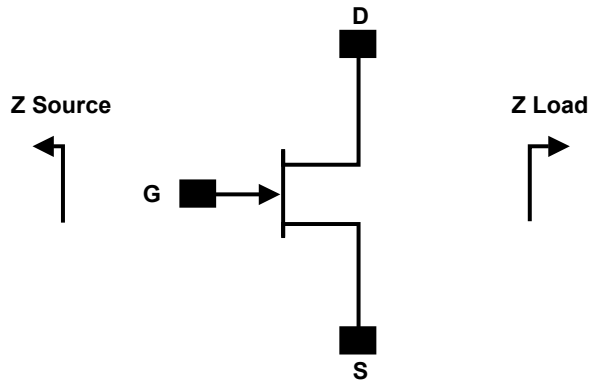

Frequency	Z Source	Z Load
500	5.5 + j0.9	43 + j20.8
1000	2.6 - j1.3	25.5 + j29.1
2000	3.8 - j0.9	11.5 + j17.3
3000	2.7 - j7.0	6.7 + j7.8
4000	2.8 - j13.4	6.5 + j1.7

Note 1. $V_{DD} = V_{DD} = 50\text{ V}$, $I_{DQ} = 150\text{ mA}$

Note 2. Impedances are extracted from source and load pull data derived from the transistor.

Electrostatic Discharge (ESD) Classifications

Parameter	Symbol	Class	Test Methodology
Human Body Model	HBM	1A (> 250 V)	JEDEC JESD22 A114-D
Charge Device Model	CDM	II (200 < 500 V)	JEDEC JESD22 C101-C



Electrical Characteristics When Tested in CGHV40030-AMP2, 50 V, 0.5 - 2.7 GHz

Parameter ^{1,2,3}	0.5 GHz	1.1 GHz	2.7 GHz	Units
Gain	13.7	15.0	12.5	dB
Output Power	29.8	40.0	22.8	W
Drain Efficiency	62.0	58.7	48.6	%

Notes:

¹ Measured CW in the CGHV40030F-AMP2 application circuit

² P_{IN} = 31 dBm

³ Typical performance values

CGHV40030F-AMP2 Typical Performance

Figure 1. Typical Small Signal Response of CGHV40030F-AMP2
 $V_{DD} = 50\text{ V}, I_{DQ} = 90\text{ mA}$

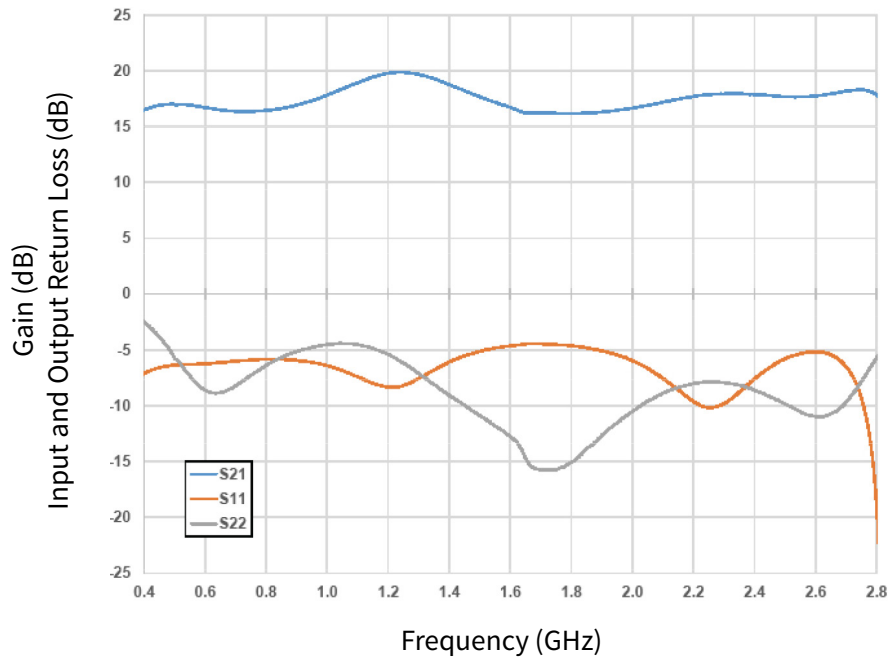
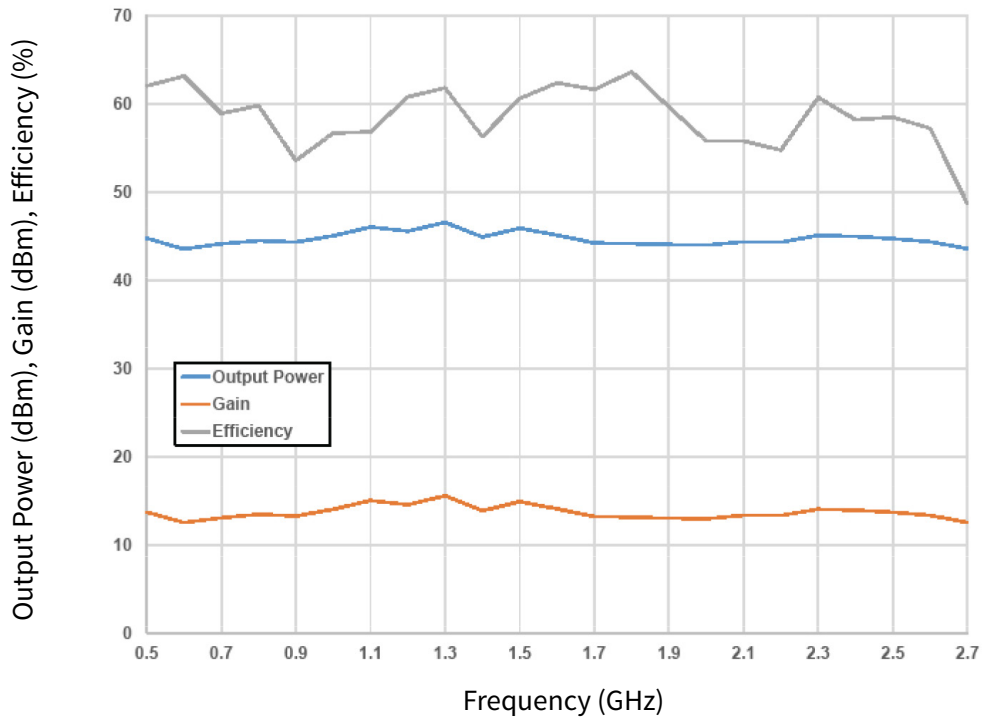
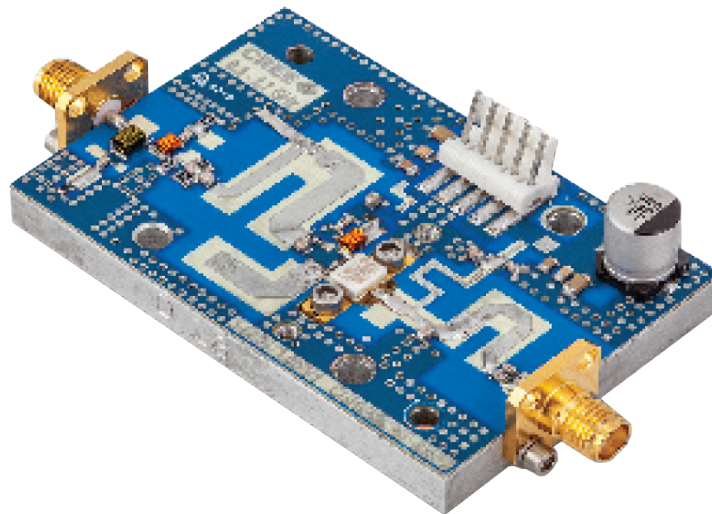



Figure 2. Typical Large Signal Response of CGHV40030F-AMP2 Application Circuit
 $V_{DD} = 50\text{ V}$, $I_{DQ} = 90\text{ mA}$, $P_{IN} = 31\text{ dBm}$



CGHV40030F-AMP2 Application Circuit



CGHV40030F-AMP2

Designator	Description	Qty
R4	RES,0.25W,0603,1%,5.6 OHMS	1
R7	RES,0.25W,0603,1%,10 OHMS	1
R3,6	RES,0.5W,0805, 1% 43 OHMS	2
R1	RES,0.25W,0603, 5%,100 OHMS	1
R2	RES,0.5W,0805, 1% 100 OHMS	1
R5	RES,0.5W,0805, 1% 390 OHMS	1
C13	CAP, 1.5pF, +/-0.1pF, 0505C, 150V, PPI	1
C3	CAP, 3.6pF, +/-0.1pF, 0505C, 150V, PPI	1
C11 (on side)	CAP, 120pF, +/-5%, 0805, 250V, ATC	1
C4, 5	CAP, 30pF, +/-2%, 0505C, 150V, PPI	2
C1,2,7,12,14,15	CAP, 100pF, +/-5%, 0603, 250V, ATC	6
C6	CAP, 470pF, +/-5%, 0505C, 150V, PPI	1
C8,16	CAP,1NF, 0805,100V, X7R	2
C9,17	CAP,10NF, 0805,100V, X7R	2
C18	CAP,100NF, 0805,100V, X7R	1
C10	CAP, 10UF, 10%, 1206,16V, X5R	1
C19	CAP, 33UF, 20%, F CASE, 63V	1
L2	IND, 21.5nH, 2% Air Core, Coilcraft	1
L3	IND, 25nH, 2% Air Core, Coilcraft	1
L1	IND, 47nH, 5% Air Core, Coilcraft	1
J2,J3	CONN, SMA, PANEL MOUNT JACK, FLANGE, 4-HOLE, BLUNT POST	2
-	PCB, Rogers RO4350B1 20mils 2oz. Cu 66x44mm	1
-	BASEPLATE, 2.60 X 1.70 X .25" modified	1
J1	HEADER RT>PLZ .1CEN LK 5POS	1
-	2-56 SOC HD SCREW 1/4 SS	2
-	#2 SPLIT LOCKWASHER SS	2
-	Lead Clamp 440166	1
Q1	Transistor CGHV40030F	1

CGHV40030F-AMP2 Application Circuit Schematic

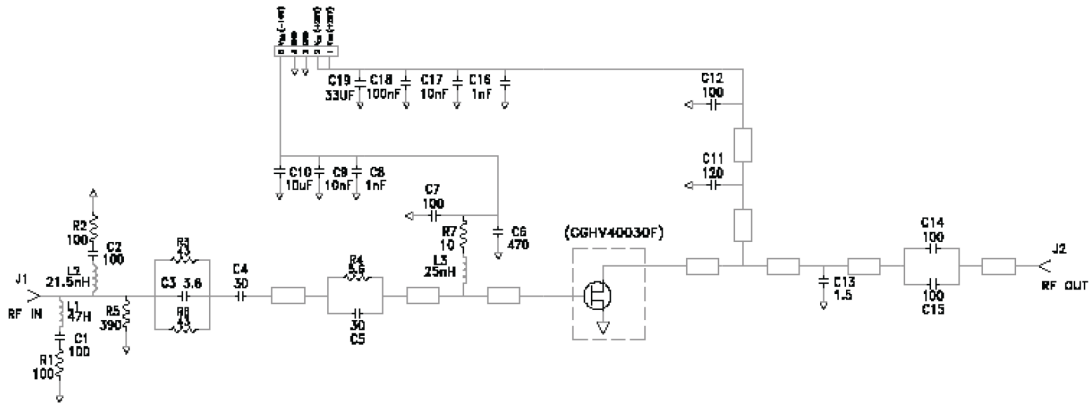

CGHV40030F-AMP2 Application Circuit Outline

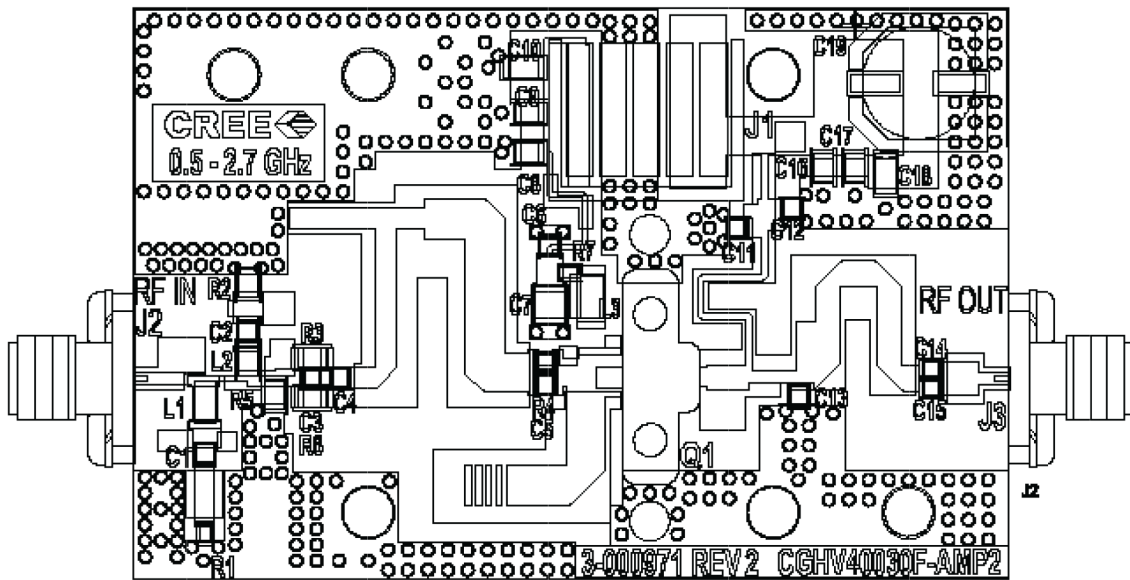

Typical Package S-Parameters for CGHV40030
(Small Signal, $V_{DS} = 50$ V, $I_{DQ} = 150$ mA, angle in degrees)

Frequency	Mag S11	Ang S11	Mag S21	Ang S21	Mag S12	Ang S12	Mag S22	Ang S22
500 MHz	0.92	-135.45	21.23	101.31	0.01	16.50	0.32	-74.10
600 MHz	0.92	-143.51	18.06	95.44	0.01	11.72	0.32	-79.66
700 MHz	0.91	-149.71	15.66	90.50	0.01	7.89	0.31	-84.44
800 MHz	0.91	-154.67	13.78	86.16	0.01	4.69	0.32	-88.69
900 MHz	0.91	-158.75	12.27	82.26	0.01	1.97	0.33	-92.58
1.0 GHz	0.91	-162.21	11.04	78.67	0.01	-0.41	0.34	-96.19
1.1 GHz	0.91	-165.20	10.02	75.32	0.01	-2.50	0.35	-99.57
1.2 GHz	0.91	-167.83	9.15	72.16	0.01	-4.34	0.36	-102.79
1.3 GHz	0.91	-170.19	8.41	69.14	0.01	-5.98	0.37	-105.86
1.4 GHz	0.92	-172.34	7.76	66.24	0.01	-7.43	0.39	-108.80
1.5 GHz	0.92	-174.30	7.20	63.45	0.01	-8.69	0.40	-111.64
1.6 GHz	0.92	-176.13	6.70	60.74	0.01	-9.77	0.42	-114.39
1.7 GHz	0.92	-177.83	6.26	58.11	0.01	-10.67	0.43	-117.06
1.8 GHz	0.92	-179.44	5.86	55.54	0.01	-11.39	0.45	-119.65
1.9 GHz	0.92	179.04	5.50	53.03	0.01	-11.90	0.46	-122.18
2.0 GHz	0.92	177.58	5.18	50.58	0.01	-12.20	0.48	-124.64
2.1 GHz	0.92	176.19	4.89	48.17	0.01	-12.26	0.49	-127.05
2.2 GHz	0.92	174.84	4.62	45.81	0.01	-12.07	0.51	-129.41
2.3 GHz	0.93	173.54	4.37	43.50	0.01	-11.60	0.52	-131.72
2.4 GHz	0.93	172.28	4.14	41.22	0.01	-10.82	0.53	-133.98
2.5 GHz	0.93	171.06	3.93	38.98	0.01	-9.70	0.55	-136.21
2.6 GHz	0.93	169.86	3.73	36.78	0.01	-8.20	0.56	-138.39
2.7 GHz	0.93	168.70	3.55	34.62	0.01	-6.30	0.57	-140.53
2.8 GHz	0.93	167.55	3.38	32.49	0.01	-3.97	0.59	-142.63
2.9 GHz	0.93	166.43	3.23	30.39	0.01	-1.18	0.60	-144.70
3.0 GHz	0.94	165.33	3.08	28.33	0.01	2.04	0.61	-146.73
3.2 GHz	0.94	163.18	2.81	24.29	0.01	9.69	0.64	-150.70
3.4 GHz	0.94	161.08	2.57	20.36	0.01	18.36	0.66	-154.54
3.6 GHz	0.94	159.05	2.36	16.55	0.01	27.05	0.68	-158.26
3.8 GHz	0.95	157.05	2.17	12.85	0.01	34.79	0.70	-161.87
4.0 GHz	0.95	155.10	2.00	9.25	0.01	41.04	0.72	-165.37
4.2 GHz	0.95	153.19	1.85	5.75	0.01	45.73	0.73	-168.77
4.4 GHz	0.95	151.31	1.72	2.35	0.01	49.02	0.75	-172.07
4.6 GHz	0.96	149.46	1.59	-0.96	0.01	51.19	0.76	-175.28
4.8 GHz	0.96	147.65	1.48	-4.18	0.01	52.48	0.78	-178.39
5.0 GHz	0.96	145.86	1.37	-7.31	0.01	53.11	0.79	178.58
5.2 GHz	0.96	144.11	1.28	-10.36	0.01	53.24	0.80	175.63
5.4 GHz	0.96	142.38	1.19	-13.33	0.01	52.98	0.82	172.76
5.6 GHz	0.96	140.68	1.11	-16.22	0.02	52.43	0.83	169.97
5.8 GHz	0.97	139.00	1.04	-19.03	0.02	51.65	0.84	167.25
6.0 GHz	0.97	137.35	0.98	-21.76	0.02	50.70	0.85	164.60

To download the s-parameters in s2p format, go to the [CGHV40030](#) Product page and click on the documentation tab.

Product Dimensions CGHV40030F (Package Type - 440166)

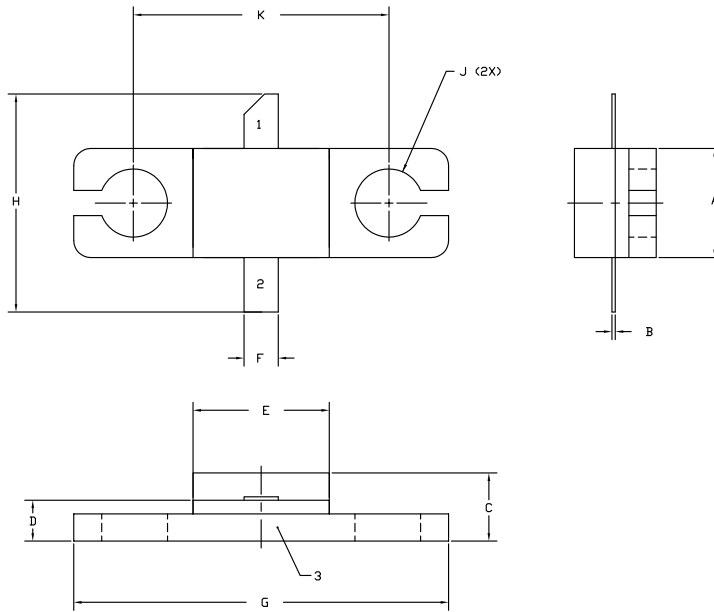

- NOTES:
1. DIMENSIONING AND TOLERANCING PER ANSI Y14.5M, 1982.
 2. CONTROLLING DIMENSION: INCH.
 3. ADHESIVE FROM LID MAY EXTEND A MAXIMUM OF 0.020" BEYOND EDGE OF LID.
 4. LID MAY BE MISALIGNED TO THE BODY OF THE PACKAGE BY A MAXIMUM OF 0.008" IN ANY DIRECTION.
 5. ALL PLATED SURFACES ARE NI/AU

DIM	INCHES		MILLIMETERS	
	MIN	MAX	MIN	MAX
A	0.155	0.165	3.94	4.19
B	0.004	0.006	0.10	0.15
C	0.115	0.135	2.92	3.43
D	0.057	0.067	1.45	1.70
E	0.195	0.205	4.95	5.21
F	0.045	0.055	1.14	1.40
G	0.545	0.555	13.84	14.09
H	0.280	0.360	7.11	9.14
J	Ø .100		2.54	
K	0.375		9.53	

- PIN 1. GATE
 PIN 2. DRAIN
 PIN 3. SOURCE

Product Dimensions CGHV40030P (Package Type - 440196)

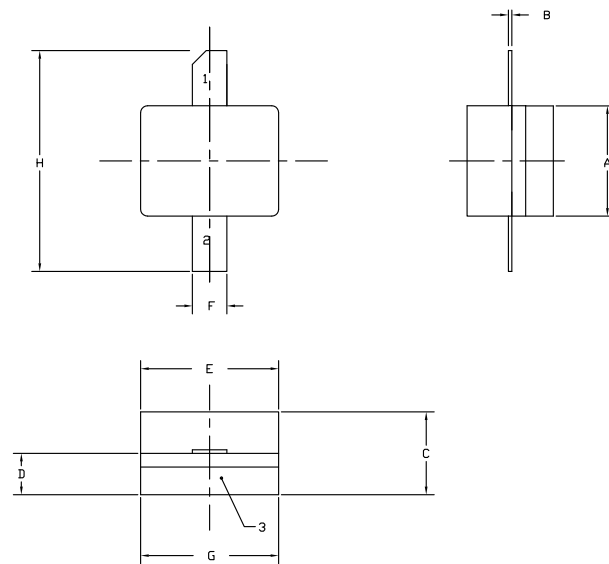

- NOTES:
1. DIMENSIONING AND TOLERANCING PER ANSI Y14.5M, 1982.
 2. CONTROLLING DIMENSION: INCH.
 3. ADHESIVE FROM LID MAY EXTEND A MAXIMUM OF 0.020" BEYOND EDGE OF LID.
 4. LID MAY BE MISALIGNED TO THE BODY OF THE PACKAGE BY A MAXIMUM OF 0.008" IN ANY DIRECTION.
 5. ALL PLATED SURFACES ARE NI/AU

DIM	INCHES		MILLIMETERS	
	MIN	MAX	MIN	MAX
A	0.155	0.165	3.94	4.19
B	0.003	0.006	0.10	0.15
C	0.115	0.135	2.92	3.17
D	0.057	0.067	1.45	1.70
E	0.195	0.205	4.95	5.21
F	0.045	0.055	1.14	1.40
G	0.195	0.205	4.95	5.21
H	0.280	0.360	7.11	9.14

- PIN 1. GATE
 PIN 2. DRAIN
 PIN 3. SOURCE

Part Number System

CGHV40030F/P



Table 1.

Parameter	Value	Units
Upper Frequency ¹	6	GHz
Power Output	30	W
Package	Flanged/Pill	-



Note¹: Alpha characters used in frequency code indicate a value greater than 9.9 GHz. See Table 2 for value.

Table 2.

Character Code	Code Value
A	0
B	1
C	2
D	3
E	4
F	5
G	6
H	7
J	8
K	9
Examples:	1A = 10.0 GHz 2H = 27.0 GHz

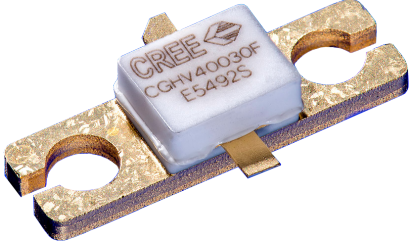

Product Ordering Information

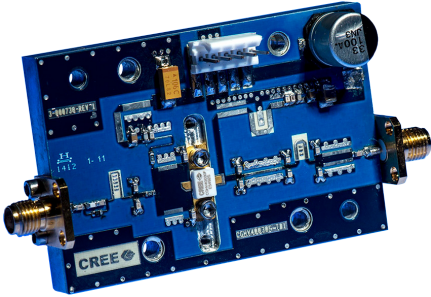
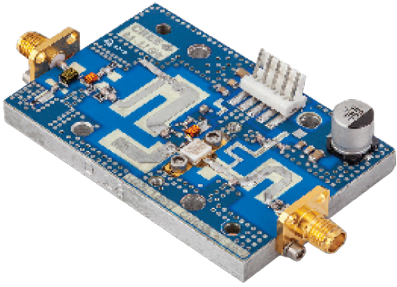
Order Number	Description	Unit of Measure	Image
CGHV40030F	GaN HEMT	Each	
CGHV40030P	GaN HEMT	Each	
CGHV40030F-AMP	Test board with GaN HEMT installed	Each	
CGHV40030F-AMP2	Test board with GaN HEMT installed	Each	



For more information, please contact:

4600 Silicon Drive
Durham, North Carolina, USA 27703
www.wolfspeed.com/RF

Sales Contact
RFSales@cree.com

Notes

Disclaimer

Specifications are subject to change without notice. “Typical” parameters are the average values expected by Cree in large quantities and are provided for information purposes only. Cree products are not warranted or authorized for use as critical components in medical, life-saving, or life-sustaining applications, or other applications where a failure would reasonably be expected to cause severe personal injury or death. No responsibility is assumed by Cree for any infringement of patents or other rights of third parties which may result from use of the information contained herein. No license is granted by implication or otherwise under any patent or patent rights of Cree.